

DESIGN NO. NORDIC/RCA 60-01  
 ASSEMBLY RATING: 60 MINUTES  
 ROOF/CEILING ASSEMBLY

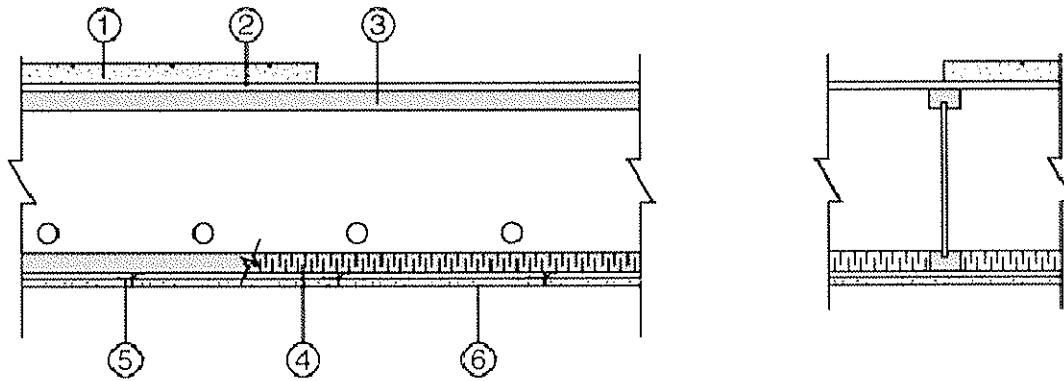

1.	<b>Roof Covering System:</b> Insulation and roof covering materials intended for built-up covering which provides Class A, B, or C covering on combustible wood decks for fire resistant assemblies equivalent to this assembly.
2.	<b>Sheathing:</b> Minimum 1/2 in. square edge plywood or oriented strandboard (OSB). Sheathing installed perpendicular to joists, with end joints staggered, fastened in accordance with Code requirements.
3.	<b>Structural Members:</b> Nordic I-joist, Minimum joist depth 9-1/4 in., minimum flange dimension 1-1/2 in. by 3-1/2 in., installed at 24 in. on centers maximum.
4.	<b>Insulation:</b> 1-1/2 in. rock wool insulation, nominal 2.5 pcf density, friction fit between flanges.
5.	<b>Resilient Channels:</b> Nominal 24 gauge galvanized steel channels installed perpendicular to joists and spaced 16 in. on centers maximum. Additional channels required at gypsum wallboard end joints such that each board end rests on its own channel. These additional channels shall extend to the next joist on each side of the board edges. Channels fastened with 1-5/8 in. long Type W screws at each joist intersection.
6.	<b>Gypsum Board:</b> One layer of 5/8 in. Type C gypsum wallboard installed perpendicular to channels with end joints staggered 48 in. Boards to be fastened to channels with minimum 1-1/8 in. Type S screws located 7 in. on center. Screws shall be minimum 1-1/2 in. from board edges and 3/4 in. from board ends. Gypsum wallboard shall be taped and filled. Screw heads shall be filled with gypsum joint compound.