

Design No. CC / BA 120-01 LOADED RESTRAINED BEAM
Carboline Company (Formerly Nu-Chem, Inc.) Fire-Sorb 1001 ASTM E119-98 Assembly Rating – 2 hr.

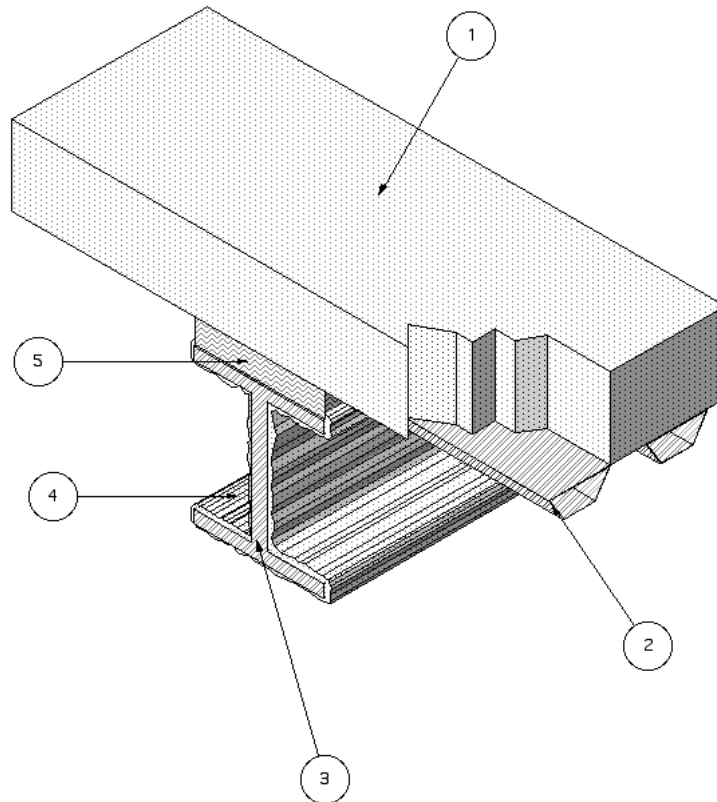

1. CONCRETE FLOOR ASSEMBLY: Normal or lightweight concrete (min. 105 pcf) with a min. 4-1/2 inch coverage.
2. FLUTED STEEL FLOOR UNITS: Corrugated steel decking, min. 1-1/2 in. deep, min. 20 GA.
3. STEEL STRUCTURAL BEAM: W6x25 steel beam, min. size, with an applied load, which stressed the beam to 22.0 ksi..
4. FIRE-RESISTIVE COATING: The steel beam is grit blasted and primed with a two component epoxy primer to a nom. dry film thickness of 0.002 in. The Fire-

Sorb 1001 is applied to all exposed surfaces by spraying or painting in multiple coats to a final dry film thickness of 2.8 mm (0.110 in.).

Listed Manufacturer:

Carboline Company –
High-Performance Coatings
High-Performance Coating Systems
Fire-Sorb 1001

5. FLUTE FILLER: Completely fill the flutes between beam and the fluted steel floor units with 4 pcf mineral wool or 4 pcf ceramic fiber blanket.

Listed Manufacturer:

Only Intertek Certified Mineral Wool and Ceramic Fiber Blanket Manufacturer's products meeting the above minimum requirements.

6. RESTRAINED ASSEMBLY RATINGS:
The beam system is qualified for use in

constructions with 2 hour Restrained Assembly Ratings with the limitation that the beam topping (floor or roof assembly) must have equivalent or greater heat sink properties to that of a corrugated steel deck with lightweight concrete topping.