

Jeremias Inc.
Design No. JER/FMF 120-01
Fire Resistant Grease Duct
Model DWGD-RZ Grease Duct
UL 2221

Internal Fire Test, Condition A – Pass
Fire Engulfment Test – 2 Hours

UL 1978 – Pass

ASTM E814

F-Rating – 2 Hours

T-Rating – 2 Hours

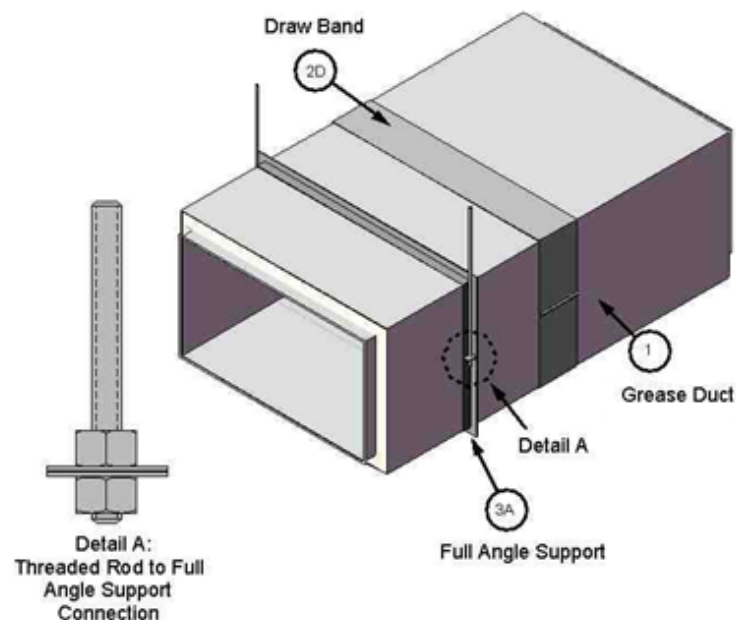

Figure 1. Model DWGD-RZ Grease Duct

1. CERTIFIED MANUFACTURER: Jeremias Inc.

CERTIFIED PRODUCT: Pre-Fabricated Grease Duct

CERTIFIED MODEL: DWGD-RZ

Reference Figure 1. Install Pre-Fabricated Grease Duct in compliance with the requirements of NFPA 96, the International Mechanical Code (IMC), or other regulatory

requirement, as applicable. Install at a slope not less than 1/4 unit vertical in 12 units horizontal toward the hood or toward a grease reservoir. Where horizontal ducts exceed 75 ft. in length, the slope shall be not less than one unit vertical in 12 units horizontal. Alternatively, install at a slope not less than 1/8 unit vertical in 12 units horizontal toward the hood or toward a grease reservoir; where horizontal ducts exceed 75 ft. in length, the slope shall not be



less than 1/2 unit vertical in 12 units horizontal. Obtain AHJ approval for this alternate method. Use the Intertek-certified Pre-Fabricated Grease Duct identified above and having the following features and/or specifications:

- A. GREASE DUCT SIZE –
 - Max. Interior Cross-Section Area: 1,296 in²
 - Max. Interior Dimension: 48 in.
 - Min. Interior Dimension: 4 in.
 - Max. Interior Width to Height Ratio: 6:1
- B. INNER LINER – Min. 20 GA stainless steel
- C. OUTER SHELL – Min. 24 GA aluminized steel, galvanized steel, or stainless steel for ducts with outside dimensions less than or equal to 36 in., and min. 20 GA

aluminized steel, galvanized steel, or stainless steel for ducts with outside dimensions greater than 36 in.

- D. ACCESS DOOR – Reference Figure 2. When required, use a Pre-Fabricated Grease Duct section pre-equipped by manufacturer with an access door assembly having a max. 20 in. x 20 in. opening at the inner access panel and three layers of nominal 1 in. thick insulation, or two layers of nominal 1-1/2 in. thick insulation of the same type and density as the insulation used in the annular space of the duct. In lieu of the manufactured inner access door, a Ductmate F2 access door having a max. 24 in. x 18 in. opening at the access panel may be installed according to the manufacturer's installation instructions.

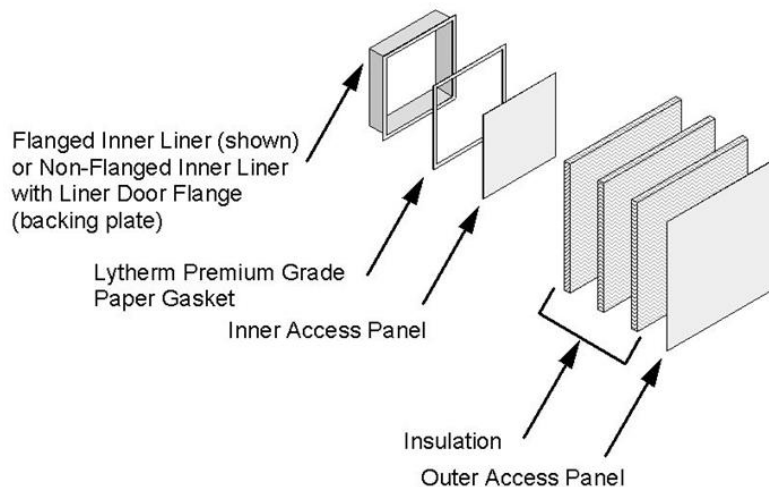

Figure 2. Access Door

- E. PIPE FITTINGS – When required, use Pre-Fabricated Grease Duct sections pre-equipped with pipe fittings including those used for fire extinguishing systems, drain systems, and test ports.

Maintain min. code required clearance to combustibles or limited combustibles at pipe fitting locations.



2. JOINTS: Join the Pre-Fabricated Grease Duct (Item 1) sections using the following components and methods:

- A. **JOINT SEALANT** – Apply a continuous 1/8 in. bead of Accumetric, LLC, Boss® 315 Clear, RTV 100% Professional Grade Sealant to each of the inner liner mating flanges. Ensure that the liner flanges are clean and degreased.
- B. **FASTENERS** – Butt the flanged ends and fasten with supplied 1/4-20 nuts and bolts, tightened to a torque of approximately 4 ft-lb, and per bolt manufacturer's recommended specifications. Remove excess sealant on the inside of the duct and allow sealant to cure 7 days before use.
- C. **JOINT INSULATION** – Use the supplied nominal 6 in. wide, and nominal 1 in. thick or nominal 1-1/2 in. thick, joint insulation strip of the same type and density as the insulation used in the annular space of the Pre-Fabricated Grease Duct (Item 1). Wrap the insulation strip around the connection three times or two times, respectively, depending on the nominal thickness, to

create a 3 in. thickness of insulation; add a min. 2 in. overlap at the final turn. Ensure the joint insulation completely fills and is compressed into the un-insulated void at the joint.

- D. **DRAW BAND** – Use the supplied Draw Band (single band or two half-bands) to cover the Joint Insulation (Item 2C). Fasten the Draw Band using supplied 1/4-20 Philips pan-head screw and square nuts. On vertical lengths of duct, also use No. 6, 1/4 in. long, Philips head, sheet metal screws to secure the draw band to the outer shell at the midpoints of each side, top, and bottom.
- E. **PLATE SUPPORT ASSEMBLY (PLS)** – When required for structural support applications, install the supplied PLS steel plate between the two joint flanges. Follow all other standard joint requirements, except that the joint insulation (Item 2C) is half the width and installed from both sides of the PLS. Use draw bands (Item 2D) on both sides of the PLS. Maintain min. code required clearance to combustibles or limited combustibles at PLS locations.

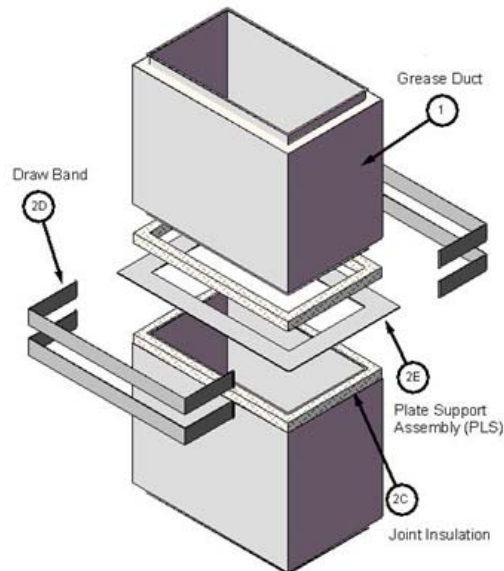

Figure 3. Plate Support Assembly (PLS)

3. SUPPORTS: Rigidly support the Pre-Fabricated Grease Duct (Item 1) as specified below or in accordance with IMC, NFPA 96, or other regulatory requirements as applicable, when those requirements are greater or not covered herein. Follow the requirements for horizontal and vertical supports in Items 3A, 3B, and 3C below.

A. **HORIZONTAL SUPPORTS** – Support the Pre-Fabricated Grease Duct (Item 1) using supplied 2 in. x 2 in. x 3/16 in. steel, full-angle supports (See Figure 1) (two halves required); 2 in. x 2 in. x 3/16 in. steel angle trapeze style support; or P1000 steel Unistrut® trapeze style support with open side facing away from the duct. For the steel angle and Unistrut® options, extend these supports a min. of 2 in. from each side of the Pre-Fabricated Grease Duct (Item 1). Use min. 1/2 in. diameter threaded steel rods. Attach the threaded steel rods to the Floor/Ceiling Assembly (Item 4A) by

way of through-holes sized appropriately for the nominal threaded rod diameter and secured on top side with appropriately sized flat washer and double nut. Place one threaded steel rod on each side of the Pre-Fabricated Grease Duct (Item 1) and fasten to the support member with appropriately sized nuts (see Figure 1, Detail A). Install the rods at a max. of 1 in. from each side of the Pre-Fabricated Grease Duct (Item 1). Space horizontal supports a max. of 12 ft. on center (oc). Reduce the support spacing for larger ducts to ensure that the load on each hangar (set of two threaded rods and support member) does not exceed 500 lb. Alternatively, use manufacturer-supplied, min. 2 in. wide, min. 11 GA, steel Hangar Bands (BHB) as the supporting member, and reduce the max. load per hangar to 420 lb.



- B. VERTICAL SUPPORTS – Reference Figures 3, 4, and 5. Where the Pre-Fabricated Grease Duct (Item 1) is installed vertically, use the Plate Support Assembly (PLS), Flange Support Assembly (FSA), and/or Wall Brackets (WBR) as specified below.
- i. SUPPORTING CONSTRUCTION – Use supporting construction determined by the responsible structural project engineer as appropriate to support four times the load of the Pre-Fabricated Grease Duct (Item 1) and meeting the requirements of the IMC, NFPA 96, or other applicable regulatory requirement. See the manufacturer’s weight specifications to determine weight for the corresponding duct sizes.
 - ii. PLATE SUPPORT ASSEMBLY (PLS) – Secure the Pre-Fabricated Grease Duct (Item 1) sections joined with the PLS (reference Figure 3) to the supporting construction (supplied by others). Ensure the PLS is supported continuously on all sides. Fasten the PLS to the supporting construction at min. on each of the four corners using appropriate type fasteners for the intended construction and as specified by the responsible design professional. Ensure that the supports are spaced such as not to exceed a max. load of 2,400 lb.
 - iii. FLANGE SUPPORT ASSEMBLY (FSA) – Secure the Pre-Fabricated Grease Duct (Item 1) sections with integral FSA (reference Figure 4) to the supporting construction (supplied by others). Ensure the FSA is supported continuously on all sides. Fasten the FSA to the supporting construction at min. on each of the four corners using appropriate type fasteners for the intended construction and as specified by the responsible design professional. Ensure that the supports are spaced such as not to exceed a max. load of 3,400 lb.
 - iv. HALF FLANGE SUPPORT ASSEMBLY (HFS) – The Half Flange Support Assembly is like the Flange Support Assembly, except it is only intended to support the duct on two opposite flanges; the non-supporting flanges are shorter. Secure the Pre-Fabricated Grease Duct (Item 1) sections with integral HFS to the supporting construction (supplied by others). Ensure the HFS is supported continuously on two opposite sides (the sides with the wider flanges). Fasten the FSA to the supporting construction at min. on each of the four corners using appropriate type fasteners for the intended construction and as specified by the responsible design professional. Ensure that the supports are spaced such as not to exceed a max. load of 2,500 lb.

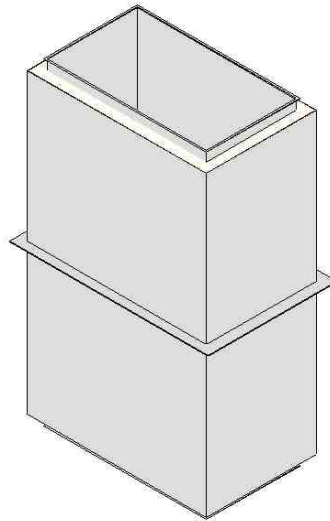

Figure 4. Flange Support Assembly (FSA)

- v. WALL BRACKETS (WBR) – Secure the wall brackets (Reference Figure 5) to supporting construction using a min. of six 1/2 in. bolts/anchors (three per bracket). Use appropriate type fasteners for the intended construction and as specified by the responsible design professional. Mount the Pre-Fabricated Grease Duct (Item 1) to the wall brackets using either the Plate Support Assembly (Item 3Bii) or the Flange Support Assembly (Item 3Biii) using min. 3/8 in.

bolts and nuts. Use a min. of three bolts per wall bracket for ducts with nominal inside dimension less than 18 in. on the mounting side. Add a fourth bolt for larger ducts. Ensure that the supports are spaced such as not to exceed a max. load as shown below:

- Nominal Duct Size \leq 32 in.: Max. 1,312 lb.
- Nominal Duct Size $>$ 32 in.: Max. 902 lb.

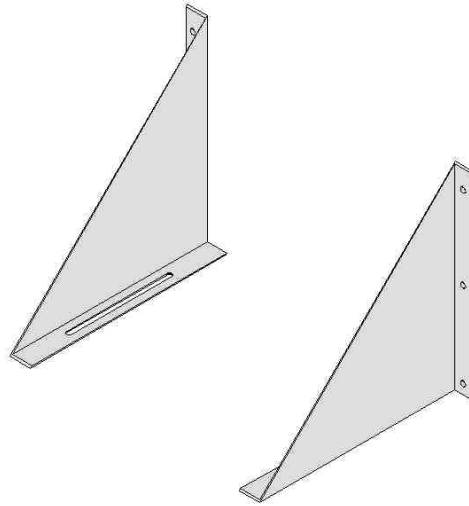

Figure 5. Wall Bracket (WBR)

C. FLOOR/CEILING PENETRATION SUPPORT
– Where the Pre-Fabricated Grease Duct (Item 1) penetrates a fire-rated floor/ceiling (Item 4A), use the Plate Support Assembly (PLS) (Item 2E) or the Flange Support Assembly (FSA) (Item 3Biii). Follow the manufacturer's installation instructions and the requirements indicated below:

- i. Use appropriate non-combustible supporting construction (Item 3Bi) as determined by the responsible design professional. Ensure that the supporting construction provides continuous support on all sides of the Plate Support Assembly (Item 2E) or the Flange Support Assembly (Item 3Biii).
- ii. When required, use the Plate Support Assembly (Item 2E) joint method to join the penetrating section of duct to the next duct section above the floor/ceiling assembly.

- iii. Secure the Plate Support Assembly (Item 2E) to the supporting construction or the Flange Support Assembly (Item 3Biii) by welding or mechanically fastening using min. 1/2 in. steel bolts, nuts, and washers. Use a min. of one bolt or one 1-1/2 in. long weld at each of the four corners.

4. FLOOR/CEILING PENETRATION FIRESTOP:
When required to penetrate a fire-rated floor/ceiling assembly, install the firestop system described in Items 4A to 4E (reference Figure 6).

- A. FLOOR/CEILING ASSEMBLY – Penetrate a two-hour fire-rated, solid concrete floor/ceiling assembly made from reinforced lightweight or normal weight (100-150 pcf or 1,600-2,400 kg/m³) concrete, and having a min. thickness of 4.6 in. Create a rectangular through-opening in the floor/ceiling assembly so that the opening dimensions are greater than the outside dimensions by 1 in. to 4 in. The size of the through-opening shall



not exceed 40-1/4 in. x 61-1/4 in. Position the Pre-Fabricated Grease Duct (Item 1) concentrically or eccentrically in the through-opening so that the annular space ranges from min. 1 in. to max. 4 in.

- B. **BOTTOM FIRESTOP PLATE** – Use the supplied bottom firestop plate (two halves required) consisting of 3 in. x 6 in. x 1/8 in. steel angle. Position the Bottom Firestop Plate around the Pre-Fabricated Grease Duct with the 6 in. leg positioned against the underside of the floor/ceiling assembly (Item 4A). Secure the Bottom Firestop Plate to the concrete floor/ceiling assembly (Item 4A) using 1-3/4 in. long, 1/4 in. concrete screws. Use all the pre-drilled holes on the Bottom Firestop Plates. Secure the Bottom Firestop Plate to the Pre-Fabricated grease Duct (Item 1) using No. 6, 3/4 in. long, hex washer, sheet metal screws. Use 3M™ Fire Barrier Sealant CP 25WB+ or other approved firestop sealant to fill any gaps between the Bottom Firestop Plate and the floor/ceiling assembly or the duct.
- C. **PACKING MATERIAL** – Fill the annular space between the Pre-Fabricated Grease Duct (Item 1) and the floor/ceiling assembly (Item 4A) with insulation supplied by the duct manufacturer, which is nominal 1 in. or 1-1/2 in. thick, and of the same type and density as the annular insulation used in the Pre-Fabricated Grease Duct. Install insulation in horizontal layers, staggering joints at the corners, and compressed to a min. 36%. Recess the packing material nominal 3/8 in. from the top of the floor/ceiling assembly (Item 4A).

- D. **CERTIFIED COMPANY** – 3M Company
- CERTIFIED PRODUCT – Sealant
 - MODEL – 3M™ Fire Barrier™ Water-Tight 1000-NS Silicone, 1000-SL Silicone, 2000+ Silicone, or CP 25WB+

CERTIFIED COMPANY – Tremco Incorporated

- CERTIFIED PRODUCT – Sealant
- MODEL – TREMstop Silicone Fyre-Sil® GG and Fyre-Sil® SL

LISTED COMPANY – Specified Technologies Incorporated (STI)

- LISTED PRODUCT – Sealant
- MODEL – SpecSeal® Series SSS

LISTED COMPANY – HILTI

- LISTED PRODUCT – Sealant
- MODEL – FS-ONE

FILL, VOID, OR CAVITY MATERIAL – Use one of the sealants listed above. Fill the nominal 3/8 in. recess created over the packing material and screed the sealant flush with the top surface of the floor/ceiling assembly (Item 4A). Overlap the sealant a min. of 1/2 in. onto the face of the Pre-Fabricated Grease Duct (Item 1) and onto the floor/ceiling assembly. Allow the sealant to skin-over prior to proceeding to the next installation step.

- E. **TOP FIRESTOP PLATE** – Use the supplied top firestop plate (two halves required) consisting of a 1/8 in. thick, T-shaped steel form used to create a 4 in. wide and 5 in. deep collar around the perimeter of the Pre-Fabricated Grease Duct (Item 1). Secure the Top Firestop



Plate to the top of the floor/ceiling assembly with 1-3/4 in. long, 1/4 in. concrete screws. Use all the pre-drilled holes on the Top Firestop Plates. Fill the cavity created by the Top Firestop Plate with insulation supplied by the duct manufacturer, which is nominal 1 in. or 1-1/2 in. thick, and of the same type and

density as the annular insulation used in the Pre-Fabricated Grease Duct. Install insulation in horizontal layers with staggered joints at the corners and min. 1-1/2 in. widthwise compression. Install cover plate over exposed insulation (optional).

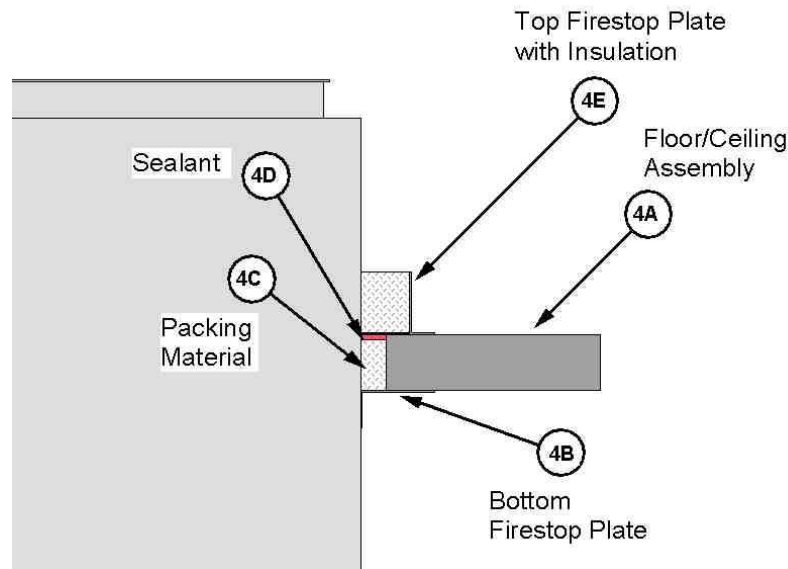

Figure 6. Floor/Ceiling Firestop

5. WALL PENETRATION FIRESTOP: When required to penetrate a fire-rated wall assembly, install the firestop system described in Items 5A to 5D (reference Figure 7).

A. WALL ASSEMBLY – Penetrate a two-hour fire-rated wall assembly of one of the following constructions listed below in Items 5Ai through 5Aiii. Form, cut, or frame, as applicable, a rectangular through-opening in the wall assembly so that the opening dimensions are greater than the outside dimensions by 1 in. to

4 in. The size of the through-opening shall not exceed 40-1/4 in. x 61-1/4 in. Position the Pre-Fabricated Grease Duct (Item 1) concentrically or eccentrically in the through-opening so that the annular space ranges from min. 1 in. to max. 4 in.

i. CONCRETE – Penetrate a symmetrical, solid concrete, wall assembly made from reinforced lightweight or normal weight (100-150 pcf or 1,600-2,400 kg/m³) concrete, and having a min. thickness of 4.6 in.



- ii. **MASONRY** – Penetrate a symmetrical nominal 8 in. x 8 in. x 16 in. (203 mm x 203 mm x 406 mm) concrete masonry unit (CMU) wall assembly, made from lightweight or normal weight (100-150 pcf or 1,600-2,400 kg/m³) concrete. Use solid block around the through-penetration opening.
- iii. **GYPHUM/STEEL STUD** – Penetrate a symmetrical two-hour rated gypsum wall assembly constructed of the following:
- **Steel Studs:** Min. 25 GA galvanized steel stud measuring 3-5/8 in. (92 mm) wide with 1-1/4 in. (32 mm) legs spaced max. 24 in. (610 mm) oc. Attach studs to floor and ceiling tracks in accordance with the corresponding listed design. Frame out the through-opening with steel framing. Install additional framing as required to match the hole pattern of the Wall Firestop Plate (Item 5D)
 - **Gypsum Board:** Cover studs and runners with two layers of 5/8 in. (16 mm) thick, Type X gypsum board on each face. Install gypsum board in accordance with the corresponding listed design.
- B. **PACKING MATERIAL** – Fill the annular space between the Pre-Fabricated Grease Duct (Item 1) and the wall assembly (Item 5A) with insulation supplied by the duct manufacturer, which is nominal 1 in. or 1-1/2 in. thick, and of the same type and density as the annular insulation used in the Pre-Fabricated Grease Duct. Install insulation in layers, staggering joints at the corners, and compressed to a min. 36%. Recess the packing material nominal 5/8 in. from each side of the wall assembly (Item 5A).
- C. **CERTIFIED COMPANY** – 3M Company
- **CERTIFIED PRODUCT** – Sealant
 - **MODEL** – 3M™ Fire Barrier™ Water-Tight 1000-NS Silicone, 2000+ Silicone, or CP 25WB+
- CERTIFIED COMPANY** – Tremco Incorporated
- **CERTIFIED PRODUCT** – Sealant
 - **MODEL** – TREMstop Silicone Fyre-Sil® GG
- LISTED COMPANY** – Specified Technologies Incorporated (STI)
- **LISTED PRODUCT** – Sealant
 - **MODEL** – SpecSeal® Series SSS
- LISTED COMPANY** – HILTI
- **LISTED PRODUCT** – Sealant
 - **MODEL** – FS-ONE
- FILL, VOID, OR CAVITY MATERIAL** – Use one of the sealants listed above. Fill the nominal 5/8 in. recesses created over the packing material from each side of the wall assembly (Item 5A) and screed the sealant flush with the wall assembly. Overlap the sealant a min. of 1/2 in. onto the face of the Pre-Fabricated Grease Duct (Item 1) and onto the wall assembly. Allow the sealant to skin-over prior to proceeding to the next installation step.
- D. **WALL FIRESTOP PLATE** – Use the supplied Wall Firestop Plates (two halves required for each side of wall) consisting of a 1/8 in. thick, T-shaped steel form used to create a 4 in. wide and 5 in. deep collar around the perimeter of the Pre-



Fabricated Grease Duct (Item 1). Secure the Wall Firestop Plates to each side of the wall assembly (Item 5A) with 1-3/4 in. long, 1/4 in. concrete or masonry screws, or 2 in. long, 1/4 in. self-drilling screws. Use all the pre-drilled holes on the Wall Firestop Plates. Fill the cavity created by the Wall Firestop Plate with insulation supplied by the duct

manufacturer, which is nominal 1 in. or 1-1/2 in. thick, and of the same type and density as the annular insulation used in the Pre-Fabricated Grease Duct. Install insulation in layers with staggered joints at the corners and min. 1-1/2 in. widthwise compression. Install cover plate over exposed insulation (optional).

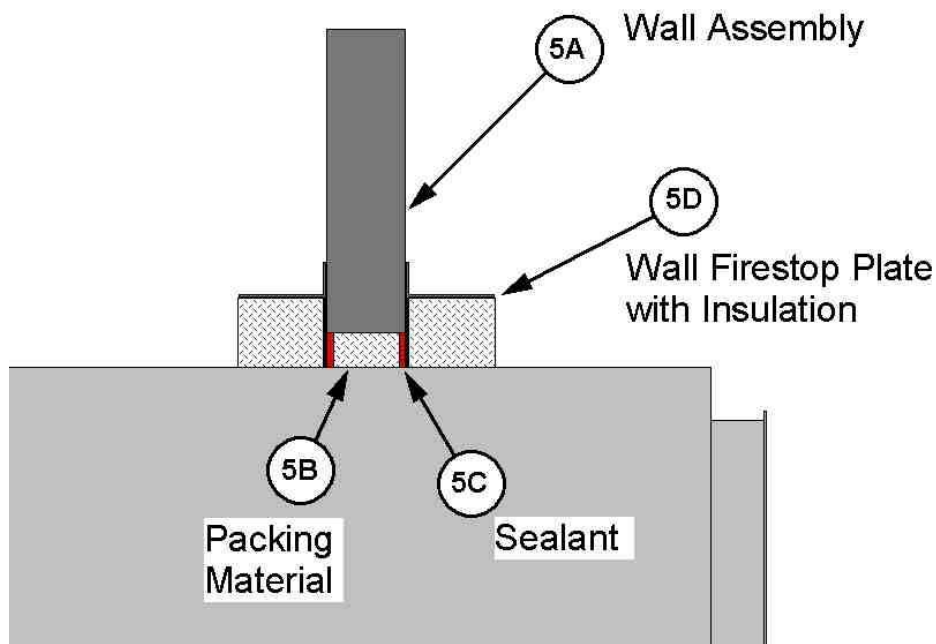

Figure 7. Wall Firestop