

Sun Air
Design Number SA/FMF 120-01
FIRE GREASE DUCT
Double Wall Duct
UL 2221

Internal Fire Test, Condition B – Pass (See Table 1)

Fire-Engulfment Test – 2 Hour

CAN/ULC-S662 – Pass (See Table 1)

ASTM E814

F-Rating, T-Rating: 2 Hour

UL1978 – Pass (See Table 1)

CAN/ULC S115

F-, FT-, FH-, FTH-Rating: 2 Hour

Table 1: Clearance to Combustibles Compliance

Models and Duct Size	Clearance to Combustibles
Model SADW-2R: Up to 16 in.	3/4 in.
Model SADW-2R: 18 in.	1 in.
Model SADW-3R: Up to 24 in.	3/4 in.

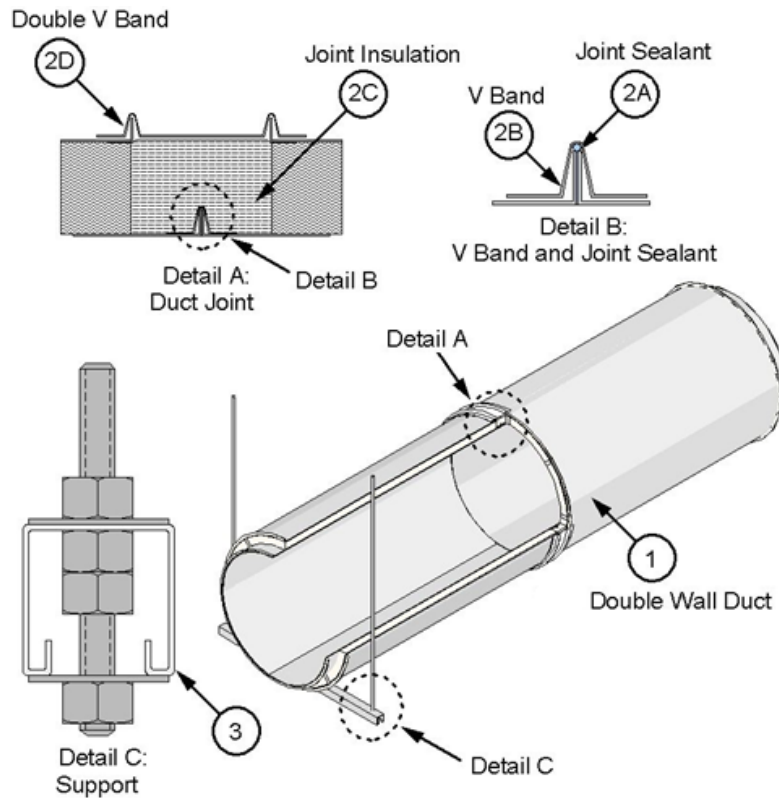

Figure 1. Double Wall Duct and Horizontal Support

1. CERTIFIED MANUFACTURER:

Sun Air

CERTIFIED PRODUCT: Pre-Fabricated Grease Duct**MODEL:** Double Wall Duct
SADW-2R and SADW-3R

PRE-FABRICATED GREASE DUCT: Install grease ducts in compliance with the requirements of NFPA 96, the International Mechanical Code (IMC), or the National Building Code of Canada (NBCC) as applicable. For UL 1978 and UL 2221 applications, install at a slope of not less than 1/16 (0.0625) unit vertical in 12 units horizontal toward the hood or toward a grease reservoir. Where horizontal ducts exceed 75 ft in length, the slope shall be not less than 3/16 (0.1875) unit vertical in 12 units horizontal. Obtain AHJ approval for these alternate methods. Use the Intertek Certified pre-fabricated grease duct identified above and having the following features and/or specifications:

A. DUCT SIZE (Nominal Inside Diameter):

- Model SADW-2R: Up to 18 in.
- Model SADW-3R: Up to 24 in.

- B. ACCESS DOOR –** When required, use the duct manufacturer's manifold tee and access door (tee cap) assembly (see Figure 2). Apply a 1/4 in. continuous bead of sealant (Item 2A) to the inner flange of the tee on the side where access door is to be located. Center the supplied grease dam over the opening of the tee. Verify that the grease dam is sealed to the tee flange by applying pressure. Remove excess sealant (Item 2A). When the sealant (Item 2A) is dry attach the supplied inner access door using a V band (Item 2B). Tighten 1/4-20 hardware to 40-60 in.lbs. Install access door collar to manifold tee with V band (Item 2B) and tighten the 1/4-20 hardware to 40-60 in.lbs. Install joint insulation (Item 2C) in the annular space created between inner duct and the access door collar, using the same insulation type and number of layers as required for other joints detailed in Item 2. Over the access door, install three layers of the supplied, circular, pre-cut, nominal 1 in. thick insulation of the same type and density as used in the pre-fabricated grease duct (Item 1). Secure outer access door to outer access door collar using V band (Item 2B); tighten the 1/4-20 hardware to 40-60 in.lbs.

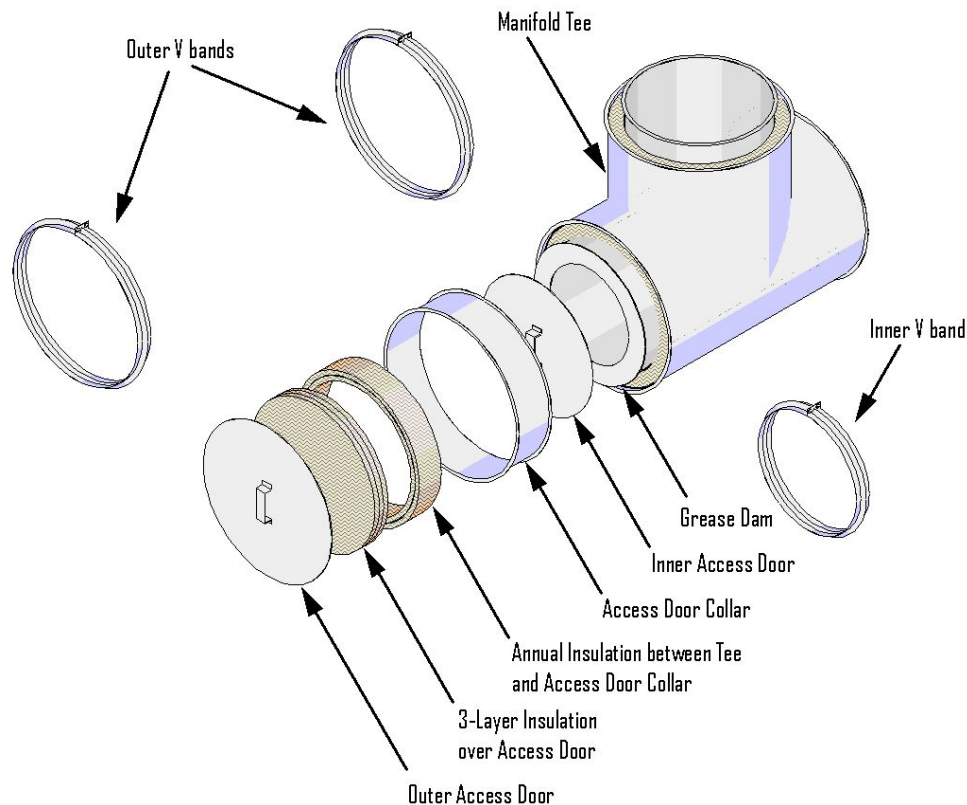

Figure 2. Access Door Assembly

C. Rigidly support the pre-fabricated grease duct (Item 1) as specified below in Item 3 or in accordance with IMC, NBCC, or NFPA 96 requirements, as applicable, when not specified herein or when those requirements are greater.

D. Protect the annular space around the pre-fabricated grease duct (Item 1) passing through a fire-rated floor/ceiling assembly or a fire-rated wall assembly as specified in Items 4 and 5, respectively.

2. JOINTS: Join the pre-fabricated grease duct (Item 1) sections using the following components and methods:

A. **CERTIFIED MANUFACTURER:**
3M Company

CERTIFIED PRODUCT: Sealant

MODEL: 3M Fire Barrier™ 2000+

JOINT SEALANT – Fill the V band (Item 2B) with a continuous bead of sealant. Apply a continuous 1/4 in. bead of sealant to one of the inner duct flanges to be joined.

B. **V BAND** – Use the supplied V band (see Figure 1). Place the loose V band, filled with joint sealant (Item 2A), over one of the inner duct flanges. Join to the other inner duct flange with the continuous bead of joint sealant (Item 2A) and rotate slightly to ensure complete coverage of joint sealant (Item 2A) on flanges. Ensure that the flanges are located within the V band and that the V band hardware is not at the bottom side of a horizontal duct. Tap the V band while tightening the integral 1/4-20



hardware to ensure flanges are aligned and pulled together. Tighten to 40-60 in.lbs.

- C. **JOINT INSULATION** – Use the supplied joint insulation, which is a min. of 4-1/2 in. wide, and of the same type, density and thickness as the insulation used in annular space of the pre-fabricated grease duct (Item 1).
- Model SADW-2R: Wrap the 4-1/2 in. wide joint insulation around the connection to create two layers of insulation and add a min. 3 in. overlap on the final turn.
 - Model SADW-3R: Wrap the 4-1/2 in. wide joint insulation around the connection to create three layers of insulation and add a min. 3 in. overlap on the final turn.
- D. **DOUBLE V BAND** – Use the supplied double V band (see Figure 1). Place double V band with outer shell flanges seated in the V band; tighten integral 1/4-20 hardware to 40-60 in.lbs.

3. SUPPORTS: Follow the requirements for horizontal and vertical supports in Items 3A, 3B, and 3C below. When applicable, ensure that the max. unsupported inclined length of duct does not exceed the max. horizontal support spacing specified in Item 3A.

- A. **HORIZONTAL SUPPORTS** – Support the pre-fabricated grease duct (Item 1) using min. 12 GA, 1-5/8 in. x 1-5/8 in. Unistrut® channel or 2 in. x 2 in. x 1/4 in. steel angle as the supporting cross-member and two, min. 1/2 in. diameter, threaded steel rods connected using Grade 5 hex nuts and 1/2 in. hardened washers (see Figure 1, Detail C). Connect the threaded steel rods to the bottom of the floor assembly using an attachment method designed to carry the weight of the pre-fabricated grease duct (Item 1) under a fire load equivalent to ASTM E 119 time-temperature curve for a 2

hour period. Place one threaded steel rod at each end of the supporting cross-member. Center the pre-fabricated grease duct (Item 1) on the cross-member. Space the threaded steel rods a max. of 8 in. from surface of the pre-fabricated grease duct (Item 1). Cut the cross-members such that each extends a min. 1-1/2 in. past the threaded steel rods. Space horizontal supports a max. of 84 in. on center (oc) for ducts with nominal diameter ≤ 16 in., and a max. of 60 in. oc for nominal 18 in. to 24 in. diameter ducts; maintain a max. ductwork weight of 258 lb. between supports.

- B. **VERTICAL SUPPORTS (Wall)** – Use the vertical support assemblies supplied by the duct manufacturer and consisting of the following 12 GA steel components:
- Wall-Plates – two required
 - Side-Plates – two required, left side and right side
 - Top-Plates – two required, front and rear

Where the pre-fabricated grease duct (Item 1) is installed vertically along a wall as depicted in Figure 3 below, provide supports at least every 20 ft for ≤ 16 in. inside diameter Model SADW-2R, 18 ft for 18 in. inside diameter Model SADW-2R, and at least every 12 ft for Model SADW-3R, and per the following requirements:

- a. **Weight Limit:** Maintain max. 423 lb. of ductwork between vertical supports.
- b. **Steel Stud Wall Installation:**
- Use the hardware listed below to mount the vertical support assembly and secure it to the pre-fabricated grease duct (Item 1) as described in the sections to follow.
 - i. 5/16 in. x 1-1/2 in. long self-drilling, serrated hex-washer-head, sheet metal screws.



- ii. 5/16-18 toggle bolts.
 - iii. Min. 0.060 in. thick, 1-1/8 in. OD flat washers with clearance ID for 5/16 in. screws and bolts.
 - iv. 5/16-18 serrated hex-washer-head, nuts and bolts.
- Use two wall-plates per support. When possible, use pre-punched holes on wall-plates for fastener positions. If necessary, drill additional holes in wall-plate to accommodate irregular stud spacing or to align with support side-plate mounting holes.
 - Install each wall plate with length oriented horizontally. Position one wall-plate directly above the other. Space the wall-plates vertically a nominal 36 in. oc, adjusted as required to align with the mounting hole patterns on the support side-plates.
 - Fasten wall-plates and at least one vertical support side-plate to steel-studs. Ensure that the wall-plates span and fasten to at least two steel studs. For each wall-plate use sheet metal screws at min. four locations per stud (two on top and two on bottom), except if there is interference with the vertical support top-plate; in this case exclude the sheet metal screw from the top hole. In addition, use two toggle bolts per stud to secure each wall plate and at least one vertical support side-plate to the steel studs in center 7/8 in. diameter pre-drilled holes.
 - Space the support-side plates such that the support top-plate mounting holes align with the bolt holes on top of the support side-plates. Ensure that the support side-plates are located such that both are secured to the wall assembly through the wall-plates.
 - For support side-plate(s) fastened to a steel stud, install four more toggle bolts into second set of pre-drilled holes in side plate (two on top mount and two on bottom mount) to secure to the wall assembly through the wall-plates. When possible, use the 7/8 in. diameter, pre-drilled holes in the wall-plates.
- When a support side-plate is not fastened to a steel stud use eight toggle bolts (four on top mount and four on bottom mount) to secure to the wall assembly through the wall-plates using pre-drilled holes when possible.
 - Fasten the rear top-plate to the support side-plates using 5/16-18 serrated hex-washer-head nuts and bolts. Position the top-plate directly against wall assembly with back flange up or offset the top-plate up to three bolt holes (6 in.) away from wall assembly. Use fasteners in no less than every other bolt hole and at rear-most bolt hole and front-most bolt hole.
 - Install joined pre-fabricated grease duct (Item 1) sections with the double V band (Item 2D) lower "V" supported by the top-plate and with the double V band (Item 2D) hardware directly facing toward or away from the wall assembly so that the hardware fits in the cut-out of a top-plate. Secure the pre-fabricated grease duct (Item 1) sections to the support side-plates using eighteen 5/16 in. x 1-1/2 in. long self-drilling, serrated hex-washer-head, sheet metal screws per side. Use the pre-drilled holes in the side-plates to locate the screws.
 - Fasten the front top-plate to the top of the support side-plates, oriented with the top-plate front-flange up and using 5/16-18 serrated hex-washer-head nuts and bolts. Use fasteners in no less than every other bolt hole, and at rear-most bolt hole and front-most bolt hole where it can still be secured to the side-plates.



- b. Wood Stud Wall Installation:
Comply with the same installation requirements as for steel stud wall installation, except use 5/16 in. x 3-1/2 in. long lag bolts when fastening to wood studs.
- c. Concrete or Masonry Wall Installation:
Comply with the same installation requirements as for steel stud wall installation except:
- Exclude wall-plates.
 - Fasten support side-plates to wall assembly using appropriate type and size concrete anchors but having min. 5/16 in. diameter and min. 2-1/4 in. length.
- C. VERTICAL PENETRATION SUPPORT – Where the pre-fabricated grease duct (Item 1) penetrates a fire-rated floor/ceiling assembly as specified in Item 4:
- a. Use the support assemblies supplied by the duct manufacturer, made of min. 12 GA steel components, including full support ring (two halves mechanically fastened together), steel angle struts, and steel angle floor brackets. Use supplied 5/16-18 hardware to assemble and fasten components per manufacturer's instructions.
- b. Use 1 in. wide support ring for ducts with nominal diameter \leq 16 in., and use 1-1/2 in. wide support ring for ducts with nominal diameter $>$ 16 in. Position support ring directly under double V band (Item 2D).
- c. Use 1-1/2 in. x 1-1/2 in. steel angle struts and floor brackets; use max. 24 in. strut length.
- d. Secure to concrete floor using floor brackets and appropriate type and size concrete anchors but having min. 3/8 in. diameter and min. 2-1/4 in. length.
- D. CURB VERTICAL SUPPORTS – Use the curb vertical support assembly (see Figure 3) supplied by the duct manufacturer and consisting of a min. 20 GA aluminized steel welded curb and a duct section with min. 16 GA aluminized steel transition plate welded to the inner duct. Secure the curb to supporting floor/ceiling or roof/ceiling construction consisting of min. 2 x 8 lumber and min. 1/2 in. wood structural panels and designed by the responsible design professional to support all applicable load conditions. Use oversized, zinc plated, steel flat washers for 3/8 in. screws and 3/8 in. diameter, min. 1-1/2 in. long, zinc-plated steel lag screws to secure the curb through supporting construction with max. 12 in. oc fastener spacing. Ensure the opening is framed with min. 2 x 8 lumber such that all four sides of the curb are supported. Drop the duct section with welded transition plate through the curb and secure the transition plate to the curb with 2 in. long, 1/4-14, stainless steel, hex-washer-head, self-drilling screws spaced max. 12 in. oc. Ensure the max. weight of grease duct (Item 1) supported by each curb does not exceed 1,162 lb. Ensure the max. length of grease duct (Item 1) supported by each curb vertical does not exceed 53 ft for \leq 16 in. inside diameter Model SADW-2R grease ducts, 51 ft for 18 in. Model SADW-2R grease ducts, and 33 ft for Model SADW-3R grease ducts.
- E. FLOOR SUPPORT ASSEMBLY – Use the floor support assembly (see Figure 3) supplied by the duct manufacturer and consisting of two 12 GA galvanized steel half-plates with 14 GA galvanized steel half-bands riveted to



the half-plates with 14 GA galvanized steel angle brackets. Secure the floor support assembly plates to the supporting floor/ceiling or roof/ceiling construction consisting of min. 2 x 8 lumber and min. 1/2 in. wood structural panels and designed by the responsible design professional to support all applicable load conditions. Use oversized, zinc plated, steel flat washers for 3/8 in. screws and 3/8 in. diameter, min. 1-1/2 in. long, zinc-plated steel lag screws to secure the half-plates to supporting construction with max. 12 in. oc fastener spacing along the long side of the half-plates and max. 6 in. oc fastener spacing along the short side of the half-plates. Ensure the opening is framed with min. 2 x 8 lumber such that all four sides of the floor support assembly are supported. Position the duct within the support assembly such that it does not interfere with the outer Double V Band (Item 2D). The Double V Band may rest directly on the support assembly if required. Secure the half-bands to the outer duct wall using No. 8 by 1/2 in. long self-drilling, K-lath-head, zinc plated steel screws. Use a min. of three screws between angle brackets in an alternating up and down pattern as shown in Figure 3. Secure the half-bands together using supplied hardware. Ensure the max. weight of grease duct (Item 1) supported by each floor support assembly does not exceed 1,162 lb. Ensure the max. length of grease duct (Item 1) supported by each floor support assembly does not exceed 53 ft for ≤ 16 in. inside diameter Model SADW-2R grease ducts, 51 ft. for 18 in. Model SADW-2R grease ducts, and 33 f. for Model SADW-3R grease ducts.

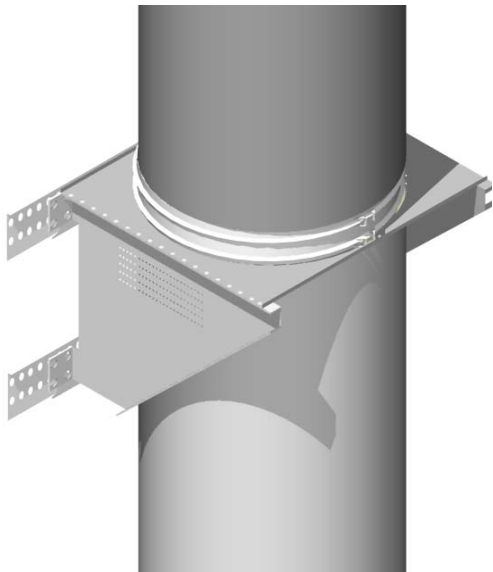

Vertical Wall Support

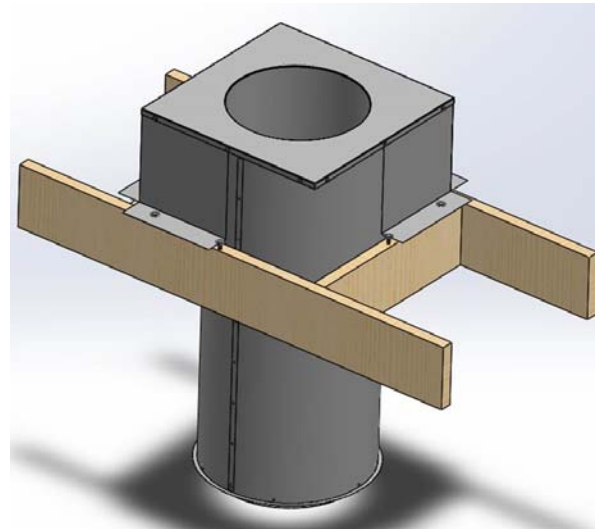

Curb Vertical Support

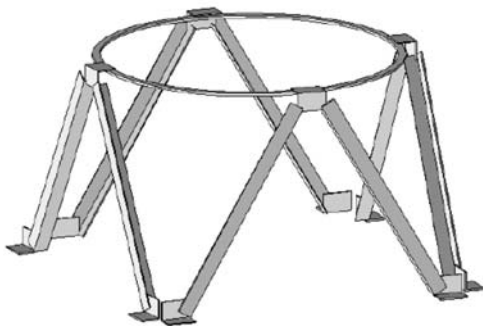

Vertical Penetration Support

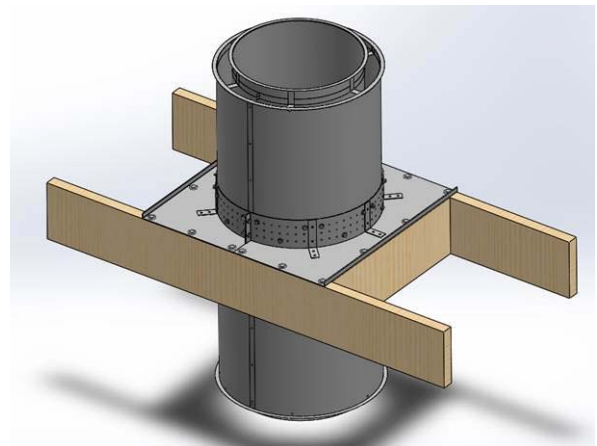

Floor Support Assembly

Figure 3. Vertical Supports

4. FLOOR/CEILING PENETRATION FIRESTOP:

When required to penetrate a fire-rated floor/ceiling assembly, install the firestop system described in Items 4A to 4F (see Figure 4).

A. FLOOR/CEILING ASSEMBLY – Penetrate a 2-hour fire-rated, solid concrete floor/ceiling

assembly made from reinforced lightweight or normal weight (100-150 pcf or 1,600-2,400 kg/m³) concrete, and having a min. thickness of 4.6 in. Create a square or round opening in the floor/ceiling assembly so that the opening width or diameter is 2 in. to 3 in. greater than the outside diameter of the pre-fabricated grease duct (Item 1). Position the pre-



fabricated grease duct (Item 1) concentrically or eccentrically in the opening so that the annular space ranges from min. 1 in. to max. 2 in. For a square opening, measure the annular space normal to both the duct wall and the nearest vertical face of the floor opening.

- B. CLOSURE PLATES – Use the two supplied closure plates, constructed of min. 18 GA steel and cut to fit around the duct with a min. 1 in. plate-on-plate overlap and a 3 in. min. overlap onto the bottom of the floor/ceiling assembly (Item 4A). Apply a continuous 1/2 in. bead of fill, void, or cavity material (Item 4D) around the perimeter of the closure plates. Push the plates up against the bottom of the floor/ceiling assembly (Item 4A) such that the applied fill, void, or cavity material (Item 4D) seals against the floor/ceiling assembly (Item 4A). Secure the closure plates to the floor/ceiling assembly (Item 4A) using 1/4-20 x 1-1/2 in. long concrete fasteners spaced max. 9-1/2 in. oc. Fasten the closure plates to each other at the overlap using 1/4-20 x 1 in. long metal screws, two on each side. Apply a 1 in. bead of fill, void, or cavity material (Item 4D) to the top side of the closure plates along perimeter of opening in the floor/ceiling assembly (Item 4A) and around the pre-fabricated grease duct (Item 1).
- C. PACKING MATERIAL – Fill the annular space between the pre-fabricated grease duct (Item 1) and the floor/ceiling assembly (Item 4A) with insulation supplied by the duct manufacturer, which is nominal 1 in. thick and of the same type and density as the annular insulation used in pre-fabricated grease duct (Item 1). Install a min. of four horizontal layers in the annular space; compress min. 33% of actual insulation thickness such that the insulation is recessed 3/4 in. from top of floor/ceiling

assembly (Item 4A). Fill the entire annular space with the exception of the required recess.

- D. MANUFACTURER:
Specified Technologies, Inc.

LISTED PRODUCT: Sealant

MODEL: SpecSeal® Series SSS

FILL, VOID, OR CAVITY MATERIAL – Apply min. 3/4 in. depth of fill material into the recess over the packing material (Item 4C). Make fill material flush with the top surface of the floor. Overlap the fill material onto the pre-fabricated grease duct (Item 1) a min. of 1 in. and onto the floor/ceiling assembly (Item 4A) a min. of 3 in.

- E. INSULATION COLLAR AND ENCLOSURE BANDS – After the fill, void, or cavity material (Item 4D) has cured enough to "skin over," wrap one layer of insulation to form a collar around the base of the duct on the top side of the floor/ceiling assembly (Item 4A). Use insulation supplied by the duct manufacturer that is nominal 1 in. thick and of the same type as the annular insulation used in the pre-fabricated grease duct (Item 1). Enclose the insulation collar with the two manufacturer-supplied 12 in. tall, half enclosure bands, which are constructed of stainless steel and are equipped with 1/4-20 x 3/4 in. long hardware to secure the enclosure bands together. Ensure that the insulation collar and enclosure bands are in contact with the fill, void, or cavity material (Item 4D), and ensure that the fill, void, or cavity material (Item 4D) seal is not broken or otherwise compromised.
- F. SUPPORT – Install the vertical penetration support (Item 3B), with full support ring installed directly under the double V band (Item 2D).

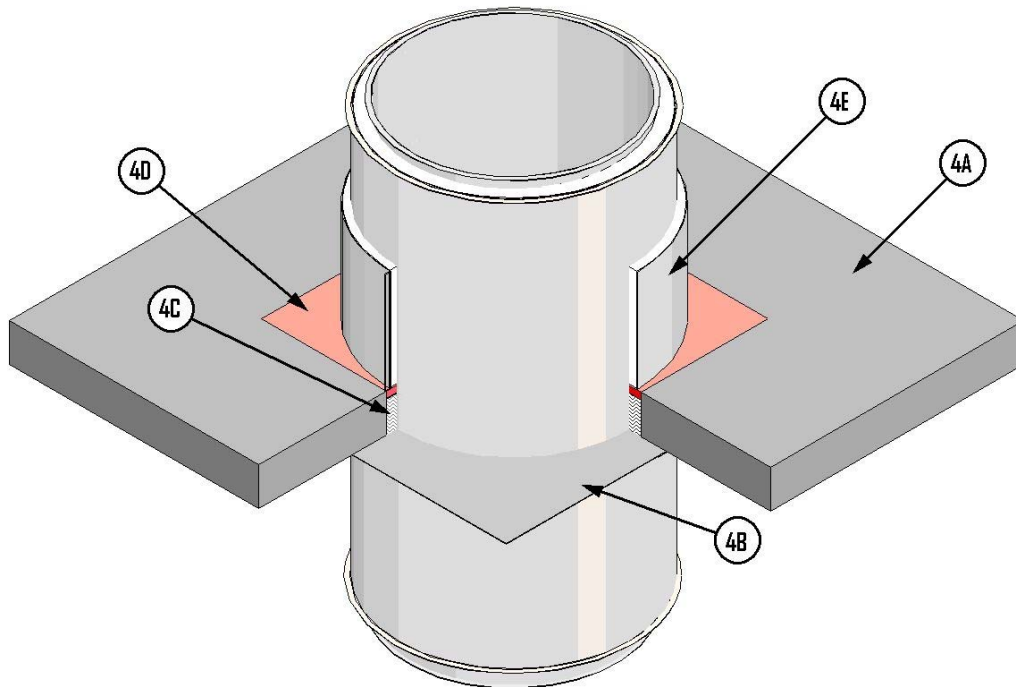

Figure 4: Floor/Ceiling Firestop

5. WALL PENETRATION FIRESTOP: When required to penetrate a fire-rated wall assembly, install the firestop system described in Items 5A to 5F (see Figure 5).

A. **WALL ASSEMBLY** – Penetrate a 2 hour fire-rated, solid concrete wall assembly made from reinforced lightweight or normal weight (100-150 pcf or 1,600-2,400 kg/m³) concrete, and having a min. thickness of 4.6 in. Create a square or round opening in the wall assembly so that the opening width or diameter is 2 in. to 3 in. greater than the outside diameter of the pre-fabricated grease duct (Item 1). Position the pre-fabricated grease duct (Item 1) concentrically or eccentrically in the opening so that the annular space ranges from min. 1 in. to max. 2 in. For a square opening, measure the annular space normal to both the pre-fabricated grease duct

(Item 1) wall and the nearest horizontal face of the wall opening.

B. **CLOSURE PLATES** – Use two supplied closure plates per side of wall assembly (Item 5A); closure plates constructed of min. 18 GA steel and cut to fit around the duct with a min. 1 in. plate-on-plate overlap and a 3 in. min. overlap onto the wall assembly (Item 5A). Apply a continuous 1/2 in. bead of fill, void, or cavity material (Item 5C) around the perimeter of two closure plates. Press the first set of closure plates against one side of the wall assembly (Item 5A) such that the applied fill, void, or cavity material (Item 5C) seals against the wall assembly (Item 5A). Secure the first set of closure plates to the wall assembly (Item 5A) using 1/4-20 x 1-1/2 in. long concrete fasteners spaced max. 9-1/2 in. oc. Fasten the first set of closure plates to each other at the overlap using 1/4-



20 x 1 in. long metal screws, two on each side. Install the other two closure plates on the opposite side of the wall after installing the fill, void, or cavity material (Item 5C) and the packing material (Item 5D) as described in Items 5C and 5D. Follow the same procedure used for the first set of closure plates, except exclude the bead of fill, void, or cavity material (Item 5C) on the perimeter of the second set of closure plates.

- C. MANUFACTURER:
Specified Technologies, Inc.

LISTED PRODUCT: Sealant

MODEL: SpecSeal® Series SSS

FILL, VOID, OR CAVITY MATERIAL – Apply min. 3/4 in. thick layer of fill material onto the first set of closure plates (Item 5B) within the annular space created between the pre-fabricated grease duct (Item 1) and the wall assembly (Item 5B). Install packing material (Item 5D) into the annular space as described in Item 5D. Install a min. 3/4 in. thick layer of fill, void, or cavity material into the recess in the annular space. Install fill, void, or cavity material flush with the face of the wall assembly (Item 5A). Overlap the fill material onto the pre-fabricated grease duct (Item 1) a min. of 1 in. and onto the face of the wall assembly (Item 5A) a min. of 3 in.

- D. PACKING MATERIAL – Fill the annular space between the pre-fabricated grease duct (Item 1) and the wall assembly (Item 5A) with insulation supplied by the duct manufacturer, which is nominal 1 in. thick and of the same type and density as the annular insulation used in pre-fabricated grease duct (Item 1). Install a min. of four vertical layers in the annular space; compress min. 33% of actual insulation thickness such that the insulation is recessed 3/4 in. from the face of the wall assembly (Item 5A). Fill the entire annular space with the exception of required recess.
- E. INSULATION COLLAR AND ENCLOSURE BANDS – Wrap one layer of insulation to form a collar around the base of the duct on each side of the wall assembly (Item 5A). Use insulation supplied by the duct manufacturer that is nominal 1 in. thick and of the same type as the annular insulation used in the pre-fabricated grease duct (Item 1). Enclose each of the insulation collars with two manufacturer-supplied 12 in. tall half enclosure bands, which are constructed of stainless steel and are equipped with 1/4-20 x 3/4 in. long hardware to secure the enclosure bands together. Ensure that the insulation collars and enclosure bands are in contact with the fill, void, or cavity material (Item 5C) on each side of the wall assembly (Item 5A).
- F. SUPPORT – Install the horizontal supports (Item 3A) on each side of the wall assembly (Item 5A).

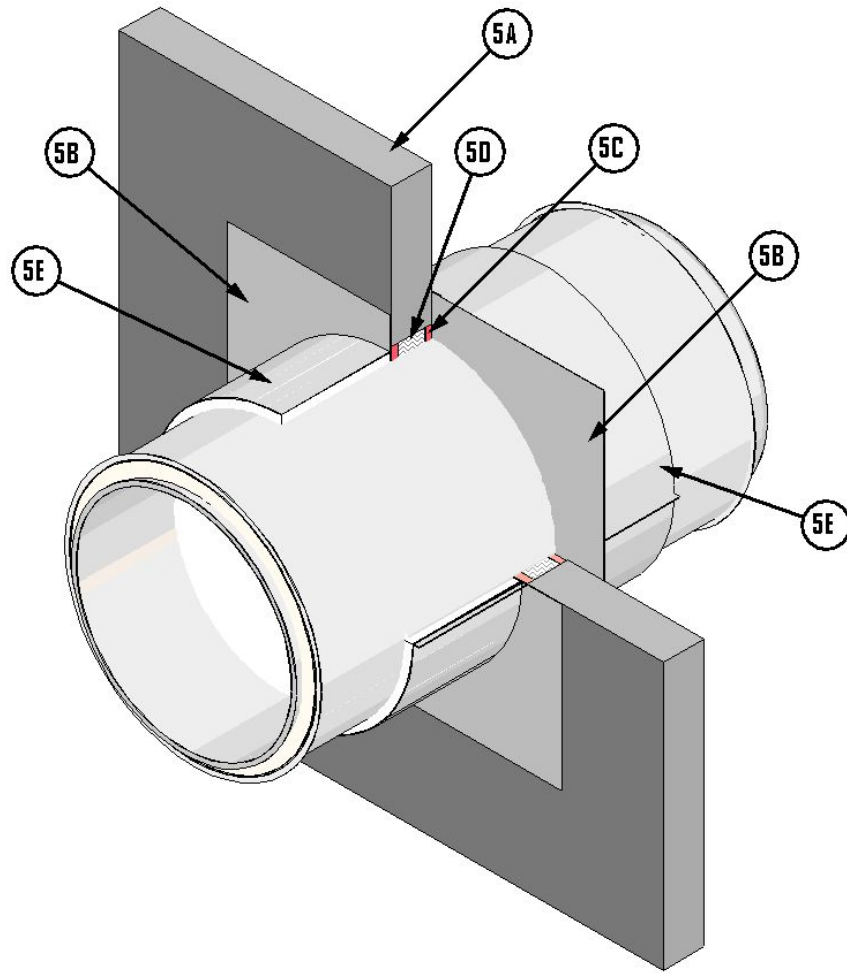

Figure 5. Wall Firestop

Consult the listing report on the Directory of Building Products (<https://bpdirectory.intertek.com>) for the edition of the standard(s) evaluated.