

**Sun Air**  
**Design Number SA/FMF 120-03**  
**FIRE RESISTANT GREASE DUCT**  
**Double Wall Duct**  
**CAN/ULC S144**  
Internal Fire Test – Pass  
Fire-Engulfment Test – Pass  
Fire Resistance Rating – 2 Hour  
**CAN/ULC S115**  
F-, FT-, FH-, FTH-Rating: 2 Hour

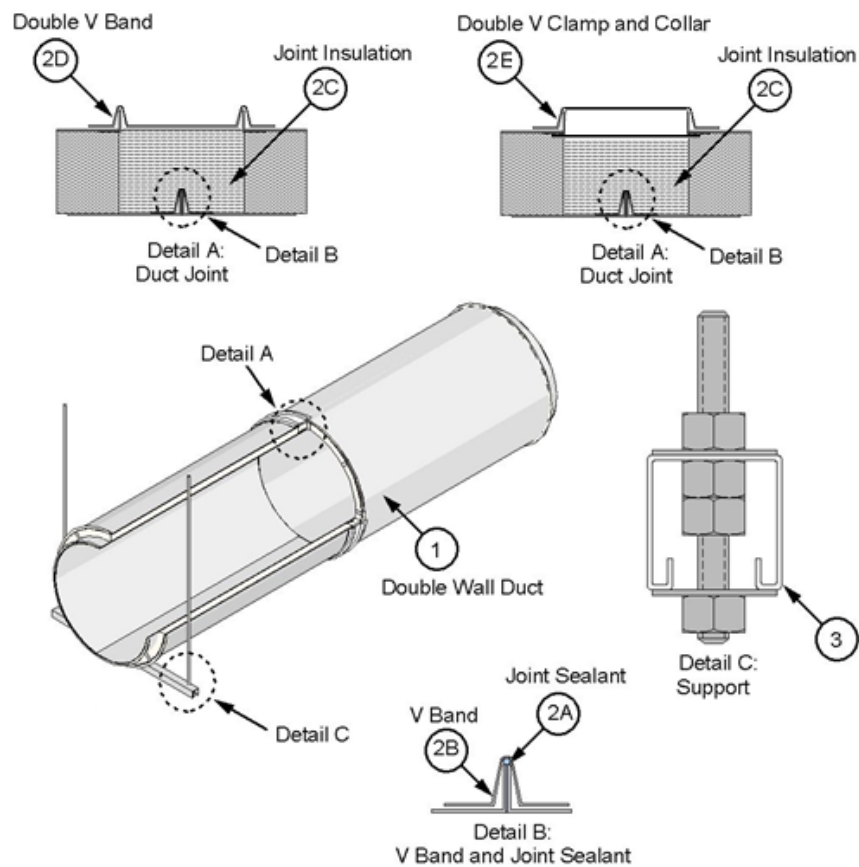

**Figure 1. Double Wall Duct and Horizontal Support**

**1. CERTIFIED MANUFACTURER:**

Sun Air

**CERTIFIED PRODUCT:** Pre-Fabricated Grease Duct

**MODEL:** Double Wall Duct SADW-3Z

**PRE-FABRICATED GREASE DUCT:** Install grease ducts in compliance with the requirements of NFPA 96 and the International Mechanical Code (IMC), or the National Building Code of Canada (NBCC) as applicable. Use the Intertek-Certified pre-



fabricated grease duct identified above and having the following features and/or specifications:

- A. DUCT SIZE (Nominal Inside Diameter) – Up to 36 in.
- B. ACCESS DOOR – When required, use the duct manufacturer’s manifold tee and access door (tee cap) assembly (see Figure 2). Apply a 1/4 in. continuous bead of sealant (Item 2A) to the inner flange of the tee on the side where access door is to be located. Center the supplied grease dam over the opening of the tee. Verify that grease dam is sealed to the tee flange by applying pressure. Remove excess sealant (Item 2A). Apply supplied Garlock Blue-Gard® 3000 gasket to grease dam with a 1/4-in. continuous bead of sealant (Item 2A) applied to the grease dam 1 in. from

the outside edge. When the sealant (Item 2A) is dry attach the supplied inner access door using a V band (Item 2B). Tighten 1/4-20 hardware to 40-60 in.lbs. Install access door collar to manifold tee with V band (Item 2B) and tighten the 1/4-20 hardware to 40-60 in.lbs. Install joint insulation (Item 2C) in the annular space created between inner duct and the access door collar, using the same insulation type and number of layers as required for other joints detailed in Item 2. Over the access door, install three layers of the supplied, circular, pre-cut, nominal 1 in. thick insulation of the same type and density as used in the pre-fabricated grease duct (item 1). Secure outer access door to outer access door collar using V band (Item 2B); tighten the 1/4-20 hardware to 40-60 in.lbs.

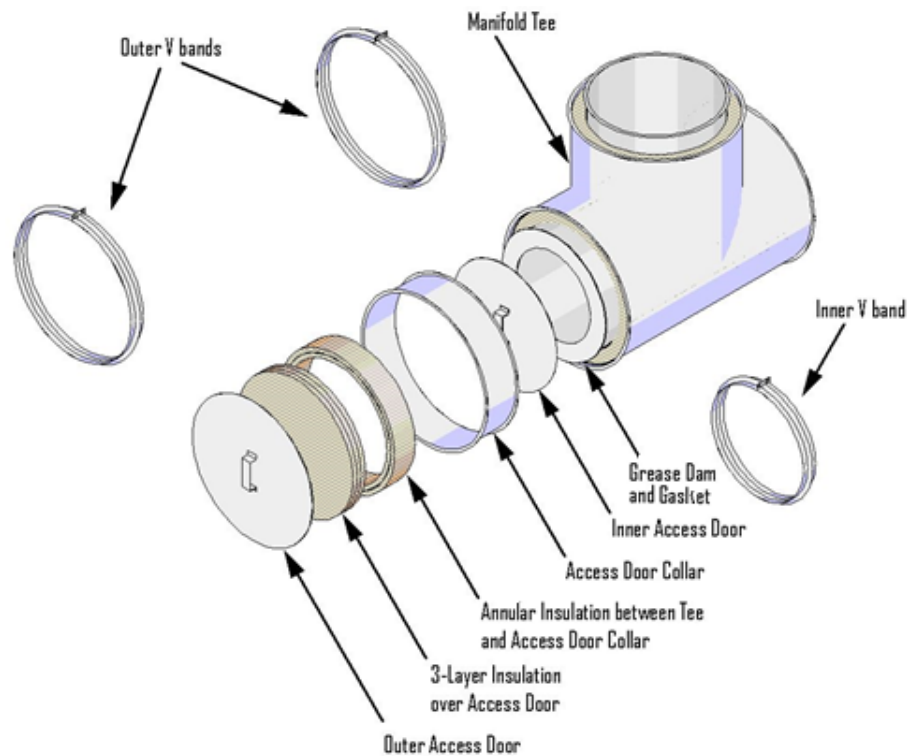

Figure 2. Access Door Assembly



- C. Rigidly support the pre-fabricated grease duct (Item 1) as specified below in Item 3 or in accordance with IMC, NBCC, or NFPA 96 requirements, as applicable, when not specified herein or when those requirements are greater.
- D. Protect the annular space around the pre-fabricated grease duct (Item 1) passing through a fire-rated floor/ceiling assembly or a fire-rated wall assembly as specified in Items 4 and 5, respectively.
- 2. JOINTS:** Join the pre-fabricated grease duct (Item 1) sections using the following components and methods:
- A. **CERTIFIED MANUFACTURER:**  
3M Company
- CERTIFIED PRODUCT:** Sealant
- MODEL:** 3M Fire Barrier™ 2000+
- JOINT SEALANT** – Fill the V band (Item 2B) with a continuous bead of sealant. Apply a continuous 1/4 in. bead of sealant to one of the inner duct flanges to be joined.
- B. **V BAND** – Use the supplied V band (see Figure 1). Place the loose V band, filled with joint sealant (Item 2A), over one of the inner duct flanges. Join to the other inner duct flange with the continuous bead of joint sealant (Item 2A) and rotate slightly to ensure complete coverage of joint sealant (Item 2A) on flanges. Ensure that the flanges are located within the V band and that the V band hardware is not at the bottom side of a horizontal duct. Tap the V band while tightening the integral 1/4-20 hardware to ensure flanges are aligned and pulled together. Tighten to 40-60 in.lbs.
- C. **JOINT INSULATION** – Use the supplied joint insulation, which is a min. of 4-1/2 in. wide, and of the same type, density, and thickness as the insulation used in annular space of the pre-fabricated grease duct (Item 1). Wrap the 4-1/2 in. wide joint insulation around the connection to create three layers of insulation and add a min. 3 in. overlap on the final turn.
- D. **DOUBLE V BAND** – Use the supplied double V band (see Figure 1) for grease duct diameters ≤ 24 in. Place double V band with the grease duct outer shell flanges seated in the V band; tighten integral 1/4-20 hardware to 40-60 in.lbs.
- E. **DOUBLE V CLAMP AND COLLAR** – Use the supplied double V clamp and collar (see Figure 1) for grease duct diameters > 24 in. Use the sheet metal collar to retain the joint insulation; overlap collar ends and fasten together with min. two min. size #6 sheet metal screws. Place double V clamp with the grease duct outer shell flanges seated within the clamp recess; tighten integral 1/4-20 hardware to 40-60 in.lbs.
- 3. SUPPORTS:** Follow the requirements for horizontal supports and vertical penetration supports in Items 3A and 3B, respectively, below.
- A. **HORIZONTAL SUPPORTS** – Support the pre-fabricated grease duct (Item 1) using min. 12 GA, 1-5/8 in. x 1-5/8 in. Unistrut® channel or 2 in. x 2 in. x 1/4 in. steel angle as the supporting cross-member and two min. 1/2 in. diameter, threaded steel rods connected using Grade 5 hex nuts and 1/2 in. hardened washers (see Figure 1, Detail C). For grease duct diameters > 24 in., use supplied 12 GA steel saddles fastened to the Unistrut®



channels with supplied 5/16-18 hardware. Connect the threaded steel rods to the bottom of the floor assembly using an attachment method designed to carry the weight of the pre-fabricated grease duct (Item 1) under a fire load equivalent to ISO 834 time-temperature curve for a 2 hour period. Place one threaded steel rod at each end of the supporting cross-member. Center the pre-fabricated grease duct (Item 1) on the cross-member. Space the threaded steel rods a max. of 8 in. from surface of the pre-fabricated grease duct (Item 1). Cut the cross-members such that each extends a min. 1-1/2 in. past the threaded steel rods. Space horizontal supports a max. of 84 in. on center (oc) for ducts with nominal diameter  $\leq$  16 in., and a max. of 60 in. oc for nominal 18 in. to 36 in. diameter ducts.

- B. VERTICAL PENETRATION SUPPORT – Where the pre-fabricated grease duct (Item 1) penetrates a fire-rated floor/ceiling assembly as specified in Item 4:

- a. Use the support assemblies supplied by the duct manufacturer, made of min. 12 GA steel components, including full support ring (two halves mechanically fastened together), steel angle struts, and steel angle floor brackets. Use supplied 5/16-18 hardware to assemble and fasten components per manufacturer's instructions.
- b. Use 1 in. wide support ring for ducts with nominal diameter  $\leq$  16 in., and use 1-1/2 in. wide support ring for ducts with nominal diameter  $>$  16 in. Position support ring directly under double V band (Item 2D) or double V band clamp and collar (Item 2E).
- c. Use 1-1/2 in. x 1-1/2 in. steel angle struts and floor brackets; use max. 24 in. strut length.
- d. Secure to concrete floor using floor brackets and appropriate type and size concrete anchors, but having min. 3/8 in. diameter and min. 2-1/4 in. length.

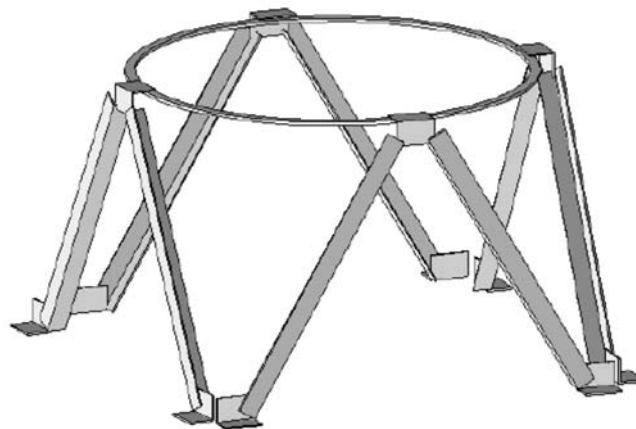

**Figure 3. Vertical Penetration Support**



**4. FLOOR/CEILING PENETRATION FIRESTOP:**

When required to penetrate a fire-rated floor/ceiling assembly, install the firestop system described in Items 4A to 4F (see Figure 4).

A. FLOOR/CEILING ASSEMBLY – Penetrate a 2 hour fire-rated, solid concrete floor/ceiling assembly made from reinforced lightweight or normal weight (100-150 pcf or 1,600-2,400 kg/m<sup>3</sup>) concrete, and having a min. thickness of 4.6 in. Create a square or round opening in the floor/ceiling assembly so that the opening width or diameter is 2 in. to 3 in. greater than the outside diameter of the pre-fabricated grease duct (Item 1). Position the pre-fabricated grease duct (Item 1) concentrically or eccentrically in the opening so that the annular space ranges from min. 1 in. to max. 2 in. For a square opening, measure the annular space normal to both the duct wall and the nearest vertical face of the floor opening.

B. CLOSURE PLATES – Use the two supplied closure plates, constructed of min. 18 GA steel and cut to fit around the duct with a min. 1 in. plate-on-plate overlap and a 3 in. min. overlap onto the bottom of the floor/ceiling assembly (Item 4A). Apply a continuous 1/2 in. bead of fill, void, or cavity material (Item 4D) around the perimeter of the closure plates. Push the plates up against the bottom of the floor/ceiling assembly (Item 4A) such that the applied fill, void, or cavity material (Item 4D) seals against the floor/ceiling assembly (Item 4A). Secure the closure plates to the floor/ceiling assembly (Item 4A) using 1/4-20 x 1-1/2 in. long concrete fasteners spaced max. 9-1/2 in. oc. Fasten the closure plates to each other at the overlap using 1/4-20 x 1 in. long metal screws, two on each side. Apply a 1 in.

bead of fill, void, or cavity material (Item 4D) to the top side of the closure plates along perimeter of opening in the floor/ceiling assembly (Item 4A) and around the pre-fabricated grease duct (Item 1).

C. PACKING MATERIAL – Fill the annular space between the pre-fabricated grease duct (Item 1) and the floor/ceiling assembly (Item 4A) with insulation supplied by the duct manufacturer, which is nominal 1 in. thick, and of the same type and density as the annular insulation used in pre-fabricated grease duct (Item 1). Install a min. of four horizontal layers in the annular space; compress min. 33% of actual insulation thickness such that the insulation is recessed 3/4 in. from top of floor/ceiling assembly (Item 4A). Fill the entire annular space with the exception of the required recess.

D. MANUFACTURER:  
Specified Technologies, Inc.

LISTED PRODUCT: Sealant

MODEL: SpecSeal® Series SSS

FILL, VOID, OR CAVITY MATERIAL – Apply min. 3/4 in. depth of fill material into the recess over the packing material (Item 4C). Make fill material flush with the top surface of the floor. Overlap the fill material onto the pre-fabricated grease duct (Item 1) a min. of 1 in. and onto the floor/ceiling assembly (Item 4A) a min. of 3 in.

E. INSULATION COLLAR AND ENCLOSURE BANDS – After the fill, void, or cavity material (Item 4D) has cured enough to "skin over," wrap one layer of insulation to form a collar around the base of the duct on the top side of the floor/ceiling



assembly (Item 4A). Use insulation supplied by the duct manufacturer that is nominal 1 in. thick, and of the same type as the annular insulation used in the pre-fabricated grease duct (Item 1). Enclose the insulation collar with the two manufacturer-supplied 12 in. tall, half enclosure bands, which are constructed of stainless steel and are equipped with 1/4-20 x 3/4 in. long hardware to secure the enclosure bands together. Ensure that the insulation collar and enclosure bands are in contact with the fill, void, or cavity material (Item 4D), and ensure that the fill, void, or cavity material (Item 4D)

seal is not broken or otherwise compromised.

- F. SUPPORT – Install the vertical penetration support (Item 3B), with full support ring installed directly under the double V band (Item 2D) or double V band clamp and collar (Item 2E).

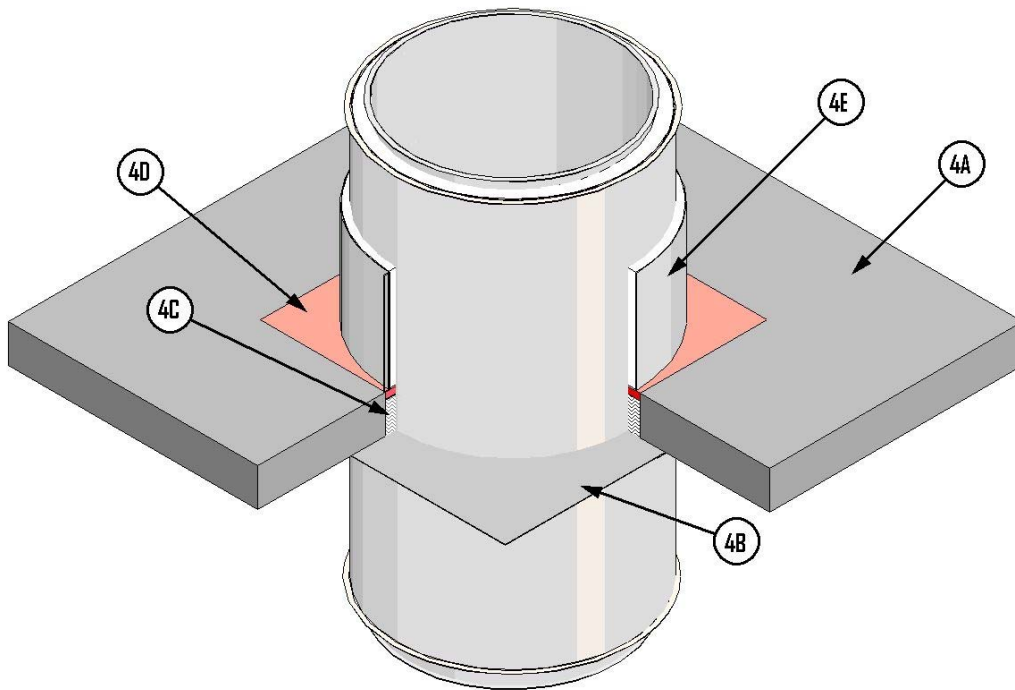

**Figure 4: Floor/Ceiling Firestop**

**5. WALL PENETRATION FIRESTOP:** When required to penetrate a fire-rated wall assembly, install the firestop system described in Items 5A to 5F (see Figure 5).

- A. WALL ASSEMBLY – Penetrate a 2 hour fire-rated, solid concrete wall assembly made from reinforced lightweight or normal

weight (100-150 pcf or 1,600-2,400 kg/m<sup>3</sup>) concrete, and having a min. thickness of 4.6 in. Create a square or round opening in the wall assembly so that the opening width or diameter is 2 in. to 3 in. greater than the outside diameter of the pre-fabricated grease duct (Item 1). Position the pre-



fabricated grease duct (Item 1) concentrically or eccentrically in the opening so that the annular space ranges from min. 1 in. to max. 2 in. For a square opening measure the annular space normal to both the pre-fabricated grease duct (Item 1) wall and the nearest horizontal face of the wall opening.

- B. CLOSURE PLATES – Use two supplied closure plates per side of wall assembly (Item 5A); closure plates constructed of min. 18 GA steel and cut to fit around the duct with a min. 1 in. plate-on-plate overlap and a 3 in. min. overlap onto the wall assembly (Item 5A). Apply a continuous 1/2 in. bead of fill, void, or cavity material (Item 5C) around the perimeter of two closure plates. Press the first set of closure plates against one side of the wall assembly (Item 5A) such that the applied fill, void, or cavity material (Item 5C) seals against the wall assembly (Item 5A). Secure the first set of closure plates to the wall assembly (Item 5A) using 1/4-20 x 1-1/2 in. long concrete fasteners spaced max. 9-1/2 in. oc. Fasten the first set of closure plates to each other at the overlap using 1/4-20 x 1 in. long metal screws, two on each side. Install the other two closure plates on the opposite side of the wall after installing the fill, void, or cavity material (Item 5C) and the packing material (Item 5D) as described in Items 5C and 5D. Follow the same procedure used for the first set of closure plates, except exclude the bead of fill, void, or cavity material (Item 5C) on the perimeter of the second set of closure plates.

- C. MANUFACTURER:  
Specified Technologies, Inc.

LISTED PRODUCT: Sealant

MODEL: SpecSeal® Series SSS

FILL, VOID OR CAVITY MATERIAL – Apply min. 3/4 in. thick layer of fill material onto the first set of closure plates (Item 5B) within the annular space created between the pre-fabricated grease duct (Item 1) and the wall assembly (Item 5B). Install packing material (Item 5D) into the annular space as described in Item 5D. Install a min. 3/4 in. thick layer of fill, void, or cavity material into the recess in the annular space. Install fill, void, or cavity material flush with the face of the wall assembly (Item 5A). Overlap the fill material onto the pre-fabricated grease duct (Item 1) a min. of 1 in. and onto the face of the wall assembly (Item 5A) a min. of 3 in.

- D. PACKING MATERIAL – Fill the annular space between the pre-fabricated grease duct (Item 1) and the wall assembly (Item 5A) with insulation supplied by the duct manufacturer, which is nominal 1 in. thick and of the same type and density as the annular insulation used in pre-fabricated grease duct (Item 1). Install a min. of four vertical layers in the annular space; compress min. 33% of actual insulation thickness such that the insulation is recessed 3/4 in. from the face of the wall assembly (Item 5A). Fill the entire annular space with the exception of required recess.

- E. INSULATION COLLAR AND ENCLOSURE BANDS – Wrap one layer of insulation to form a collar around the base of the duct on each side of the wall assembly (Item 5A). Use insulation supplied by the duct manufacturer that is nominal 1 in. thick and of the same type as the annular insulation used in the pre-fabricated grease duct (Item 1). Enclose each of the insulation collars with two



manufacturer-supplied 12 in. tall, half enclosure bands, which are constructed of stainless steel and are equipped with 1/4-20 x 3/4 in. long hardware to secure the enclosure bands together. Ensure that the insulation collars and enclosure bands are in contact with the fill, void, or cavity

material (Item 5C) on each side of the wall assembly (Item 5A).

- F. SUPPORT – Install the horizontal supports (Item 3A) on each side of the wall assembly (Item 5A).

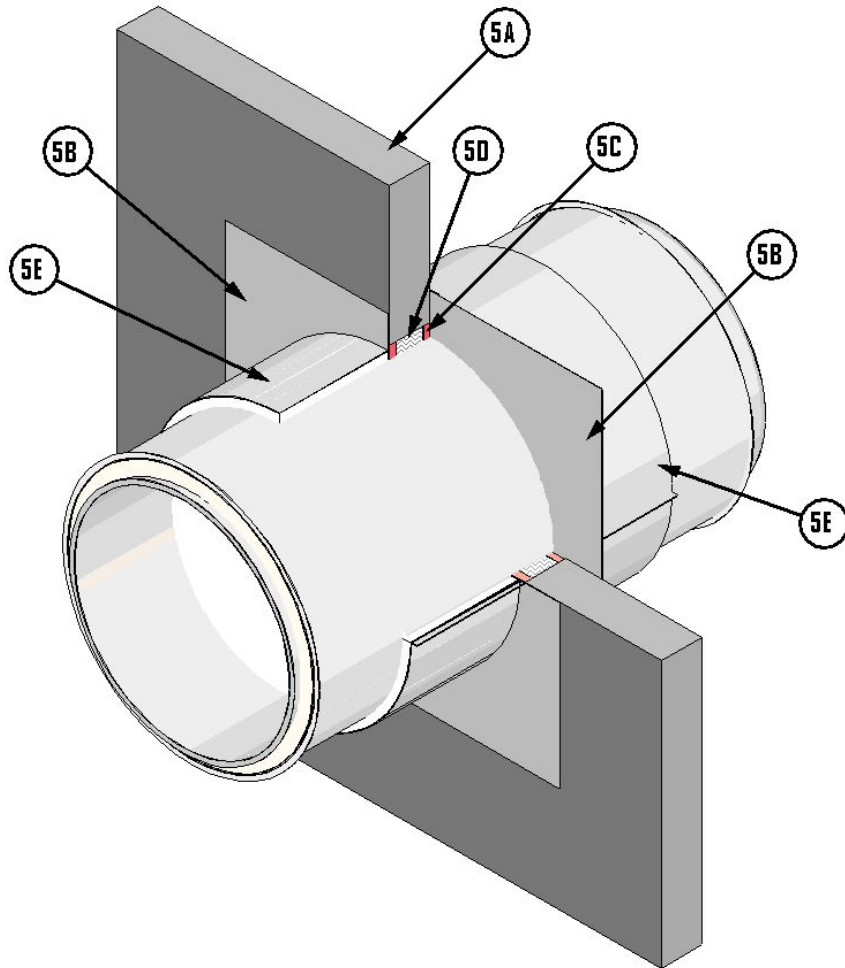

**Figure 5. Wall Firestop**

Consult the listing report on the Directory of Building Products (<https://bpdirectory.intertek.com>) for the edition of the standard(s) evaluated.