

DESIGN NO. TRC/PV 180-01
VERTICAL (WALL), F RATING - 3 HRS, T RATING - 15 MINUTES;
ANNULAR SPACING - 0 TO 3-1/4"
TEST PRESSURE DIFFERENTIAL - 2.5 Pa (0.01" OF WATER) MINIMUM

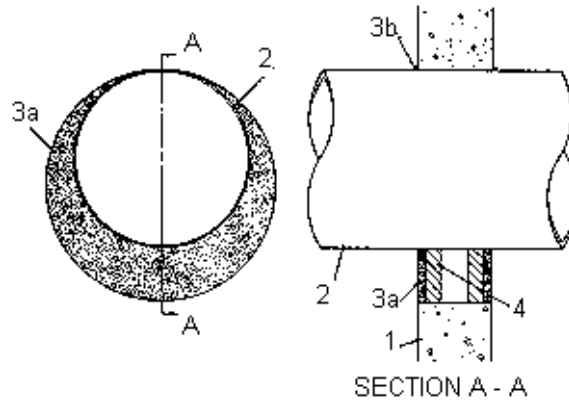

Manufacturer's Designation: 950 CW-10.

1. Wall: Nominal 4-1/2" thick or thicker solid concrete wall with a 17" diameter opening.
2. Penetrations: 1) 10" I.D. Steel Pipe - Schedule 10S.
3. Caulking Compound or Filler Material:
 - a) 1/2" Metalines, Inc. Metacaulk* 950 each side of partition.
 - b) Metalines, Inc. Metacaulk* 950 Bead. Put a bead of Metacaulk* 950 around pipe perimeter where there is no annuli.
4. Insulation: Foam Backing Material.

*Component bearing the Warnock Hersey Certification Mark