

Design Number RBL/SFWT 90-01
REDBUILT OPEN-WEB TRUSS & RED-I JOIST SERIES

RedBuilt LLC
ASTM E119 and CAN/ULC S101
Load Bearing Fire Resistance Rated Roof/Ceiling, Floor/Ceiling Assembly
90-Minute Rating

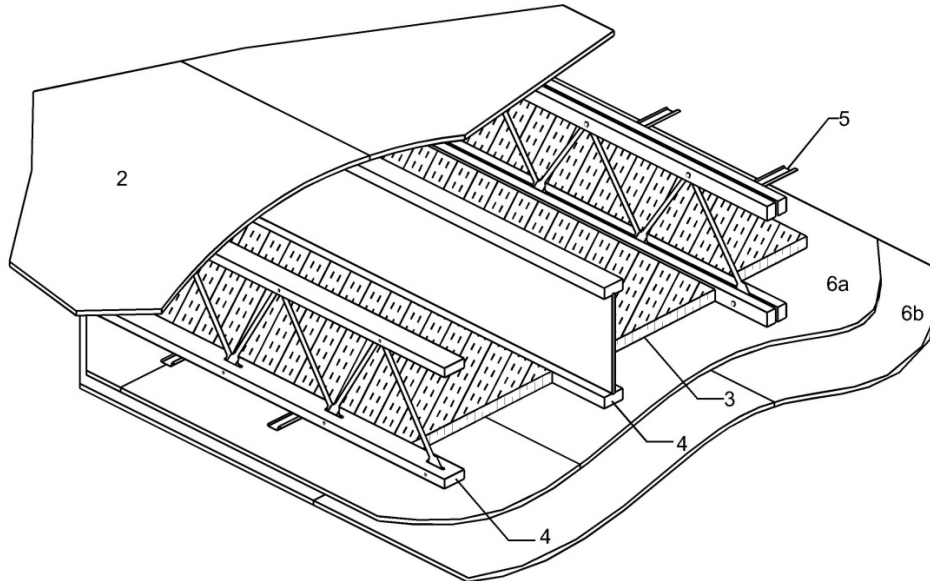

1. FLOOR TOPPING (Optional, not shown): Gypsum concrete, lightweight or normal concrete topping. When used as a roof assembly, materials for a built-up roof covering that are described in an assembly that provides a Class A, B, or C rating on combustible wood decks may be used.

2. FLOOR SHEATHING: Min. 5/8 in. thick wood sheathing, installed per code requirements. When used as a roof assembly, min. 1/2 in. thick wood sheathing may be used, installed per code requirements.

3. INSULATION: Min. 1-1/2 in. thick mineral wool insulation batts – 2.5 pcf (min.). Batt installed on top of resilient channels with the sides butted against the sides of the joists. The ends of the batts shall be centered over resilient channels and tightly butted.

4. CERTIFIED COMPANY: RedBuilt LLC

CERTIFIED PRODUCT: Shop fabricated wood trusses

CERTIFIED MODELS:

RED-I JOIST SERIES: RED-I65, RED-I90, RED-I90H and RED-I90HS.

OPEN-WEB TRUSS SERIES: RED-L, RED-W, RED-S, RED-M and RED-H.

9-1/4 in. min. deep joists spaced a max. of 24 in. on center (oc) (Min. 1-1/2 in. by 2 5/16 in. flange dimensions). Installed in accordance with the Code.

5. RESILIENT CHANNELS: Min. 0.019 in. thick galvanized steel resilient channels, attached perpendicular to joists using 1-5/8

in. long drywall screws. Resilient channels spaced a max. of 12 in. oc.

6. GYPSUM WALLBOARD: Two layers of min. 5/8 in. thick Type C gypsum wallboard as follows:

6a. Wallboard Base Layer: Base layer of wallboard attached to resilient channels using 1-1/4 in. type S drywall screws at 12 in. oc. Edge joints shall be centered between joists. End joints shall be staggered a min. of one channel spacing.

6b. Wallboard Face Layer: Face layer of wallboard attached to resilient channels through base layer using 1-5/8 in. Type S drywall screws spaced 12 in. oc, 6 in. oc at wallboard end joints, and 3/4 in. from panel edges and ends. Edge joints of wallboard face layer offset a min. distance equal to one joist spacing from those of base layer. End joints shall be offset from base layer joints by a min. of one channel spacing and shall be centered in-between channel spacing. Additionally, wallboard face layer attached to base layer with 1-1/2 in. Type G drywall screws spaced 8 in. oc, placed 1-1/2 in. from face layer end joints.

7. FINISH SYSTEM (Not shown): Face layer joints covered with tape and coated with joint compound. Screw heads covered with joint compound.