

Simpson Strong-Tie Co., Inc.
Design No. SST/WPCF 120-01

Fire Resistant Joist Hanger

DGF, DGBF, DGHF, DGT, DGHT, DU, DHU, DHUTF, HHGU, LGU, MGU, HGU, and HUCQ Fire Wall Hanger

ASTM E814

Rating (DGF, DGBF, DGHF, DU, DHU, DHUTF, HHGU, LGU, MGU, HGU, and HUCQ): 2 Hour F Rating; 2 Hour T Rating

Rating (DGT and DGHT): 2 Hour F Rating; 1-1/4 Hour T Rating

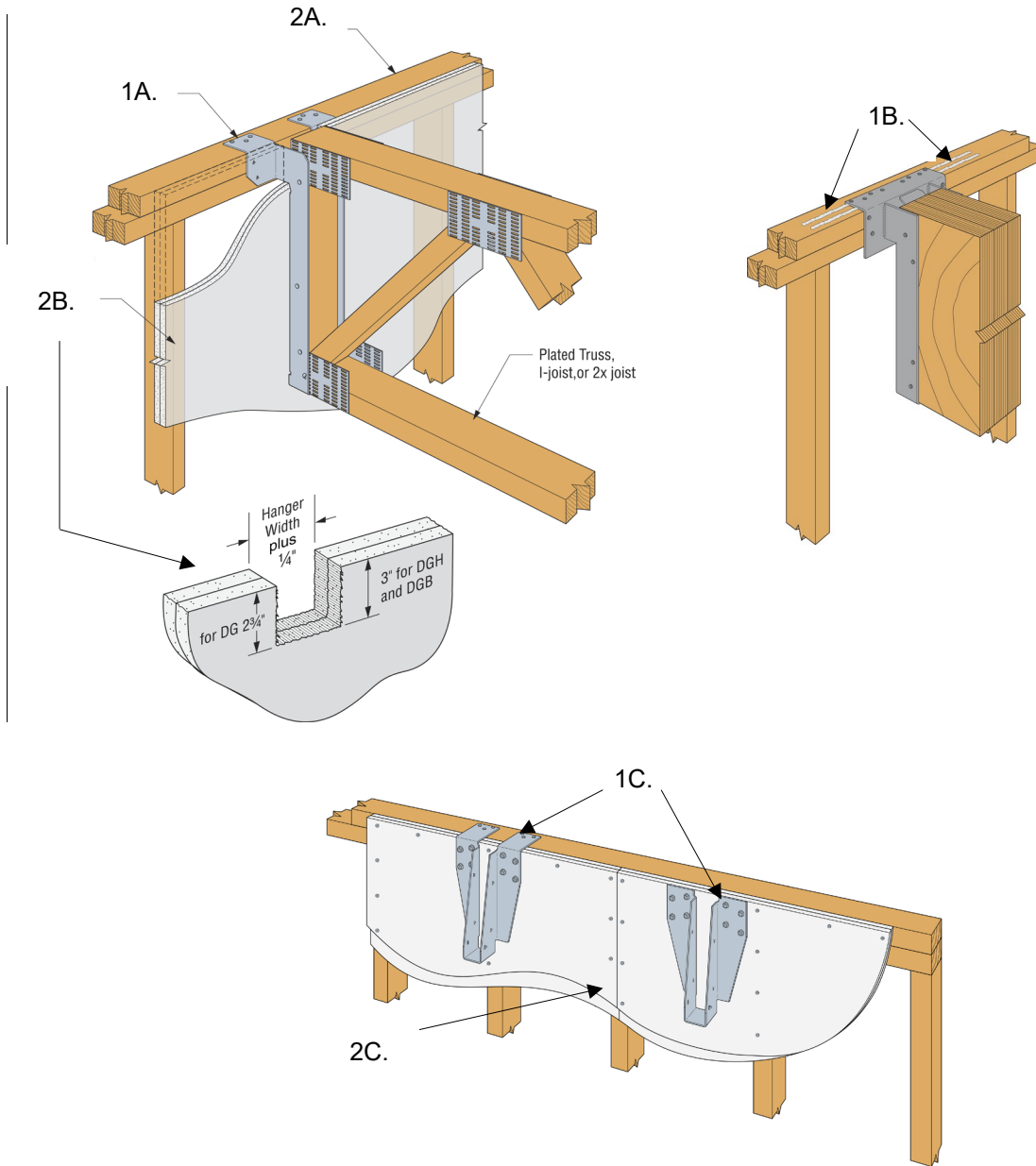



Division 06 – Wood, Plastics, and Composites
06 05 00 Common Work Results for Wood, Plastics, and Composites
06 05 23 Wood, Plastic, and Composite Fastenings

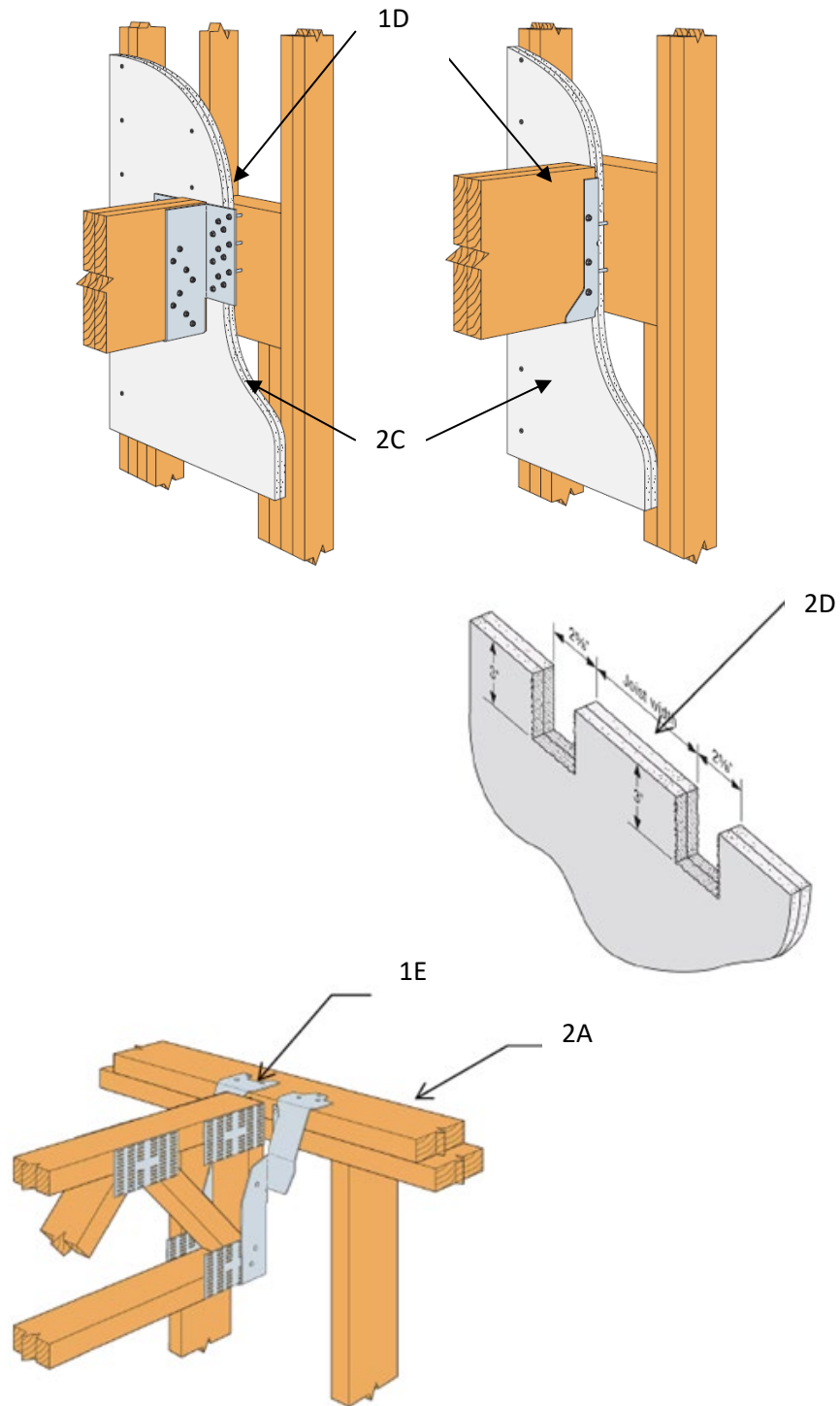



1. FIRE WALL HANGERS:

CERTIFIED PRODUCT: Simpson Strong-Tie Co., Inc. DGF, DGBF, DGHF, DGT, DGHT, DU, DHU, DHUTF, HHGU, LGU, MGU, HGU, and HUCQ Fire Wall Hangers

The DG Series features enough space for drywall to be installed before the hanger. The DU Series are installed after drywall. The hangers may be installed in back-to-back construction on min. nominal 2 × 6 wood stud wall, max. 16 in. on center (oc) stud spacing.

- A. Attach the DGF Series Fire Wall Hanger directly to the top wall plates with min. 0.148 in. diameter (min. 1-1/2, max. 3 in. length) nails.
- B. With the DGBF, apply two 1/4 in. beads of fire-resistant mortar caulk, 6 in. long and directly to the top wall plates.
- C. For DU series hangers, gypsum shall be installed first, then mount the DU and DHU with top of hanger flush with top of wall and tight to drywall. Install DHUTF with top flange to top of wall. All DU series hangers shall be attached through the face with SDS 3-1/2 in. × 1/4 in. screws. Attach DHUTF hanger top flange with 10d × 1-1/2 in. nails.

- D. For HHGU, LGU, MGU, HGU, and HUCQ series hangers, gypsum shall be installed first. Hanger shall be attached through the face with number of fasteners per structural ratings.
- E. Attach DGT and DGHT Fire Wall Hanger directly to the top plates with 0.148 diameter min. 1-1/2 in., max. 2-1/2 in. length nails.

2. WOOD FRAMED 2 HOUR FIRE-RATED WALL:

- A. Min. nominal 2 × 4 wood stud wall, max. 16 in. oc stud spacing.
- B. Two layers of 5/8 in., Type X, gypsum installed per Code for 2 hour rated wall. Both layers of drywall shall be notched 1/4 in. wider than the Fire Wall Hanger width, 2-3/4 in. height for the DGF, and 3 in. height for the DGBF and DGHF.
- C. Two layers of 5/8 in., Type X, gypsum installed per Code for 2 hour rated wall for DU, HHGU, LGU, MGU, HGU, and HUCQ series face mounted hanger installation.
- D. Two layers of 5/8 in., Type X, gypsum installed per Code for 2 hour rated wall. Both layers of drywall shall be notched each side of the hanger 2-5/8 in. width, 3 in. height for DGT and DGHT

Consult the listing report on the Directory of Building Products (<https://bpdirectory.intertek.com>) for the edition of the standard(s) evaluated.



Division 06 – Wood, Plastics, and Composites
06 05 00 Common Work Results for Wood, Plastics, and Composites
06 05 23 Wood, Plastic, and Composite Fastenings

Compliance of the assembly described in this Design Listing with the referenced standard relies on verification that the assembly constructed in the field is consistent with that described herein. Intertek certified products may be verified by the approved Intertek label; other products must be verified by the Authority Having Jurisdiction as meeting the specifications stated herein.