

SAFTI FIRST
SF/WA 45-02
EZ Framing with SAFTI FIRST Glazing
UL9 (2009), NFPA 257 (2007)
45 Minutes w/o Hose

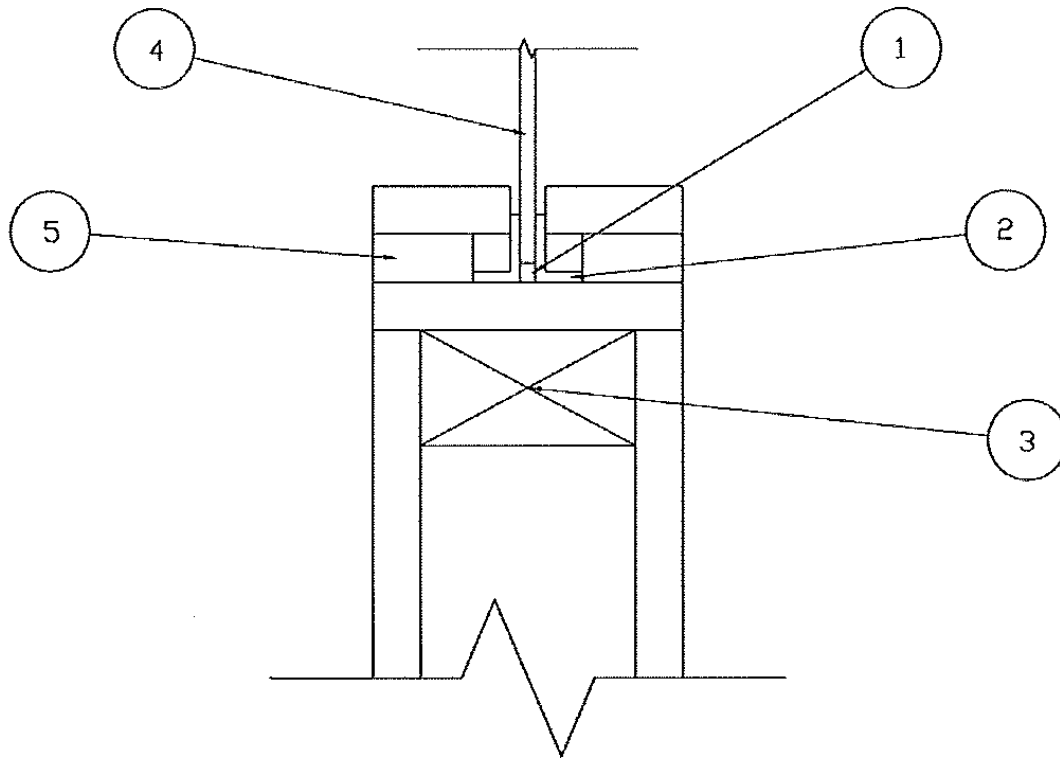

1. CERTIFIED MANUFACTURER: SAFTI FIRST

CERTIFIED PRODUCT: SAFTI FIRST EZ Framing Assembly with SAFTI FIRST Glazing

Glazing that can be used is SuperLite I-XL, -IGU & II-ML 45. The glazing is attached to the gypsum wallboard using 5/8" x 5/8" x 16 gauge steel angles. Stop height is optional as 3/8" or 5/8". 5/8" stop height must be used for approved sizes of Superlite I-XL & -IGU. 3/8" stop height restricted to 96" wide x 60" high glazing. One layer of 5/8" gypsum wallboard to be placed through opening. Wall construction is to be listed and rated gypsum wall assembly. Anchorage shall be every 8" on center.

2. Components:

1. Setting Block (Non-Combustible)
2. 5/8" x 5/8" x 16 Gauge Steel Angles(stop height from top of setting block 5/8" or 3/8" as noted in certified product info 1. above)
3. Rated Gypsum Wall Design
4. SuperLite I-XL, -IGU or II-ML 45
5. 5/8" Gypsum Wallboard Decorative Finish (Optional)
6. 1/8" x 1/2" Glazing Tape (Not Shown)