

ClarkDietrich®
Design No. CD/WA 120-02
Non-Load Bearing Stairwall Assembly
ASTM E119 and CAN/ULC S101
Fire-Resistance Rating: 2 Hour
Design Weight: 8.5 psf

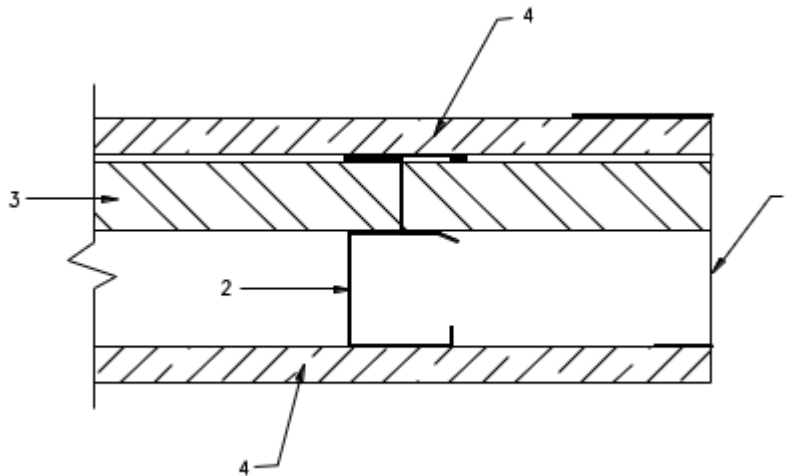

STC Rating, As Shown Above: 39

STC Rating: As Shown Above with 1-1/2 in. thick 3 pcf mineral fiber insulation in cavity: 43

1. FLOOR, CEILING, CORNER, AND INTERSECTION TRACKS*:

J-Tabbed Track with unequal legs, 2-1/2 in. min. deep, fabricated from min. 0.019 in. thick galvanized steel. Position Tracks with short leg towards cavity side of wall. Tracks attached to structural members with steel fasteners located not greater than 24 in. on center (oc). J-Tabbed Tracks have tab at 12 in. oc and are manufactured by ClarkDietrich.

2. STEEL STUDS*:

'C-T' shaped slotted web studs, 1-1/2 in. wide × 2-1/2 in. min. deep, fabricated from min. 0.019 in. thick galvanized steel. Cut to length 1/2 in. less than the opening's height and spaced 24 in. max. oc and between 1 in. thick gypsum shaftliner panels. Studs are manufactured by ClarkDietrich.

3. GYPSUM SHAFTLINER:

1 in. thick CertainTeed M2Tech Shaftliner Type X gypsum board (complying with ASTM C1396), or 1 in. thick

Continental™ Shaftliner Type X*, or Mold Defense® Shaftliner Type X* drywall, or 1 in. Weather Defense® Platinum Shaftliner Type X* drywall (complying with ASTM C1396), or 1 in. thick Georgia-Pacific ToughRock® Shaftliner* (complying with ASTM C1396 as Type X), or 1 in. thick DensGlass® Shaftliner* (complying with ASTM C1658 as Type X), or 1 in. thick National Gypsum Gold Bond® Fire Shield® Shaftliner (complying with ASTM C1396), or USG Sheetrock® Gypsum Liner Panel (complying with ASTM C1396 for Type X), supplied in nominal 24 in. widths. The panels are inserted against the long leg of the J-Tabbed Track and into the 1 in. deep recess of the studs. Free edges of end panels are retained by bending J-Tabbed Track tabs (12 in. oc) at a 90° angle.

4. GYPSUM BOARD:

1/2 in. thick CertainTeed Type C proprietary core gypsum board, or 5/8 in. thick Type X gypsum board (complying with ASTM



C1396), or 1/2 in. thick Continental Firecheck® proprietary core Type C drywall, or 5/8 in. thick Firecheck® Type X drywall (complying with ASTM C1396), or 1/2 in. thick Georgia-Pacific ToughRock® Fireguard C® proprietary core gypsum board, or 1/2 in. thick DensArmor Plus Fireguard C® proprietary core gypsum board (complying with ASTM C1658 for Type X), or 5/8 in. thick ToughRock® Fireguard X® gypsum board (complying with ASTM C1396), or 1/2 in. thick National Gypsum Gold Bond® Fire Shield® C proprietary core gypsum board, or 5/8 in. thick Fire Shield® gypsum board (complying with ASTM C1396 for Type X), or 1/2 in. thick USG Sheetrock® Firecode® C proprietary core gypsum board, or 5/8 in. thick Sheetrock® Firecode X gypsum board (complying with ASTM C1396), applied vertically to both sides of the studs with

joints offset and attached with min. 1 in. long drywall screws 12 in. oc, starting 6 in. from the top and bottom.

Face layer gypsum board joints are finished with paper tape and joint compound (complying with ASTM C475). Exposed screw heads are finished with joint compound (complying with ASTM C475).

Limitations: Gypsum Shaftliner and Gypsum Board must be by the same manufacturer.

*Component bearing the Warnock Hersey Certification Mark, manufacturing information of these components is proprietary to the listed component's manufacturer.

Consult the listing report on the Directory of Building Products (<https://bpdirectory.intertek.com>) for the edition of the standard(s) evaluated.

Compliance of the assembly described in this Design Listing with the referenced standard relies on verification that the assembly constructed in the field is consistent with that described herein. Intertek certified products may be verified by the approved Intertek label; other products must be verified by the Authority Having Jurisdiction as meeting the specifications stated herein.