

Specified Technologies, Inc.
Design No. STI/BPF 120-32
Perimeter Fire Barrier System
SpecSeal® AS Elastomeric Spray
ASTM E2307, CAN/ULC-S115
Ratings: F-Rating – 2 Hour, T-Rating – 1/2 Hour
UL 2079 Air Leakage
L-Rating <2 SCFM/LF
Rated for ± 0% movement

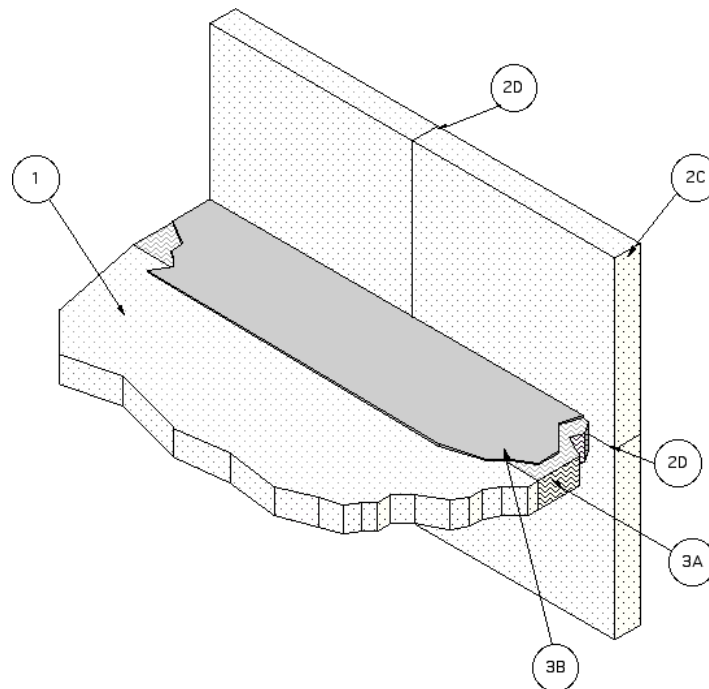

1. CONCRETE FLOOR ASSEMBLY: Two-hour rated concrete floor assembly made from either lightweight or normal weight concrete with a density of 100-150 pcf, with a min. thickness of 4-1/2-in. at the joint face. Overall slab thickness may vary to accommodate various blockout depths (longitudinal recesses) formed in the concrete, to house the architectural cover plate.

The blockout width may also vary without restriction.

2. CURTAIN WALL ASSEMBLY: The concrete tilt-up curtain wall assembly shall incorporate the following construction features:

A. **PANEL MOUNTING ATTACHMENT** (Not shown) Attachment of the concrete tilt-up



wall panels to the structural framing shall be according to the curtain wall manufacturer's instructions. When required, mounting attachments to the floor slab shall be connected to the joint face of the floor slab, according to the curtain wall manufacturer's instructions. Max. distance between mounting attachments shall be 10 feet.

- B. **Structural Framing:** (Not shown) Structural framing members shall be according to the curtain wall system manufacturer's requirements. Aluminum structural framing must be completely covered by concrete panels.
- C. **Tilt-up Panels:** Tilt-up concrete wall panels, min. 2-1/2 in. thick, reinforced lightweight or normal weight (100 – 150 pcf). Install panels to structural framing according to the curtain wall system manufacturer's requirements.
- D. **Concrete Panel Joint:** Vertical and horizontal concrete panel butt joints can be either flush type (butt joint) or key way type (tongue and groove). Concrete panel edges at butt joints must be in contact with each other. If required, the surface of the panel joints can be sealed with gaskets or sealants.
- E. **Curtain Wall Insulation:** (Optional) When curtain wall insulation is used, the perimeter joint treatment must be installed before the insulation. Insulation may be butted to top and bottom of perimeter joint treatment but not deform the perimeter joint treatment. Either mineral wool or fiberglass batt insulation may be used.

- F. **Impaling Pins:** (Not shown) When curtain wall insulation is used, use impaling pins when required by manufacturer's instructions. The pins shall be located, sized and installed according to the curtain wall system manufacturer's guidelines.

3. PERIMETER JOINT PROTECTION: The perimeter joint (linear opening) shall not exceed an 8 in. nom. joint width (joint width at installation) and the perimeter joint treatment shall incorporate the following construction features:

- A. **CERTIFIED PRODUCT:** Thermafiber® Safing

PACKING MATERIAL – Use a min. 4 in. thick, 4 pcf density, mineral wool batt insulation installed with the fibers running parallel to the slab edge and curtain wall. The packing material shall be compressed 50% in the nominal joint width. Compress the batt insulation into the perimeter joint such that the top surface of the batt insulation is flush with the top surface of the concrete floor slab. Splices (butt joints) in the lengths of mineral wool batt insulation are to be tightly compressed together.

- B. **CERTIFIED PRODUCT:** Specified Technologies, Inc. SpecSeal® AS Elastomeric Spray (Cat No. AS205 and AS205R)

FILL, VOID, OR CAVITY MATERIAL – Liquid is to be spray applied to cover the exposed surface of the mineral wool installed in the perimeter joint. Apply a min. wet film thickness of 1/8 in. and overlap the material a min. 1/2 in. onto the adjacent curtain wall assembly and concrete floor slab assembly. If the spraying process is stopped and the applied liquid cures to an elastomeric film before process is restarted, then overlap the edge of the cured material at least 1/8



in. with the spray. Reference Product Section of this Directory for more details about the Listed product.

- C. Support Clips: (Not Shown) Support clips are optional but recommended for installations subject to vertical shear movement.

Standard Z-shaped clips are 20 GA galvanized steel with the following dimensions: 1 in. wide by 3 in. high with a 2 in. upper leg and 3 in. lower leg.

Consult the listing report on the Directory of Building Products (<https://bpdirectory.intertek.com>) for the edition of the standard(s) evaluated.

Compliance of the assembly described in this Design Listing with the referenced standard relies on verification that the assembly constructed in the field is consistent with that described herein. Intertek certified products may be verified by the approved Intertek label; other products must be verified by the Authority Having Jurisdiction as meeting the specifications stated herein.