

Specified Technologies, Inc.
Design No. STI/BPF 120-35
Perimeter Fire Barrier System
SpecSeal® AS Elastomeric Spray
ASTM E2307, CAN/ULC-S115
Ratings: F-Rating – 2 Hour, T-Rating – 1/2 Hour
UL 2079 Air Leakage
L-Rating <2 SCFM/LF
ASTM E 1399 Class IV
Rated for ± 16.7% Horizontal Movement

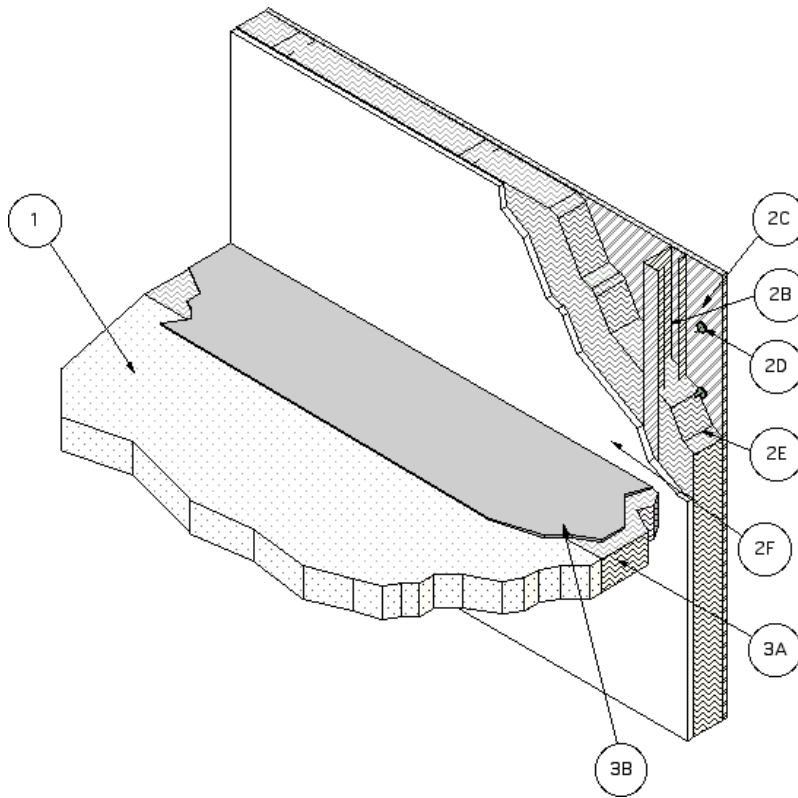

- 1. CONCRETE FLOOR ASSEMBLY:** Two-hour rated concrete floor assembly made from either lightweight or normal weight concrete with a density of 100-150 pcf, with a min. thickness of 4-1/2-in. at the joint face. Overall slab thickness may vary to accommodate various blockout depths (longitudinal recesses) formed in the concrete, to house the architectural cover plate.

The blockout width may also vary without restriction.

- 2. CURTAIN WALL ASSEMBLY:** The curtain wall assembly shall incorporate the following construction features:



- A. **PANEL MOUNTING ATTACHMENT** (Not shown) Attachment of the curtain wall framing to the structural framing shall be according to the curtain wall manufacturer's instructions. When required, the mounting attachments to the floor slab shall be connected to the joint face of the floor slab, according to the curtain wall manufacturer's instructions. Max. distance between mounting attachments shall be 10 feet.
- B. **Steel-Stud Framing:** Vertical framing members shall be min. 3-5/8 in. by 1-5/8 in., 18 GA steel "C" studs. Attachment shall be according to the curtain wall system manufacturer's guidelines. Vertical framing shall not exceed a spacing of 48 in. o.c. If required, horizontal framing members shall be installed according to the curtain wall system manufacturer's guidelines.
- C. **Steel Panels:** Steel panels shall be attached to curtain wall framing according to the curtain wall system manufacturer's guidelines. Use a min. 20 GA sheet steel panel with max. dimensions of 48 in. by 144 in.
- D. **Impaling Pins: (Not Shown)** When used with insulation and framing covers, the pins shall be located, sized and installed according to the curtain wall system manufacturer's guidelines, or be a min. 4-1/2 in. long, 12 GA steel pin attached to a nom. 2 in. by 2 in. galvanized sheet steel plate, a nom. 2 in. by 2 in. by 2 in. long angle, or directly attached to steel panel using a stud gun. Pins shall be spaced a max. of 12 in. o.c. and installed around the periphery (min.) so that the

interior face of the curtain wall insulation is flush with the interior face of the framing.

- E. **CERTIFIED PRODUCT:** Rockwool Roxul CurtainRock® 40 or CurtainRock® 80

Curtain Wall Insulation: A nom. 4 pcf mineral wool batt insulation faced on one side with aluminum foil scrim (vapor retarder) which is exposed to the room interior and installed the full depth of the stud cavity. Batts are fitted tightly between vertical framing members, secured with clips, impaling pins, or friction fit using a batt insulation length at least 1/4 in. longer than the distance between vertical framing members. All meeting edges of insulation are sealed with nom. 4-in. wide pressure sensitive aluminum foil faced tape centered over the junction so that approx. 2 in. of tape covers each edge of the adjacent insulation. The nom. 4-in. wide pressure sensitive aluminum foil faced tape is applied over all meeting edges of insulation and framing members so that approx. 2 in. of tape covers each edge of the adjacent material. In lieu of filling the full depth of the stud cavity with 4 pcf mineral wool, the use of 2 in., 8 pcf mineral wool is allowed but may not be secured by friction fit and must have a horizontal support angle installed at the mid depth of the perimeter joint protection and mechanically attached to all vertical framing. The interior face of the batts is compressed flush with the interior face of the curtain wall framing. The 24 in. wide batts shall be installed without vertical seams, spanning the full length between the vertical curtain wall framing members. Batt insulation shall fill the cavity of all "C"-shaped studs. Horizontal seams in the insulation are to be at least 6 in. from the



top surface of the perimeter joint treatment.

3. PERIMETER JOINT PROTECTION: The perimeter joint (linear opening) shall not exceed an 8 in. nom. joint width (joint width at installation) and the perimeter joint treatment shall incorporate the following construction features:

A. **CERTIFIED PRODUCT:** Rockwool Roxul Safe®

PACKING MATERIAL – Use a min. 4 in. thick, 4 pcf density, mineral wool batt insulation installed with the fibers running parallel to the slab edge and curtain wall. The packing material shall be compressed 50% in the nominal joint width. Compress the batt insulation into the perimeter joint such that the top surface of the batt insulation is flush with the top surface of the concrete floor slab. Splices (butt joints) in the lengths of mineral wool batt insulation are to be tightly compressed together.

B. **CERTIFIED PRODUCT:** Specified Technologies, Inc. SpecSeal® AS Elastomeric Spray (Cat No. AS205 and AS205R)

FILL, VOID, OR CAVITY MATERIAL – Liquid is to be spray applied to cover the exposed surface of the mineral wool installed in the perimeter joint. Apply a min. wet film thickness of 1/8 in. and overlap the material a min. 1/2 in. onto the adjacent curtain wall assembly and concrete floor slab assembly. If the spraying process is stopped and the applied liquid cures to an elastomeric film before process is restarted, then overlap the edge of the cured material at least 1/8 in. with the spray. Reference Product Section of this Directory for more details about the Listed product.

C. **Support Clips:** (Not Shown) Support clips are optional but recommended for installations subject to vertical shear movement. Standard Z-shaped clips are 20 GA galvanized steel with the following dimensions: 1 in. wide by 3 in. high with a 2 in. upper leg and 3 in. lower leg.

Consult the listing report on the Directory of Building Products (<https://bpdirectory.intertek.com>) for the edition of the standard(s) evaluated.

Compliance of the assembly described in this Design Listing with the referenced standard relies on verification that the assembly constructed in the field is consistent with that described herein. Intertek certified products may be verified by the approved Intertek label; other products must be verified by the Authority Having Jurisdiction as meeting the specifications stated herein.