

**Specified Technologies, Inc.**  
**Design No. STI/BPF 90-06**  
**Perimeter Fire Barrier System – Window Wall Assembly**  
**SpecSeal® Window Wall Gasket**  
**ASTM E2307, CAN/ULC-S115**  
**Ratings: F-Rating – 1-1/2 Hour, T-Rating – 1-1/4 Hour**

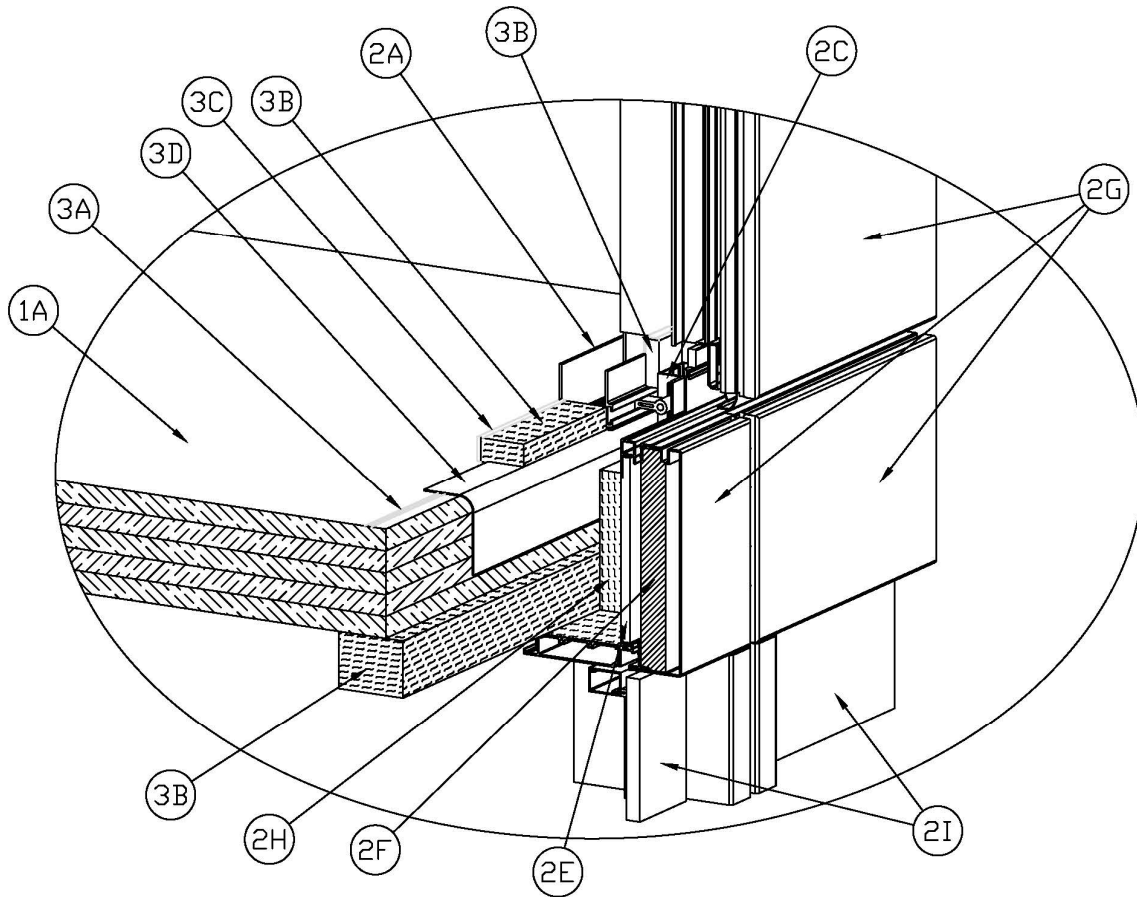

**Figure 1 - Isometric with Interior Vertical Mullion Detail**

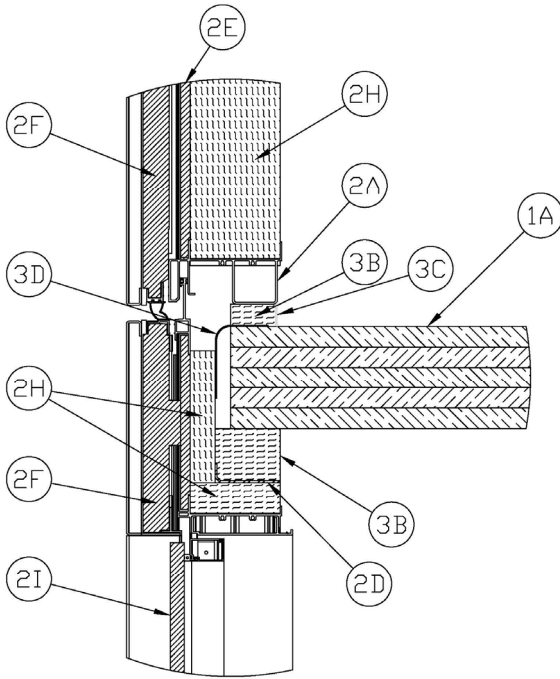

Figure 2 - Base Detail Between Anchors

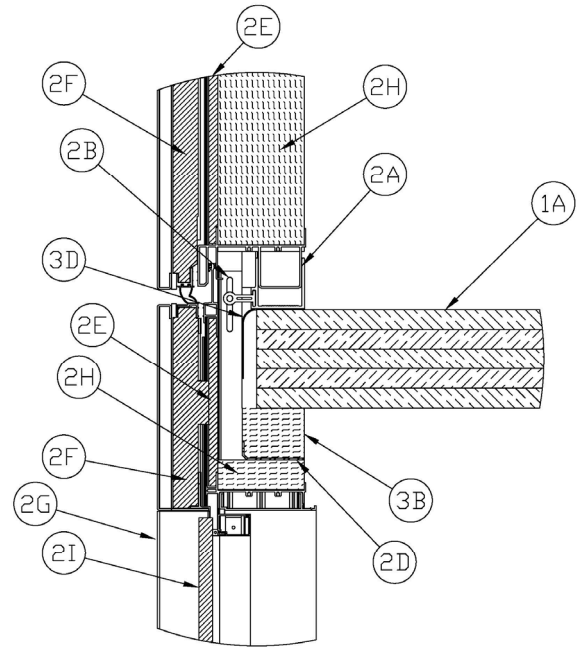

Figure 3 - Base Detail at Anchor (Jamb)

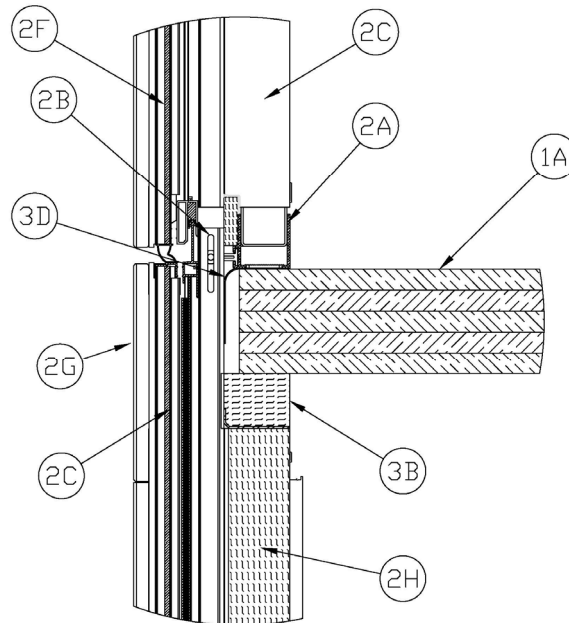

Figure 4 - Base Detail Between Wall Panels



**1. FLOOR ASSEMBLY:** Mass timber floor assembly shall have a min. 1 hr. fire resistance rating to ASTM E119, UL 263, and/or CAN/ULC S101 as applicable and the criteria described below in Item 1A. Fire resistance may also be calculated based on applicable building code provisions. F-rating will be determined by the rating of the floor system up to a max. 1-1/2 hr. F-rating. T-rating shall be a max. 1-1/4 hr., and for floor assemblies with a rating of less than 1-1/2 hr., T-rating shall be 1 hr.

A. **MASS TIMBER FLOOR ASSEMBLY** – Mass timber floor assembly to consist of min. 6-7/8 (175 mm) thick, min. 5-ply, cross-laminated timber (CLT). Mass timber floor shall be certified in accordance with ANSI/APA PRG-320 (2018 or later).

i. **GYPHUM BOARD:** (Optional, not shown) As an option, gypsum wallboard of any thickness, type, or layer quantity may be applied to the underside of the mass timber floor assembly. Install gypsum wallboard in accordance with wallboard manufacturer instructions and/or the local building code requirements.

ii. **FLOOR TOPPING:** (Optional, not shown) Use a code-compliant floor topping when acceptable for use in the listed or prescribed fire-rated floor/ceiling design.

iii. **ACOUSTICAL UNDERLAYMENT:** (Optional, not shown) When using a concrete floor topping (Item 1Aii), an acoustical underlayment may be installed between the mass timber floor assembly (Item 1A) and the concrete topping.

**2. WINDOW WALL ASSEMBLY:** Construct the exterior wall assembly in compliance with applicable building code and regulatory requirements. Spandrel panel shall extend a min. of 10-5/8 in. (270 mm) below the floor assembly (Item 1) and shall terminate into exterior cladding (Item 3F) or vision glass (Item

3H), a min. of 1/2 in. (13 mm) above the floor assembly, or into an exact duplicate of the spandrel panel profile with a max. 1 in. (25 mm) gap between the spandrel panel and the panel above at the stack joint. Duplicate panel profile may also terminate into exterior cladding (Item 3G) or vision glass (Item 3I). The wall is constructed such that the interior surface is slotted, nominally 4 in. (102 mm) deep at the floor line to accommodate the floor extending into the plane of the wall. The slot extends from the underside of the upper panel frame located nominally 2 in. (51 mm) above the top of the floor assembly to nominally 2-1/2 in. (64 mm) below the bottom of the floor assembly.

A. **MOUNTING ATTACHMENT** – The mounting attachments to the floor shall consist of 12 in. (305 mm) long × 3-1/4 in. (83 mm) wide × 3-1/4 in. (83 mm) tall, extruded aluminum U-Shaped anchor channels connecting to slots in the aluminum I-mullion structure via connecting hardware to control vertical position. The anchor channels are spaced 24 in. on center (oc) and the base is anchored to the top of the floor (Item 1) with min. 1/4 in. (6 mm) diameter lag screws extending a min. 2 in. (51 mm) into the floor.

B. **EXTERIOR ALUMINUM STUD FRAMING** – Wall panel structure is provided by min. 6 in. (152 mm) deep × 0.20 in. (5 mm) thick extruded I-shaped mullions spaced max. 24 in. oc.

C. **VERTICAL PANEL SEAM MULLION** – At vertical seams between panel sections, the panel structure is provided by a two-piece extruded aluminum mullion having a min 0.20 in. (5 mm) wall thickness. The mullion, when joined with the mating adjacent section, contains a wet chamber on the external side and dry chamber on the



internal side, and has a total depth of min. 6 in. (152 mm).

- D. UNIT TOP CHANNEL – At the top of the lower spandrel panel below the floor, install an extruded aluminum top channel to cap the mullion cavity. The space between the top channel and the underside of the floor is a max. distance of 3 in. (76 mm).
- E. EXTERIOR GRADE CORE BOARD – Use min. 5/8 in. (15.9 mm) exterior grade, glass-mat, gypsum wallboard or fiber-reinforced cement board mounted to the exterior side of the exterior aluminum stud framing (Item 3B). Secure with self-tapping drywall screws at max. 12 in. (305 mm) oc. If required, install on the exterior of the core board, an air/vapor barrier that complies with applicable building code and regulatory requirements.
- F. EXTERIOR INSULATION – Use min. 2 in. (51 mm) thick, nominal 8 pcf (128 kg/m<sup>3</sup>) density, exterior grade mineral wool or actual 6.2 pcf (100 kg/m<sup>3</sup>), Rockwool CavityRock mineral wool exterior continuous insulation, installed in accordance with the exterior curtain wall assembly (Item 2) design specifications.
- G. EXTERIOR CLADDING – Use an exterior cladding system that complies with applicable building code and regulatory requirements. Install in accordance with the exterior curtain wall assembly (Item 2) manufacturer's instructions and the design specifications. Ensure a max. 1 in. gap between the top of the spandrel panel and the exterior panel directly above, at the stack joint.

- H. **CERTIFIED PRODUCT:** Rockwool CurtainRock 80

INTERIOR INSULATION – Use min. 6 in. (152 mm) thick, faced or unfaced, min. 8 pcf (128 kg/m<sup>3</sup>) mineral wool curtain wall insulation placed in cavities between the exterior aluminum stud framing (Item 2B). Within the slotted section of the window wall assembly (Item 2), the interior insulation thickness is reduced to 2 in. (52 mm) in thickness and the top of the insulation in this space is recessed nominally up to 1 in. (25 mm) below the top of the floor assembly (Item 1).

- I. VISION PANELS – (Optional) Vision panels must comply with exterior curtain wall assembly (Item 2) design specifications. Glazing panels may be secured in position with aluminum pressure plates in conjunction with glazing gaskets and steel screws, or with structural silicone installed in accordance with the manufacturer's instructions.
  - J. EXTERIOR GRADE SEALANT – (Optional, not shown) At the seams between panels, exterior grade silicone sealant may be installed for weatherproofing as needed per the wall assembly design specifications.
3. **PERIMETER JOINT PROTECTION:** The perimeter joint (linear opening) is not to exceed 1 in. (25 mm) nominal joint width (joint width at installation) between the edge of slab and the interior surface of the wall.

The perimeter joint treatment shall incorporate the following construction features:



A. WEATHER SEAL – Install a nominal 3/8 in. bead of Specified Technologies, Inc. SpecSeal SIL300 on top of the floor assembly (Item 1) surface, 1 in. from the edge, before the Intumescent gasket (Item 3D) is placed on the floor and secured in place.

B. **CERTIFIED PRODUCT:** Rockwool Roxul Safe

PACKING MATERIAL – Install min. 4 in. thick (102 mm) 4 pcf (64 kg/m<sup>3</sup>) density mineral wool batt insulation, installed with the fibers running parallel to the bottom of the floor (Item 1). Measure the space between the Unit Top Channel (Item 2D) and the underside of the floor (Item 1). Divide that distance by 0.75 and cut that thickness of packing material to install with a 25% compression in the gap between the Unit Top Channel and underside of the floor. Install the batt insulation so that it is flush with the interior of the wall. Splices (butt joints) in the lengths of mineral wool batt insulation are to be tightly compressed together. In addition to the packing material between the underside of the floor and the Unit Top Channel, install mineral wool into the cavity space in the gaps between the U-Shaped anchor channels in the mounting attachment (Item 2A). Install mineral wool

compressed vertically 25% to fill that space to the interior vertical surface of the wall. Recess a min. 1/4 in. (6 mm) from the interior surface of the mounting attachment.

C. FILL, VOID, OR CAVITY MATERIAL – Apply Specified Technologies, Inc. SpecSeal® SIL300 Silicone Sealant at a min. wet film thickness of 1/4 in. (6 mm) over the packing material (Item 3A) that is installed between the anchor channels of the mounting attachment (Item 2A) on the top side of the floor. Also install a 1/4 in. depth over the packing material that is visible at the top of the vertical panel seam mullion (Item 2C).

D. **CERTIFIED PRODUCT:** Specified Technologies, Inc. SpecSeal® WWG Window Wall Gasket

FILL, VOID, OR CAVITY MATERIAL – Nominal 1/8 in. (3 mm) thick and 8 in. (203 mm) wide intumescent gasket is positioned so that a nominal 2 in. portion of the width overlaps the top of the floor along the floor edge. The intumescent gasket is secured to top of the floor assembly (Item 1) with nominal 1-1/4 in. (32 mm), 1/4 in. (6 mm) diameter wood screws and fender washers spaced 12 in. (305 mm) oc.

*Consult the listing report on the Directory of Building Products (<https://bpdirectory.intertek.com>) for the edition of the standard(s) evaluated.*

*Compliance of the assembly described in this Design Listing with the referenced standard relies on verification that the assembly constructed in the field is consistent with that described herein. Intertek certified products may be verified by the approved Intertek label; other products must be verified by the Authority Having Jurisdiction as meeting the specifications stated herein.*