Specified Technologies, Inc.
Design No. STI/BPF 120-43
Perimeter Fire Barrier System – Curtain Wall Assembly
SpecSeal® AS200 Series Elastomeric Spray
SpecSeal® Fast Tack® Firestop Spray
ASTM E2307, CAN/ULC-S115
Rating: F-Rating – 2 hr.
UL 2079 L-Rating < 2 SCFM/LF
Movement Type = Class IV
Rated for ± 5% Vertical Movement at 25% Compression (Item 3A)

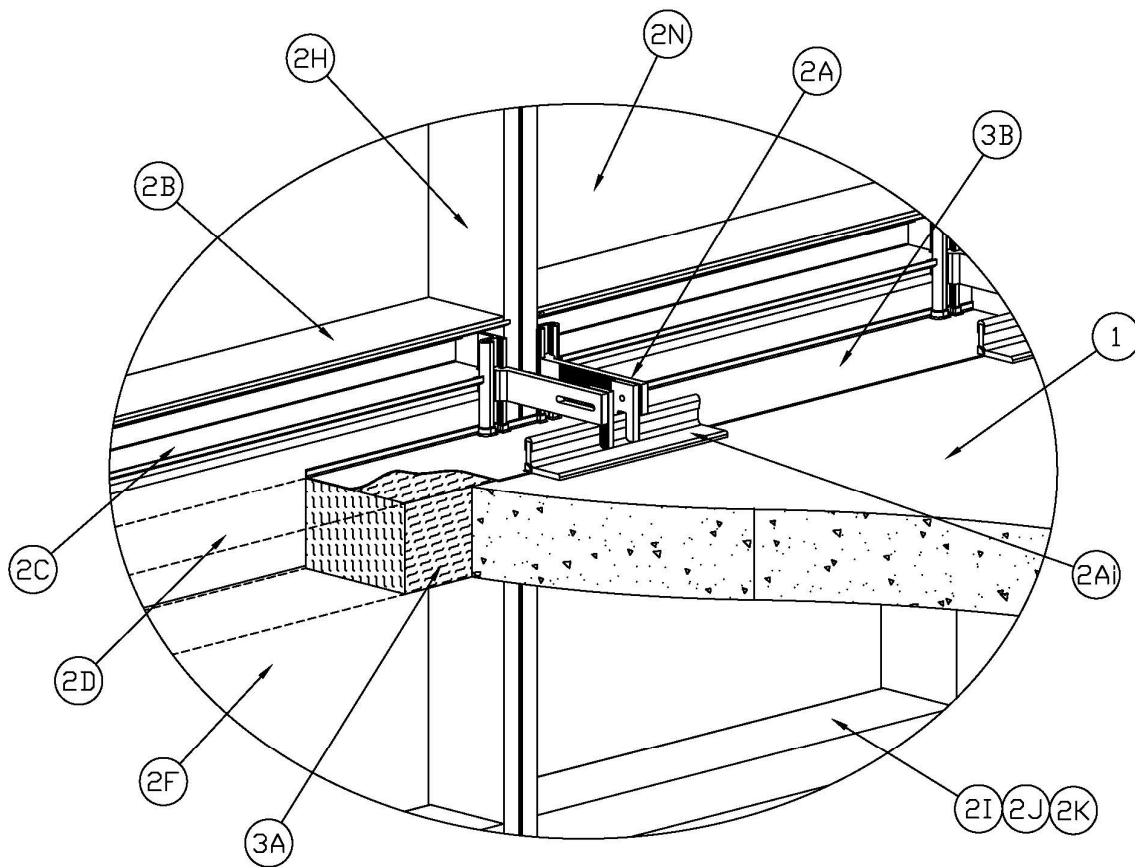

Figure 1 - Isometric with Interior Vertical Mullion Detail

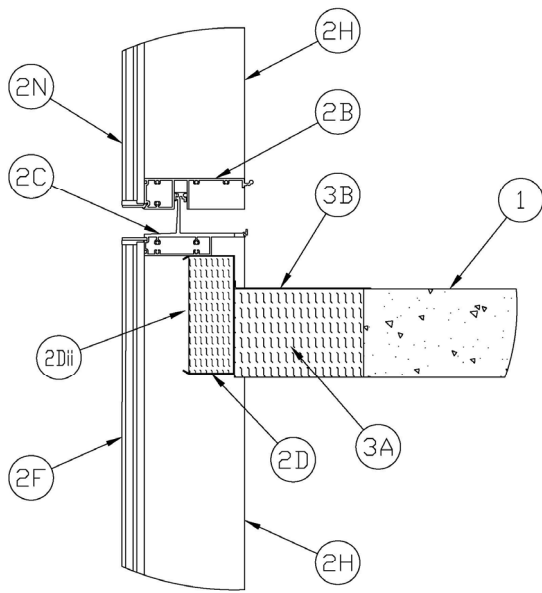

Figure 2 - Base Detail Between Anchors

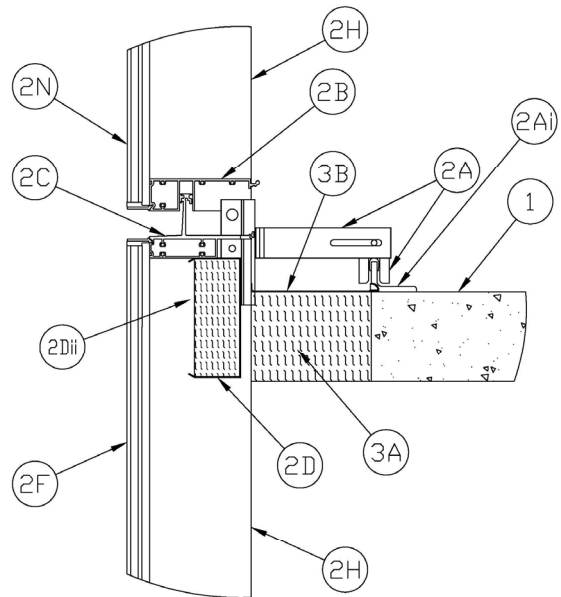

Figure 3 - Base Detail at Anchor

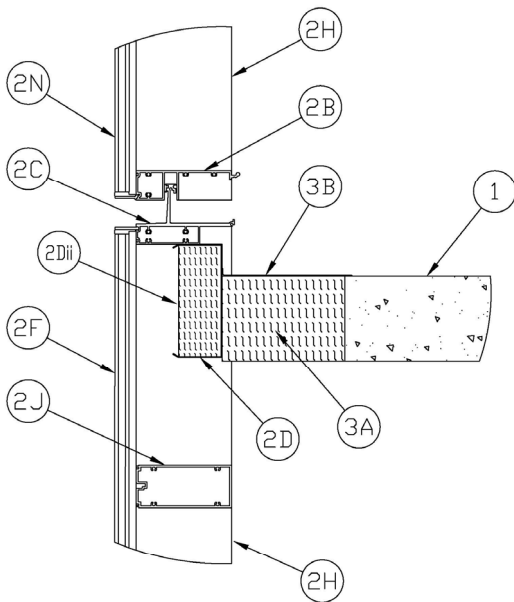

Figure 4 - Kiss Transom Configuration

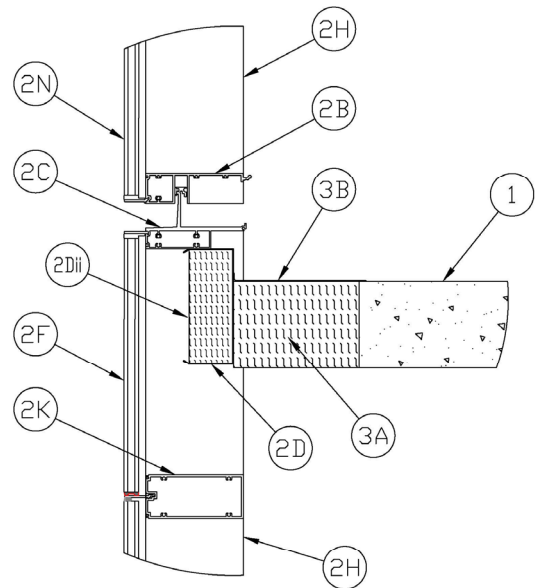

Figure 5 - Captured Transom Configuration

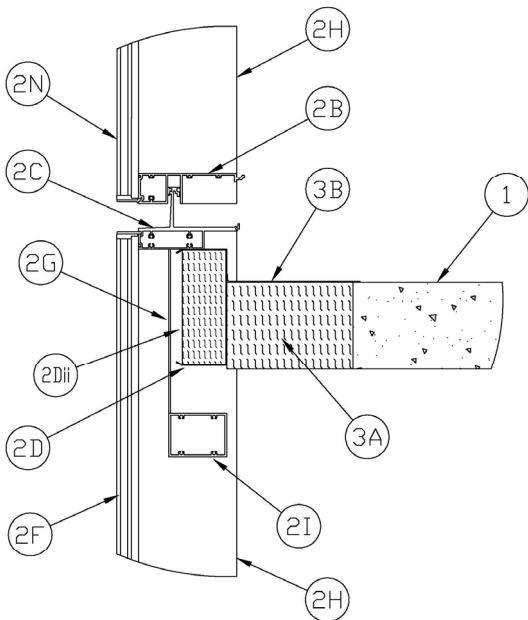

Figure 6 - Intermediate Transom with Shadow Box

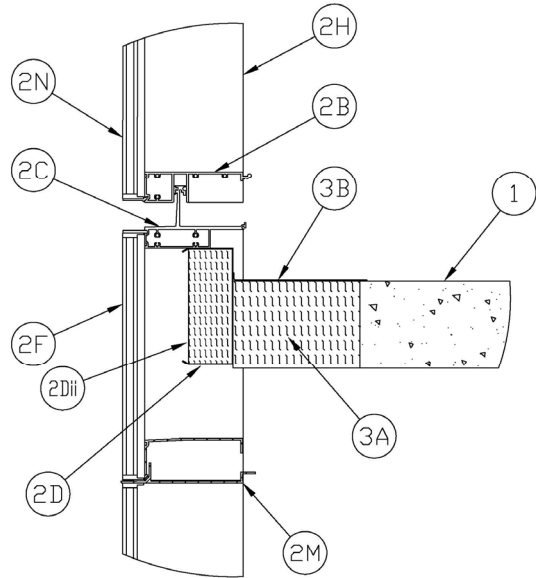

Figure 7 - Windload Anchor Configuration

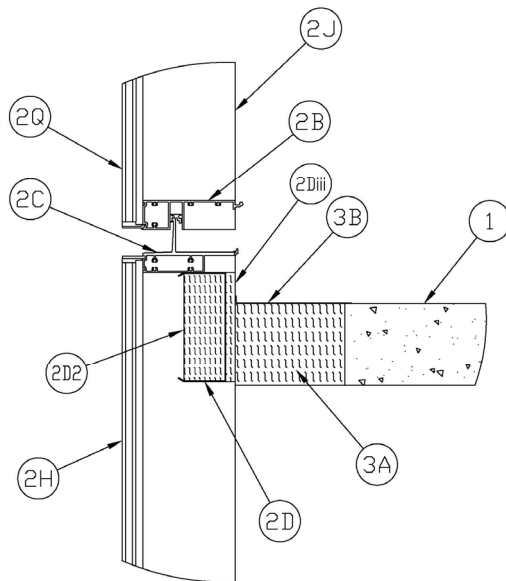

Figure 8 - Base Detail Interior Backpan Insulation



1. **FLOOR ASSEMBLY:** Concrete floor assembly shall have a minimum fire resistance rating of 2 hr. to ASTM E119, UL 263, or CAN/ULC S101 as applicable.

A. **CONCRETE FLOOR ASSEMBLY:** Concrete floor may be comprised of min. 2-hr rated concrete made from either lightweight or normal weight concrete with a density of 100-150 pcf, with a min. thickness of 6 in. (152 mm) at the joint face. F-rating will be determined by the rating of the floor system up to a max 2-hr F-rating.

2. **CURTAIN WALL ASSEMBLY:** Construct the exterior wall assembly in compliance with applicable building codes and regulatory requirements. The core of the spandrel, comprised of all components noted in Items 2B through 2D below, spans from a min. 7-1/8 in. (181 mm) above the concrete floor assembly (Item 1A) to flush with the bottom of the concrete floor or lower. Other elements that exist within the spandrel and are marked optional are complimentary to the design and shall be installed per the curtain wall manufacturer's design specifications.

A. **MOUNTING ATTACHMENT:** Each anchor is formed of extruded aluminum with a serrated surface that is mated to a serrated surface of an 11/16 in. (17.5 mm) extruded aluminum slotted bar having a min. length of 2 in. (51 mm) and a max. length of 9-9/16 in. (243 mm). The "tomahawk" components described above are secured together using a nominal 3/8 in. (10 mm) steel bolt and two

jackscrews. The vertical leg of the 11/16 in. (17.5 mm) serrated bar is inserted into the channel slot of the mullion receiver bolted to the side of each mullion. Anchors have one slotted end resting atop the vertical leg of the steel angle anchor support (Item 2Ai) on both sides of each mullion. The anchor is attached to the mullion with steel bolts per the manufacturer's design.

i. **ANCHOR SUPPORT:** Install min. 2 in. × 3 in. × 3/8 in. (50 mm × 76 mm × 9.5 mm) steel angle, as shown in Figure 1, set above the concrete floor assembly (Item 1A), with the vertical leg of the angle flush with the edge of the floor. Secure the angle to the top-side of the concrete floor with embedded concrete anchors in accordance with the wall manufacturer's installation instructions.

B. **UPPER TRANSOM:** The sill of the upper transom is positioned nominally 7-1/8 in. (181 mm) above the top of the concrete floor assembly (Item 1A) and the underside of the transom is positioned a min. 1-7/8 in. (48 mm) above the floor. The upper transom consists of nominal 1/8 in. (3 mm) extruded aluminum with an exterior wet chamber and interior geometry that receives the "chicken head" from the anchor head extrusion (Item 2C), forming the stack joint. The front-to-back width of the upper transom is min. 6-3/4 in. (171 mm).



C. **ANCHOR HEAD:** The anchor head consists of nominal 1/8 in. (3 mm) thick extruded aluminum having a complex shape and a nominal 3 in. (76 mm) slot on the interior side of the transom. The height of the anchor head extrusion, from the bottom to the top of the “chicken head”, is nominally 4-1/4 in. (108 mm) and the width from front to back is 6-3/4 in. (171 mm). The anchor head contains a wet chamber on the exterior side and on the interior may be constructed with a single or double “chicken head” per the design of the manufacturer. The upper transom (Item 2B) and the anchor head engage at the stack joint and the bottom of the anchor head extrusion is positioned a min. 1-7/8 in. (48 mm) above the top of the concrete floor assembly (Item 1A) surface.

D. **STEEL VALANCE BACKPAN:** The valance backpan is constructed with 22 GA galvanized sheet steel. The backpan extends horizontally from vertical mullion to vertical mullion (Item 2H) and is secured to the mullions and the anchor head with No. 10 steel sheet metal screws spaced 12 in. (305 mm) on center (oc). Each screw head may be covered with silicone sealant. The pan shall measure a min. 8 in. (152 mm) vertical height and a min. 3 in. (76 mm) depth. Silicone sealant may be installed around the perimeter of backpan. The back, or interior side of the backpan may be mounted flush with the interior of the anchor head or recessed up to 15/16 in. (24 mm) from the interior edge of the mullions. The valance backpan shall incorporate the following

construction features, unless stated as optional:

- i. **INSULATION PINS:** weld min. 12 GA, steel impaling pins or steel cup-head pins to the vertical centerline of the pan. Ensure the length of the pin is sufficient to hold the insulation snugly to the pan without compression. When impaling pins are used, secure insulation with speed washers. Pins are to be spaced a max. 12 in. (305 mm) from the perimeter of the backpan and max. 13-1/2 in. (343 mm) spacing oc. When vertical splices are incorporated, pins are to be placed at a max. 6 in. (152 mm) spacing from the splice on both sides. A min. of 2 pins is required for each individual section of backpan insulation (Item 2Dii).
- ii. **CERTIFIED PRODUCT:** Thermafiber Firespan 90

BACKPAN INSULATION: Install min. 3 in. (76 mm) thick, 8 pcf (128 kg/m³) density mineral wool into the backpan. The insulation is to be fitted tightly to the perimeter of the pan and secured with steel impaling pins or steel cuphead pins (Item 2Di). Insulation may be installed with vertical splices as required. When vertical splices are present, install insulation with a 1/4 in. (1/8 in. from each side) compression. Use no less than 2 pins for each uninterrupted section of mineral wool, and follow the pin spacing guidelines in



Item 2Di. If the backpan extends above the concrete floor assembly (Item 1A), min. 22 GA, 1-1/2 in. × 1-1/2 in. (38 mm × 38 mm) steel angle is to be stitch welded to the backpan, inside the pan, so that the horizontal stiffening leg is level with the top of the floor within +/- 1/2 in. (13 mm).

- iii. **CERTIFIED PRODUCT:** Thermafiber Firespan 90

INTERIOR BACKPAN INSULATION (Optional): Intertek certified, noncombustible, foil-faced, max. 1 in., 8 pcf (128 kg/m³) density mineral wool may be installed over the interior of the backpan so it is flush with the interior edge of the vertical mullions. Insulation may be secured with welded or adhesive backed impaling pins or may be friction fitted into place and held in position by the compression of the packing material (Item 3A).

- E. **ADDITIONAL INSULATIVE MATERIALS:** (Optional, not shown) In any space that exists below the valance backpan (Item 2D), where insulation is required for energy conservation requirements or other purposes, the space may be filled with any material that complies with applicable building code and regulatory requirement.
- F. **EXTERIOR SPANDREL CLADDING:** (Optional) Install glazing or an exterior cladding system that complies with applicable building code and regulatory

requirements. Install in accordance with the exterior curtain wall assembly manufacturer's instructions and the design specifications. Glazing panels or other specified cladding may be secured in position with aluminum pressure plates in conjunction with glazing gaskets and steel screws or with structural silicone installed in accordance with the manufacturer's instructions.

- G. **SHADOW BOX:** (Optional, not shown) A shadow box installed on the exterior side of the valance backpan (Item 2D) may be formed of any material that complies with applicable building code and regulatory requirements. Install in accordance with the exterior curtain wall assembly manufacturer's instructions and the design specifications.
- H. **VERTICAL MULLIONS:** Vertical mullions are constructed of nominal 1/8 in. (3 mm) thick extruded aluminum. Mullions can be constructed as solid members, or as joining members that are split vertically. Mullions are designed with a wet chamber on the exterior side and a dry chamber on the interior side. Mullions have a min. depth of 6-3/4 in. (171 mm) and a min. width of 3 in. (76 mm). Spacing of the mullions is min. 40-1/2 in. (1.02 m) oc.
- I. **INTERMEDIATE TRANSOM:** (Optional, not shown) An intermediate transom may be installed on the underside of the valance backpan (Item 2D) and may be formed of any material that complies with applicable



building code and regulatory requirements. Install in accordance with the exterior curtain wall assembly manufacturer's instructions and the design specifications.

- J. **CONTINUOUS GLAZING FRAME (KISS TRANSOM):** (Optional, not shown) A continuous glazing frame (Kiss Transom) may be installed below the valance backpan (Item 2D) and may be formed of any material that complies with applicable building code and regulatory requirements. Install in accordance with the exterior curtain wall assembly manufacturer's instructions and the design specifications.
- K. **CAPTURED TRANSOM:** (Optional, not shown) A captured transom that utilizes either aluminum pressure plates in conjunction with glazing gaskets and steel screws or with structural silicone installed in accordance with the manufacturer's instructions may be installed below the valance backpan (Item 2D) and may be formed of any material that complies with applicable building code and regulatory requirements. Install in accordance with the exterior curtain wall assembly manufacturer's instructions and the design specifications.
- L. **ARCHITECTURAL COVER:** (Optional, not shown) An architectural cover that hides the perimeter joint protection (Item 3) may be installed in accordance with the exterior curtain wall assembly manufacturer's instructions and the design specifications.

- M. **WINDLOAD ANCHOR:** (Optional, not shown) A windload anchor may be installed on the wall, below the valance backpan (Item 2D) and may be formed of any material that complies with applicable building code and regulatory requirements. Install in accordance with the exterior curtain wall assembly manufacturer's instructions and the design specifications.
- N. **VISION PANELS:** Vision panels are to be in compliance with exterior curtain wall assembly (Item 2) design specifications. Glazing panels may be secured in position with aluminum pressure plates in conjunction with glazing gaskets and steel screws or with structural silicone installed in accordance with the manufacturer's instructions.

- 3. **PERIMETER JOINT PROTECTION:** The perimeter joint (linear opening) is not to exceed 8 in. (203 mm) nominal joint width (joint width at installation). The perimeter joint treatment shall incorporate the following construction features:

- A. **CERTIFIED PRODUCT:** Thermafiber Safing

PACKING MATERIAL: Install a min. 6 in. (152 mm) depth, as measured vertically from the top of the concrete floor assembly (Item 1A), of 4 pcf (64 kg/m³) density mineral wool batt insulation installed with the fibers running parallel to the floor edge and curtainwall. Divide the nominal joint width, as measured by the distance from the edge of the floor to the interior edge of the mullion face, by 0.75 to provide the



width of mineral wool to be cut and installed to produce the required min. 25% compression in the nominal joint width. Where the backpan (Item 2D) is recessed, and interior backpan insulation (Item 2Diii) is not used, compression between the floor edge and the backpan must maintain a min. 16% compression. Install the batt insulation into the perimeter joint flush with the top surface of the concrete floor assembly (Item 1A). Max. of 2 splices (butt joints) in the lengths of mineral wool batt insulation are to be tightly compressed together.

- B. **CERTIFIED PRODUCT:** Specified Technologies, Inc. SpecSeal® AS200 Series Elastomeric Firestop Spray, or SpecSeal® Fast Tack® Firestop Spray

FILL VOID OR CAVITY MATERIAL: Apply a min. wet film thickness of 1/8 in. (3 mm) over the packing material (Item 3A) and overlap the liquid spray material a min. 1/2 in. (12.7 mm) onto the interior surface of the adjacent curtain wall assembly (Item 2) and the concrete floor assembly (Item 1A). If the spraying process is stopped and the applied liquid spray material cures to an elastomeric film before the process is restarted, then overlap the edge of the cured spray material at least 1/8 in. (3 mm) with the liquid spray material.

Consult the listing report on the Directory of Building Products (<https://bpdirectory.intertek.com>) for the edition of the standard(s) evaluated.

Compliance of the assembly described in this Design Listing with the referenced standard relies on verification that the assembly constructed in the field is consistent with that described herein. Intertek certified products may be verified by the approved Intertek label; other products must be verified by the Authority Having Jurisdiction as meeting the specifications stated herein.



Division 07 – Thermal and Moisture Protection
07 84 00 Firestopping
07 84 53 Building Perimeter Firestopping