

---

**Specified Technologies, Inc.**  
**Design No. STI/BPF 120-45**  
**Perimeter Fire Barrier System – Curtain Wall Assembly**  
**SpecSeal® AS200 Series Elastomeric Spray**  
**SpecSeal® Fast Tack® Firestop Spray**  
**ASTM E2307, CAN/ULC-S115**  
**Rating: F-Rating – 2 hr.**  
**UL 2079 L-Rating < 2 SCFM/LF**  
**Movement Type = Class IV**  
**Rated for ± 5% Vertical Movement at 25% Compression (Item 3A)**

---

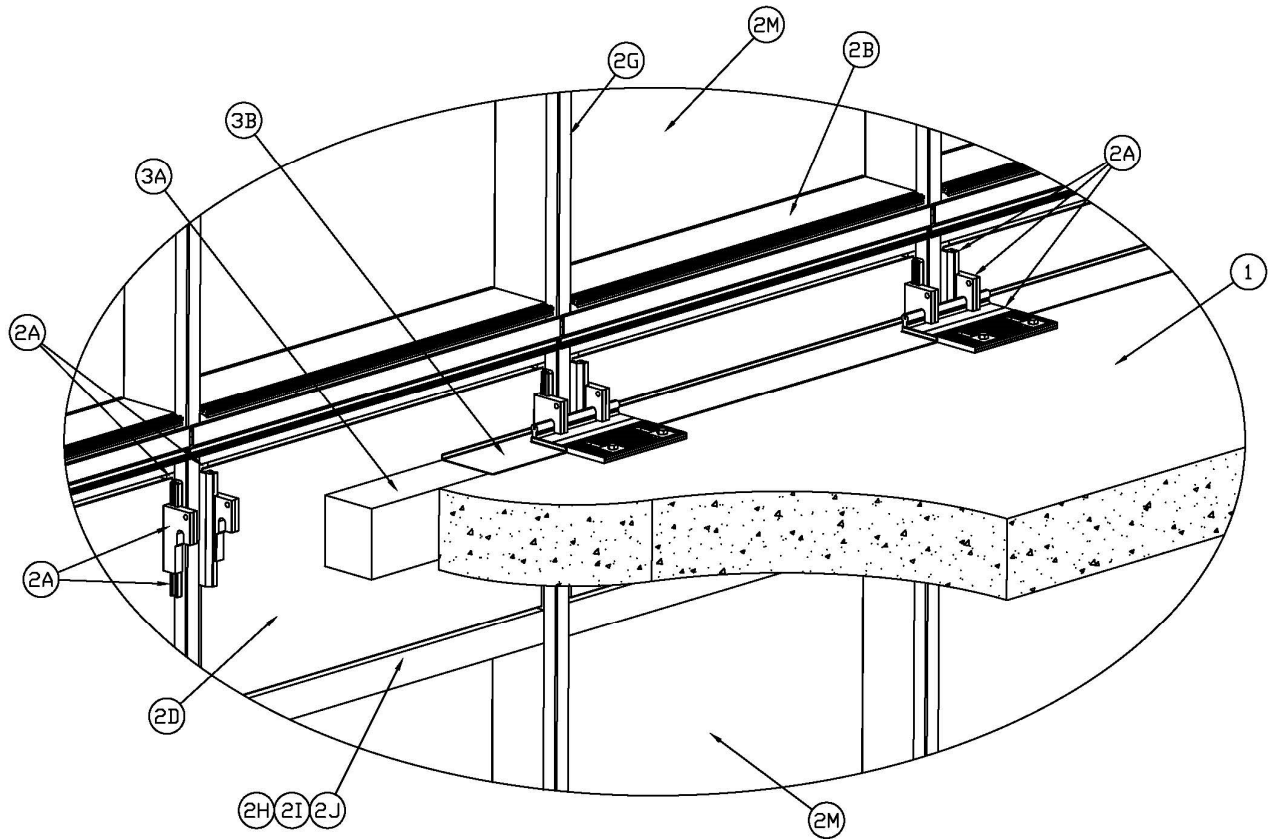

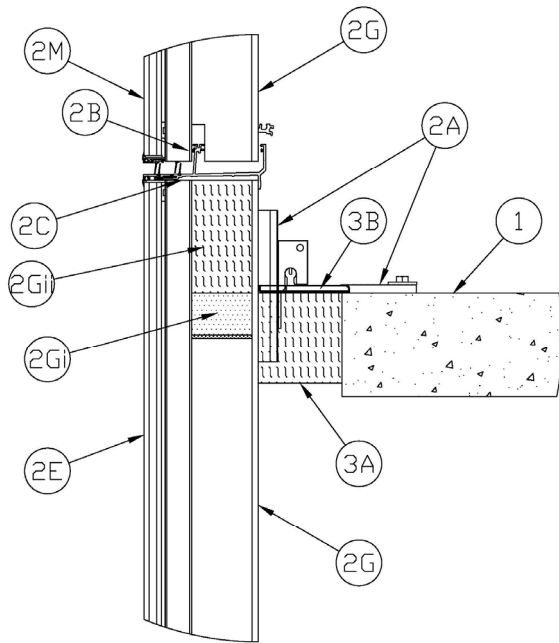

Figure 2 - Base Detail at Anchors (Top of Slab)

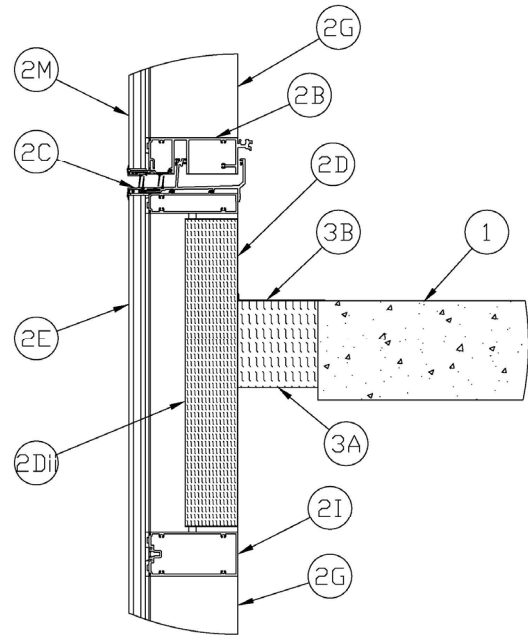

Figure 3 - Base Detail Between Anchors (Kiss Transom)

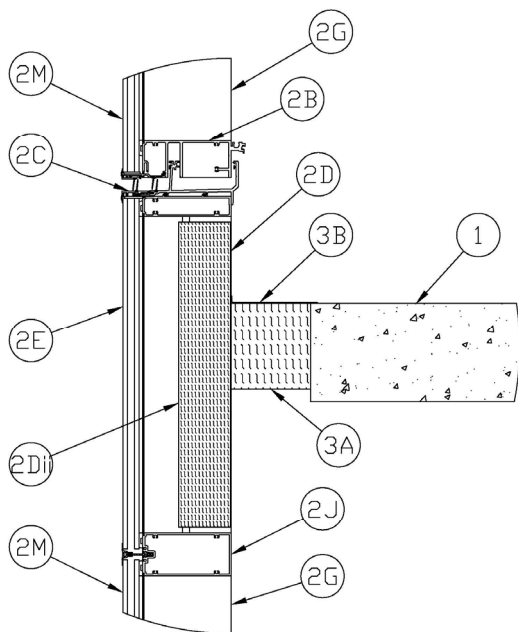

Figure 4 - Base Detail Between Anchors (Captured Transom)

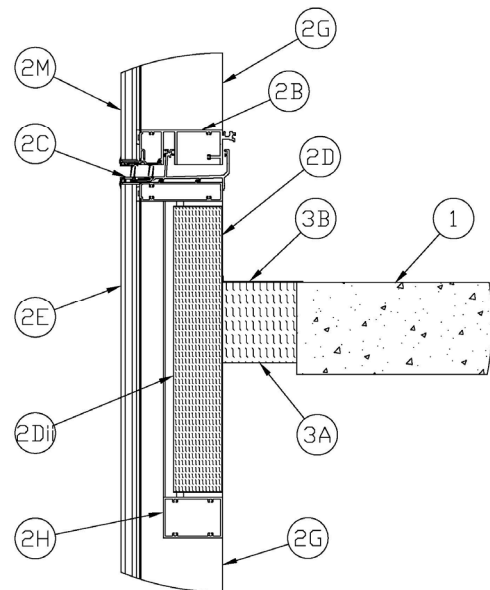

Figure 5 - Base Detail Between Anchors (Intermediate Transom)

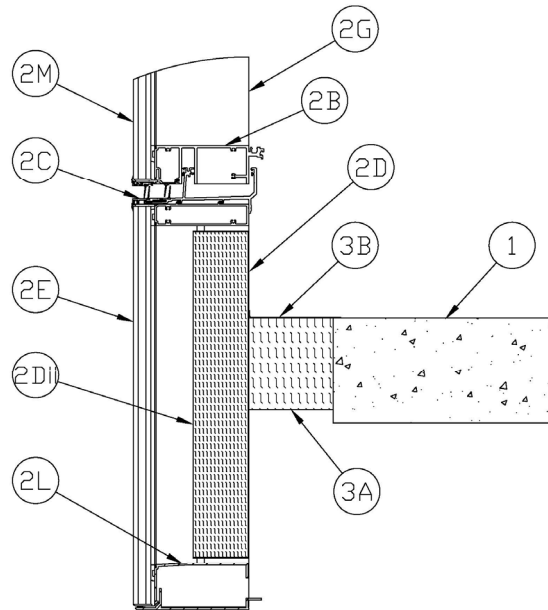

Figure 6 - Windload Anchor Configuration

**1. FLOOR ASSEMBLY:** Concrete floor assembly shall have a minimum fire resistance rating of 1 hr. to ASTM E119, UL 263, or CAN/ULC S101 as applicable.

**A. CONCRETE FLOOR ASSEMBLY:** Concrete floor may be comprised of min. 1-hr rated concrete made from either lightweight or normal weight concrete with a density of 100-150 pcf, with a min. thickness of 6 in. (152 mm) at the joint face. F-rating will be determined by the rating of the floor system up to a max. 2-hr F-rating.

**2. CURTAIN WALL ASSEMBLY:** Construct the exterior wall assembly in compliance with applicable building codes and regulatory

requirements. The core of the spandrel, comprised of all components noted in Items 2B through 2D below, spans from a min. 6 in. (152 mm) above the concrete floor assembly (Item 1A) to a min. 8-1/8 in. (206 mm) below the bottom of the concrete floor assembly. Other elements that exist within the spandrel and are marked optional are complimentary to the design and shall be installed per the curtain wall manufacturer's design specifications.

**A. MOUNTING ATTACHMENT:** Secure the wall system to the concrete floor by means of a top-mounted extruded aluminum anchor plate measuring min 1/2 in. (13 mm) in thickness. Secure to the top of the concrete floor assembly (Item 1) in accordance with



the curtain wall manufacturer's instructions with two 1/2 in. (13 mm) × 4 in. (102 mm) steel masonry anchors with serrated washer plates as supplied by the anchor manufacturer. Top-mounted plate connects with mullion anchor plates measuring min 3/8 in. (10 mm) having a vertical height of min. 10 in. (254 mm) and a width of 3 in. (76 mm) positioned so that 2 in. (51 mm) are inserted between the backpan flange and the mullion on both sides of the mullion. The top-mounted anchor plate engages with fist sliders on the side mullion anchor plates. The fist sliders may extend from above the floor to a min. 1 in. (25 mm) above the bottom of the packing material (Item 3A).

- B. **UPPER TRANSOM:** The sill of the upper transom is positioned nominally 11-1/4 in. (286 mm) above the top of the concrete floor assembly (Item 1A) and the underside of the transom is positioned a min. 6 in. (152 mm) above the floor. The upper transom consists of nominal 0.10 in. (2.5 mm) extruded aluminum with an exterior wet chamber and interior geometry that receives the double “chicken head” from the anchor head extrusion (Item 2C), forming the stack joint. The front-to-back width of the upper transom is min. 6-1/8 in. (156 mm).
- C. **ANCHOR HEAD:** The anchor head consists of nominal 0.10-in. (2.5 mm) thick extruded aluminum having a complex shape. The height of the anchor head extrusion, from the bottom to the top of the “chicken

head,” is nominally 3-3/4 in. (95 mm) and the width from front to back is 6-1/8 in. (156 mm). The anchor head contains a wet chamber on the exterior side and on the interior is constructed with a double “chicken head” per the design of the manufacturer. The upper transom (Item 2B) and the anchor head engage at the stack joint and the bottom of the anchor head extrusion is positioned a min. 6 in. (152 mm) above the top of the concrete floor assembly (Item 1A) surface.

- D. **STEEL BACKPAN:** The backpan is constructed with 22 GA galvanized sheet steel. The backpan extends horizontally from vertical mullion to vertical mullion (Item 2G) and is secured to the mullions and the anchor head with No. 10 steel sheet metal screws spaced 12 in. (305 mm) on center (oc). Each screw head may be covered with silicone sealant. The pan shall measure a min. 21 in. (533 mm) vertical height and a min. 4 in. (76 mm) depth. The backpan shall incorporate a min. of one horizontal T-shaped stiffener angle, spot welded to the interior side of the backpan. The stiffener angle shall be constructed of min 22 ga. Steel, with min. 1.5 in. legs, and located in the plane of the floor, no lower than 6 in. (152 mm) below the top of the floor. Silicone sealant may be installed around the perimeter of backpan. The back, or interior side of the backpan is mounted flush with the interior of the anchor head and interior face of the mullions. As an option, the backpan flanges may be positioned with up to a 3/8 in. (10 mm) gap



between the pan and the aluminum framing. When the backpan is installed with such a gap around the perimeter, nominal 1/2 in. (8 mm) wide by 5/16 in. (8 mm) thick adhesive backed polyurethane foam glazing tape may be installed between the pan and the framing. Tape is recessed nominal 1/4 in. (6 mm) to accommodate one-part silicone sealant to be applied at nominal 1/4 in. (6 mm) depth over the recessed tape, around the perimeter of the pan. Any gap that exists between the backpan and the aluminum framing of the spandrel above the fist slider of the mounting attachment (Item 2A) shall be filled with nominal 4 pcf (64 kg/m<sup>3</sup>) density mineral wool batt insulation (Item 3A) to a min. depth of 2 in. (51 mm) at the upper corner of the backpan. The backpan shall incorporate the following construction features, unless stated as optional:

- i. **INSULATION PINS:** Weld min. 12 GA, steel impaling pins or steel cup-head pins to the interior side of the backpan. Ensure the length of the pin is sufficient to hold the insulation snugly to the pan without compression. When impaling pins are used, secure insulation with speed washers. Pins are to be spaced a max. 4 in. (102 mm) from the perimeter of the backpan and max. 24 in. (609 mm) spacing oc horizontally and max 12 in. (305 mm) spacing vertically. When vertical splices are incorporated, pins are to be placed at a max. 6 in. (152 mm) spacing from the splice on both sides. A min. of 2 pins are required for each

individual section of backpan insulation (Item 2Dii).

- ii. **CERTIFIED PRODUCT:** Thermafiber Firespan 90

**BACKPAN INSULATION:** Install min. 3 in. (76 mm) thick, 8 pcf (128 kg/m<sup>3</sup>) density mineral wool into the backpan. The insulation is to be fitted tightly to the perimeter of the pan and secured with steel impaling pins or steel cuphead pins (Item 2Di). Insulation may be installed with vertical splices as required. When vertical splices are present, install insulation with a 1/4 in. (1/8 in. from each side) compression. Use no less than 2 pins for each uninterrupted section of mineral wool, and follow the pin spacing guidelines in (Item 2Di).

- iii. **CERTIFIED PRODUCT:** Thermafiber Firespan 90

**ALTERNATIVE INSULATIVE MATERIALS:** (Optional, not shown) In any space that exists below the backpan (Item 2D), where insulation is required for energy conservation requirements or other purposes, the space may be filled with any material that complies with applicable building code and regulatory requirement.

- E. **EXTERIOR SPANDREL CLADDING:** (Optional) Install glazing or an exterior cladding system that complies with



applicable building code and regulatory requirements. Install in accordance with the exterior curtain wall assembly manufacturer's instructions and the design specifications. Glazing panels or other specified cladding may be secured in position with aluminum pressure plates in conjunction with glazing gaskets and steel screws or with structural silicone installed in accordance with the manufacturer's instructions.

F. **SHADOW BOX:** (Optional, not shown) A shadow box installed on the exterior side of the backpan (Item 2D) may be formed of any material that complies with applicable building code and regulatory requirements. Install in accordance with the exterior curtain wall assembly manufacturer's instructions and the design specifications.

G. **VERTICAL MULLIONS:** Vertical mullions are constructed of nominal 0.10 in. (2.5 mm) extruded aluminum. Mullions can be constructed as solid members, or as joining members that are split vertically. Mullions are designed with a wet chamber on the exterior side and a dry chamber on the interior side. Mullions have a min. depth of 6-1/8 in. (156 mm) and a min. width of 3 in. (76 mm). Spacing of the mullions is min. 40-1/2 in. (1.02 m) oc.

i. **MULLION PLUG:** When a true stack joint is present, a specified Technologies, Inc. SpecSeal® Mullion Plug must be applied within the dry cavity of the mullion, with the top edge of the mullion foam

flush with the top of the floor and with the intumescent side of the plug facing downward. Plug shall be cut to match the profile of the mullion cavity it is placed in and sized slightly larger than the cavity as to fully fill the space form a friction fit.

ii. **CERTIFIED PRODUCT:** Thermafiber Safing

**MULLION FILLER:** Any dry cavity space that exists above the mullion plug (Item 2Gi), up to the bottom of the true stack joint, must be filled with 4 pcf (64 kg/m<sup>3</sup>) density mineral wool, loosely packed into the cavity space.

H. **INTERMEDIATE TRANSOM:** (Optional, not shown) An intermediate transom may be installed on the underside of the backpan (Item 2D) and may be formed of any material that complies with applicable building code and regulatory requirements. Install in accordance with the exterior curtain wall assembly manufacturer's instructions and the design specifications.

I. **CONTINUOUS GLAZING FRAME (KISS TRANSOM):** (Optional, not shown) A continuous glazing frame (Kiss Transom) may be installed below the backpan (Item 2D) and may be formed of any material that complies with applicable building code and regulatory requirements. Install in accordance with the exterior curtain wall assembly manufacturer's instructions and the design specifications.



- J. **CAPTURED TRANSOM:** (Optional, not shown) A captured transom that utilizes either aluminum pressure plates in conjunction with glazing gaskets and steel screws or with structural silicone installed in accordance with the manufacturer's instructions may be installed below the backpan (Item 2D) and may be formed of any material that complies with applicable building code and regulatory requirements. Install in accordance with the exterior curtain wall assembly manufacturer's instructions and the design specifications.
- K. **ARCHITECTURAL COVER:** (Optional, not shown) An architectural cover that hides the perimeter joint protection (Item 3) may be installed in accordance with the exterior curtain wall assembly manufacturer's instructions and the design specifications.
- L. **WINDLOAD ANCHOR:** (Optional, not shown) A windload anchor may be installed on the wall, below the backpan (Item 2D) and may be formed of any material that complies with applicable building code and regulatory requirements. Install in accordance with the exterior curtain wall assembly manufacturer's instructions and the design specifications.
- M. **VISION PANELS:** Vision panels are to be in compliance with exterior curtain wall assembly (Item 2) design specifications. Glazing panels may be secured in position with aluminum pressure plates in conjunction with glazing gaskets and steel

screws or with structural silicone installed in accordance with the manufacturer's instructions.

- 3. **PERIMETER JOINT PROTECTION:** The perimeter joint (linear opening) is not to exceed 5-1/2 in. (203 mm) nominal joint width (joint width at installation). The perimeter joint treatment shall incorporate the following construction features:

- A. **CERTIFIED PRODUCT:** Thermafiber Safing

**PACKING MATERIAL:** Install a min. 6 in. (152 mm) depth, as measured vertically from the top of the concrete floor assembly (Item 1A), of 4 pcf (64 kg/m<sup>3</sup>) density mineral wool batt insulation installed with the fibers running parallel to the floor edge and curtainwall. Divide the nominal joint width, as measured by the distance from the edge of the floor to the interior edge of the mullion face, by 0.75 to provide the width of mineral wool to be cut and installed to produce the required min. 25% compression in the nominal joint width. Install the batt insulation into the perimeter joint flush with the top surface of the concrete floor assembly (Item 1A). Max. of 2 splices (butt joints) in the lengths of mineral wool batt insulation between anchors are to be tightly compressed together.

- B. **CERTIFIED PRODUCT:** Specified Technologies, Inc. SpecSeal® AS200 Series Elastomeric Firestop Spray, or SpecSeal® Fast Tack® Firestop Spray



**FILL VOID OR CAVITY MATERIAL:** Apply a min. wet film thickness of 1/8 in. (3 mm) over the packing material (Item 3A) and overlap the liquid spray material a min. 1/2 in. (12.7 mm) onto the interior surface of the adjacent curtain wall assembly (Item 2) and the concrete floor assembly (Item 1A). If the spraying process is stopped and the applied liquid spray material cures to an elastomeric film before the process is restarted, then overlap the edge of the

cured spray material at least 1/8 in. (3 mm) with the liquid spray material. In addition to the concrete floor assembly (Item 1A), the overlapping edge of the sealant, on the floor edge side, may only be applied to noncombustible concrete or metallic surfaces/floor toppings.

*Consult the listing report on the Directory of Building Products (<https://bpdirectory.intertek.com>) for the edition of the standard(s) evaluated.*

*Compliance of the assembly described in this Design Listing with the referenced standard relies on verification that the assembly constructed in the field is consistent with that described herein. Intertek certified products may be verified by the approved Intertek label; other products must be verified by the Authority Having Jurisdiction as meeting the specifications stated herein.*