

Figure 2 - Base Detail Between Anchors

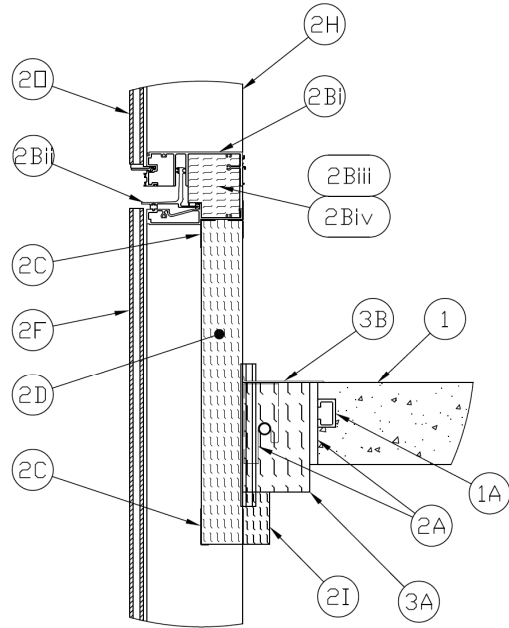

Figure 3 - Base Detail at Anchor (Face Mounted)

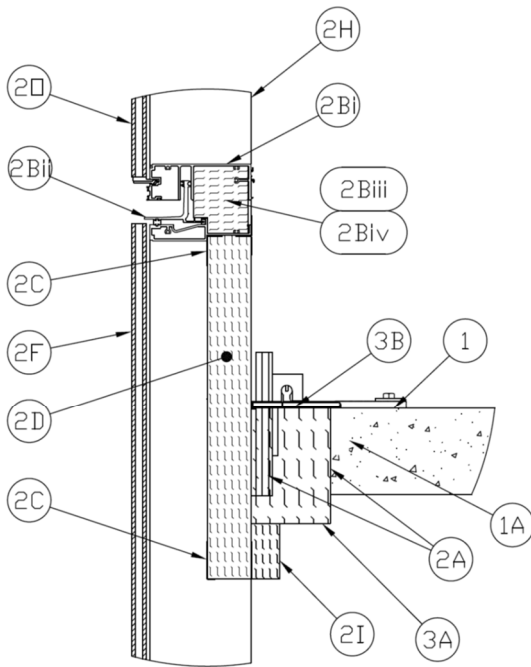

Figure 4 - Base Detail at Anchor (Top of Slab)

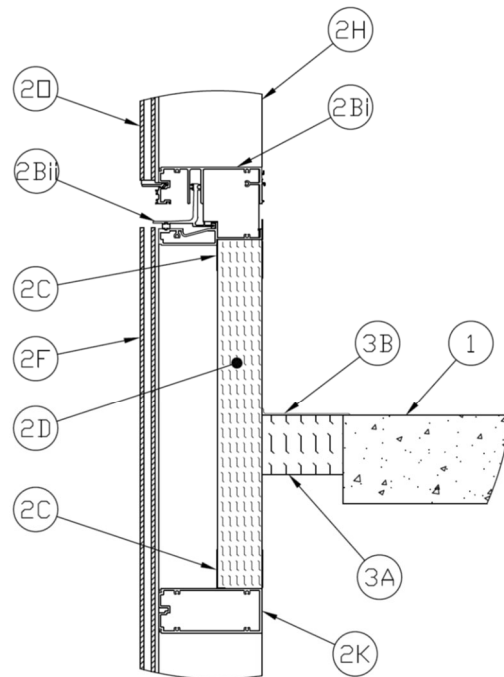

Figure 5 - Kiss Transom Configuration

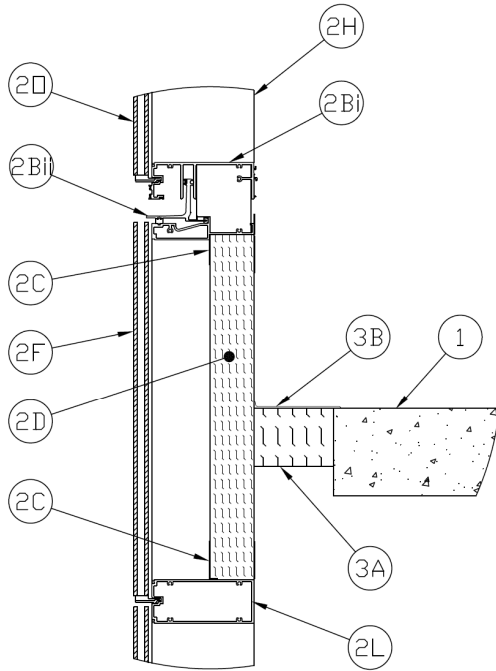

Figure 6 - Captured Transom Configuration

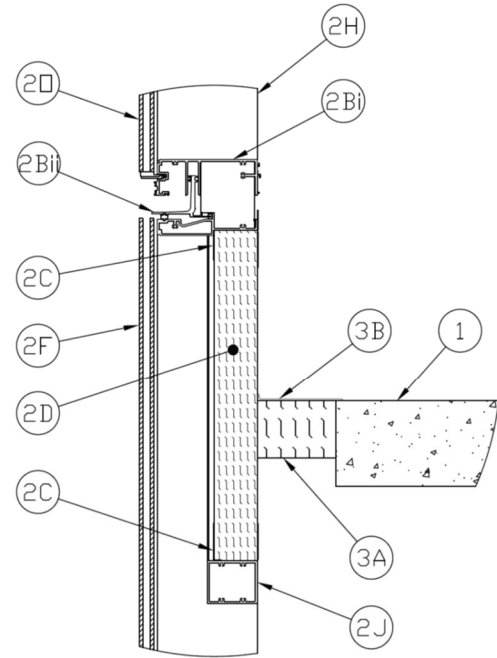

Figure 7 - Intermediate Transom with Shadowbox Configuration

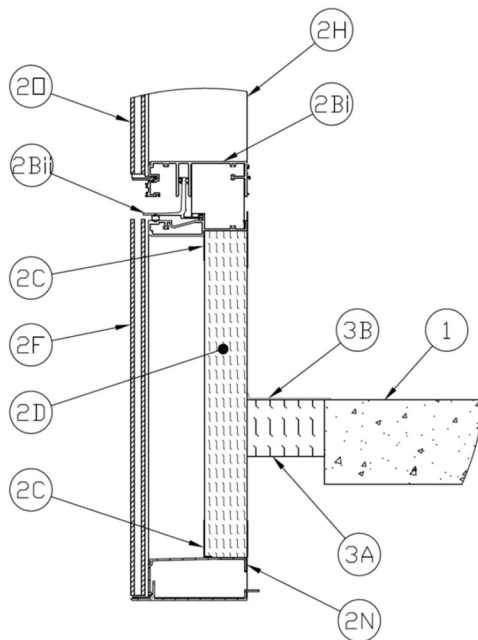

Figure 8 - Windload Anchor Configuration



1. **CONCRETE FLOOR ASSEMBLY:** Min, one-hour rated concrete floor assembly made from either lightweight or normal weight concrete with a density of 100-150 pcf, with a min. thickness of 6 in. (152 mm) at the joint face. F-rating will be determined by the rating of the concrete floor assembly system up to a max. 2-hr F-rating. For concrete floor assemblies with a rating of less than 2 hours, T-Rating shall be 0.

A. **STEEL EMBED:** For the mounting attachment (Item 2A) minimum 1-3/8 in. × 2 in., (35 mm × 51 mm) steel tube embeds with 7/8 in. (22 mm) slots on the front face are to be positioned at each mullion to accommodate the specific mounting attachment in accordance with the curtain wall assembly (Item 2) manufacturer's instructions. Embeds may be cast in place flush with the edge of the concrete floor assembly for face-of-slab anchors (Item 2Ai), or with the top surface of the concrete floor assembly for top-of-slab anchors (Item 2Aii) in accordance with the anchor manufacturer's installation instructions.

2. **CURTAIN WALL ASSEMBLY:** Construct the exterior wall assembly in compliance with applicable building codes and regulatory requirements. The core of the spandrel, comprised of all components noted in Items 2B through 2G, and 2I through 2N below, spans from a max. 12 in. (305 mm) above the concrete floor assembly (Item 1) to a min. 5-3/4 in. (146 mm) below the concrete floor assembly and must span a minimum 14-3/8 in. (365 mm). Other elements that exist within the spandrel and are marked optional are complimentary to

the design and shall be installed per the curtain wall manufacturer's design specifications.

A. **MOUNTING ATTACHMENT:** The mounting attachment may consist of one or more of the following types.

i. **FACE OF SLAB ANCHOR:** The face-mounted attachment consists of a one or two-piece, 1/2 in. (13 mm) thick, extruded aluminum faceplate with min 3/8 in. (9.5 mm) arms that form a "U" shape with corrugated surfaces serving as locking mechanisms for the horizontal adjustment feature. Corresponding washer plates with matching corrugations are used to house a steel cross bar where the mullion anchor hooks on to support the wall system vertically and horizontally. The height of the anchor plate is nominally 6 in. (152 mm) and may be positioned vertically on the edge of the concrete floor assembly (Item 1) from flush with the bottom to flush with the top of the concrete floor assembly. The mullion anchor plates are secured to the sides of the mullion, with interior edges flush with the interior face of the mullion, with steel bolts and nuts that engage with hardware internal to the mullion. The mullion anchor hook plate consists of a nominal 2 in. (51 mm) wide × 10.5 in. (267 mm) tall × 1/4 in. (6.4 mm) thick extruded aluminum plate with fist sliders that sit proud of the mullion face within the safing slot of the perimeter fire protection (Item 3). The



fist sliders receive min. 1/2 in. (12.7 mm) diameter jack bolts that are used to adjust the vertical position of the wall. The fist sliders may extend above the floor and up to 3 in. (76 mm) below the floor assembly (Item 1). The fist sliders may extend up to 1 in. (25 mm) below the packing material (Item 3A).

- ii. **TOP-OF-SLAB ANCHOR:** The top-of-slab anchor utilizes a 1/2-in. (13 mm) aluminum extruded plate measuring nominally 12 in. (305 mm) in width and 7.5 in. (191 mm) in length that spans across the top side of the perimeter joint protection (Item 3). The mullions are fitted with a hooked plate that mounts to the exterior side face of the mullion on both sides, using connecting hardware in accordance with the anchor manufacturer’s instructions.

B. **STACK JOINT** – The true stack joint consists of the Upper Transom (Item 2Bi) and the Anchor Head (Item 2Bii). The stack joint is adjustable, and the height of the stack joint may range from 4-3/16 in. (106 mm) in its fully closed position, to 5-7/16 in. (138 mm) in its fully open position. The max. gap between the Upper Transom (Item 2Bi) and the Anchor Head (Item 2Bii) is 1-1/4 in. (32 mm). The stack joint may incorporate a single or double chicken head in the design. The sill height between the top of the floor and the underside of the stack joint may be 2-5/8 in. to 12 in. (67 mm to 305 mm) for a single chicken head design or 0 in. to 12 in. (0 mm to 305 mm) for a double chicken

head design. The stack joint is to be insulated in accordance with the requirements stated in Table 1 below:

Sill Height Range (in.)	No. of Chicken Heads	Insulation Method for Stack Joint
2-5/8 to 5-1/2	1	Method 2Biii
Greater than 5-1/2 to 12	1	Method 2Bv
0 to 5-1/2	2	Method 2Biv
Greater than 5-1/2 to 12	2	No stack Insulation Required

Table 1. Stack Joint Insulation Details

- i. **UPPER TRANSOM:** The top of the upper transom is positioned directly above the anchor head transom (Item 2Bii) with mating connection points. The upper transom consists of nominal 1/8 in. (3 mm) extruded aluminum with an exterior wet chamber and interior profile that receives the “chicken head” from the anchor head extrusion (Item 2Bii), forming the stack joint. The front-to-back width of the upper transom is min. 7 in. (178 mm).
- ii. **ANCHOR HEAD:** The anchor head consists of nominal 1/8-in. (3 mm) thick extruded aluminum having a complex shape and a nominal 1-11/16 in. (43 mm) horizontal slot on the interior side of the transom, which may be left open



or, when a double chicken head design is used, may be enclosed. The height of the anchor head extrusion, from the bottom to the top of the “chicken head,” is nominally 4-3/16 in. (106 mm) and the width of the anchor head extrusion from front to back is 7 in. (178 mm). The anchor head contains a wet chamber on the exterior side and on the interior may be constructed with a single or double “chicken head” per the design of the manufacturer. The upper transom (Item 2Bi) and the anchor head engage at the stack joint.

- iii. **CERTIFIED MANUFACTURER:**
Thermafiber

CERTIFIED PRODUCT: Mineral Wool

CERTIFIED MODEL: Safing

PACKING MATERIAL (ANCHOR HEAD CAVITY INSULATION): (For single chicken head design) Inside the anchor head cavity, install minimum 4 pcf (64 kg/m³) density mineral wool batt insulation in the cavity space, compressed at minimum 25% compression, for a minimum distance of 12 in. (305 mm) on each side of every mullion. The insulation is to be friction-fitted into place, extending the full height of the anchor head cavity and flush with the interior of the anchor head slot. If a double chicken head is utilized, this step is optional but the

Trough Insulation (Item 2Biv) would then be required.

- iv. **CERTIFIED MANUFACTURER:**
Thermafiber

CERTIFIED PRODUCT: Mineral Wool

CERTIFIED MODEL: Safing

PACKING MATERIAL (TROUGH INSULATION): (For double chicken head design) If a double chicken head is utilized in the design, Packing Material (Item 2Biii) is optional. Inside the anchor head trough between the chicken heads, install minimum 4 pcf (64 kg/m³) density mineral wool cut to a length of 6 in. (152 mm). The mineral wool is to be centered over the joint between adjacent panels and extended to a minimum 3 in. (76 mm) on each side of the joint. The insulation is to be friction-fitted into place between the chicken heads and installed uncompressed to the full height of the anchor head cavity. The insulation will receive compression from the upper transom when the upper panels are installed.

- v. **CERTIFIED MANUFACTURER:**
Thermafiber

CERTIFIED PRODUCT: Mineral Wool

CERTIFIED MODEL: Safing



PACKING MATERIAL (TROUGH INSULATION): (For single chicken head design) Inside the anchor head cavity, install minimum 4 pcf (64 kg/m³) density mineral wool batt insulation in the cavity space, compressed at minimum 25% compression, for a minimum distance of 3 in. (76 mm) on each side of every mullion. The insulation is to be friction-fitted into place, extending the full height of the anchor head cavity and flush with the interior of the anchor head slot.

C. CURTAINWALL INSULATION RETAINING

SYSTEM: Specified Technologies, Inc. SpecSeal® QuickClip™ is an insulation retaining clip system that is required to secure the curtainwall insulation (Item 2D) to the spandrel, using brackets made from 20 GA steel. There are 3 styles of brackets which are U-shaped, Z-Shaped, and L-shaped. Install at least one bracket on each mullion below the floor assembly, located a max. of 9-1/4 in. (235 mm) under the bottom of the floor. Additional brackets used below the first bracket below the floor are spaced no more than 20-3/4 in. (527 mm) on-center (oc). When the curtainwall insulation (Item 2D) extends above the perimeter joint (Item 3), install additional clips as follows. For all clips used on the mullion above the lower clip, install with spacing not to exceed 15-1/4 in. (387 mm) oc. On stack joint transoms, install Z or L shaped brackets spaced no more than 6 in. (152 mm) from the mullion, no more than 6 in. (152 mm) on both sides of a vertical seam

of the curtainwall insulation (Item 2D), and no more than 23 in. (584 mm) oc. For mullion spans wider than 37-1/4 in. (946 mm), sufficient brackets are installed to maintain the max. allowed spacing. Brackets are secured using a single 1/2 in. (12.7 mm) No. 10 self-tapping screw. Use a SpecSeal® QuickClip™ fastener, which is a staple-shaped steel fastener that penetrates the insulation and interlocks with the bracket, to secure the insulation. Brackets are installed onto mullions or transoms per the manufacturer's instructions. The 3 styles of brackets are detailed below:

- i. **U-SHAPED STEEL BRACKET:** Specified Technologies, Inc. SpecSeal® QuickClip™ U-shaped brackets support curtainwall insulation on both sides of the mullion simultaneously. They are secured to the interior face of mullions (Item 2H) and cannot be used on the stack joint transom (Item 2B). They may be used in tandem with other U-shaped brackets, Z-shaped brackets (Item 2Cii), or L-shaped brackets (Item 2Ciii). U brackets used to support a steel stiffener must only be paired with other U brackets or Z brackets.
- ii. **Z-SHAPED STEEL BRACKET:** Specified Technologies, Inc. SpecSeal® QuickClip™ Z-shaped brackets are installed on the left and right sides of the mullion, located and spaced as required. They may be secured to the interior face or side face of the mullion



(Item 2H), or the underside or interior side of the anchor head transom (Item 2Bii). They may be used in tandem with other Z-shaped brackets, U-shaped brackets (Item 2Ci), or L-shaped brackets (Item 2Ciii). Z brackets used to support a steel stiffener must only be paired with other Z brackets or U brackets.

- iii. **L-SHAPED STEEL BRACKET:** Specified Technologies, Inc. SpecSeal® QuickClip™ L-shaped brackets are installed on the left and right sides of the mullion, located and spaced as required. They are secured to the side face of mullions (Item 2H) or underside of the anchor head transom (Item 2Bii). They may be used in tandem with other L-shaped brackets, U-shaped brackets (Item 2Ci), or Z-shaped brackets (Item 2Cii). L brackets must only be paired with other L brackets when they are supporting a steel stiffener.

D. CERTIFIED MANUFACTURER: Thermafiber

CERTIFIED PRODUCT: Mineral Wool

CERTIFIED MODEL: Firespan 90

CURTAINWALL INSULATION: Install minimum 3 in. (76 mm) thick 8 pcf (128 kg/m³) density mineral wool with foil-scrim facing on the interior side into the spandrel, flush with the interior side of the mullions. Insula on bat is to be butted up to the underside of the anchor head transom and

friction fit between the mullions with a minimum 1/8 in. (3 mm) over-cut on the spandrel width. The insulation is to extend from the underside of the anchor head transom downward in the spandrel cavity a minimum 15-3/4 in. (400 mm). The curtainwall insulation is to be secured with the Curtainwall Insulation Retaining System (Item 2C). The curtainwall insulation is not required to terminate at a lower transom. Space below the curtainwall insulation and the next lower transom may be left void or filled with alternative insulative materials (Item 2E). A max. of one vertical seam is allowed in the spandrel. When a vertical seam is required, the seam is to be bridged with a mullion cover (Item 2I) below the floor.

E. ALTERNATIVE INSULATIVE MATERIALS

(Optional): In any space that exists below the curtainwall insulation (Item 2D), where insulation is required for energy conservation requirements or other purposes, the space may be filled with any material that complies with applicable building code and regulatory requirements.

F. EXTERIOR SPANDREL CLADDING:

Install glazing or an exterior cladding system that complies with applicable building code and regulatory requirements. Install in accordance with the exterior curtain wall assembly manufacturer's instructions and the design specifications. Glazing panels or other specified cladding may be secured in position with aluminum pressure plates in conjunction with glazing gaskets and steel



screws or with structural silicone installed in accordance with the manufacturer's instructions.

G. **SHADOW BOX:** (Optional) A shadow box installed on the exterior side of the curtainwall insulation (Item 2D) may be formed of any material that complies with applicable building code and regulatory requirements. Install in accordance with the exterior curtain wall assembly manufacturer's instructions and the design specifications.

H. **VERTICAL MULLIONS:** Vertical mullions are constructed of nominal 1/8 in. (3 mm) extruded aluminum. Mullions can be constructed as solid members, or as joining members that are split vertically. Mullions are designed with a wet chamber on the exterior side and a dry chamber on the interior side. Mullions have a minimum depth of 7 in. (178 mm) and a minimum width of 3 in. (76 mm). Spacing of the mullions is min. 18 in. (46 cm) oc and max. 63 in. (160 cm) oc. The span between mullions may not exceed 60 in. (152 cm).

i. **MULLION PLUG:** (Not Shown) When a true stack joint is present, a Specified Technologies, Inc. SpecSeal® Mullion Plug must be applied within the dry cavity of the mullion, with the top edge of the mullion foam flush with the top of the floor and with the intumescent side of the plug facing downward. The plug shall be cut to match the profile of the mullion cavity it is placed in and

sized slightly larger than the cavity as to fully fill the space and form a friction fit.

ii. **CERTIFIED MANUFACTURER:**
Thermafiber

CERTIFIED PRODUCT: Mineral Wool

CERTIFIED MODEL: Firespan 40 or Firespan 90

MULLION FILLER: (Not Shown) Any dry cavity space that exists at the floor level that cannot be filled with a mullion plug (Item 2H), must be filled with 4 pcf (64 kg/m³) density mineral wool, loosely packed into the cavity space.

I. **CERTIFIED MANUFACTURER:** Thermafiber

CERTIFIED PRODUCT: Mineral Wool

CERTIFIED MODEL: Firespan 90

MULLION COVERS: Install minimum 2 in. (51 mm) thick 8 pcf (128 kg/m³) density mineral wool with foil-scrim facing on the interior side over the vertical mullion (Item 2H) or any vertical seam in the curtainwall insulation (Item 2D) on the interior side of the wall below the floor assembly (Item 1). The mullion cover is to be centered on the mullion or over the seam and shall extend a minimum 3-1/2 in. (89 mm) on each side of the mullion or seam and vertically extend from below the packing material (Item 3A) to the bottom of the curtainwall insulation (Item 2D). Secure the mullion cover to the curtainwall insulation with 4, steel spiral



anchors that extend a minimum of 1 in. (25 mm) into the curtainwall insulation and are to be located in the corners of the plugs, a minimum of 1 in. from the edges. Aluminum foil tape may be used to seal the mullion cover edges to the curtainwall insulation but is not required.

- J. **INTERMEDIATE TRANSOM:** (Optional) An intermediate transom may be installed on the underside of the curtainwall insulation (Item 2D) and may be formed of any material that complies with applicable building code and regulatory requirements. Install in accordance with the exterior curtain wall assembly manufacturer's instructions and the design specifications.
- K. **CONTINUOUS GLAZING FRAME (KISS TRANSOM):** (Optional) A continuous glazing frame (Kiss Transom) may be installed below the curtainwall insulation (Item 2D) and may be formed of any material that complies with applicable building code and regulatory requirements. Install in accordance with the exterior curtain wall assembly manufacturer's instructions and the design specifications.
- L. **CAPTURED TRANSOM:** (Optional) A captured transom that utilizes either aluminum pressure plates in conjunction with glazing gaskets and steel screws or with structural silicone installed in accordance with the manufacturer's instructions may be installed below the curtainwall insulation (Item 2D) and may be formed of any material that complies with

applicable building code and regulatory requirements. Install in accordance with the exterior curtain wall assembly manufacturer's instructions and the design specifications.

- M. **ARCHITECTURAL COVER:** (Optional, Not Shown) An architectural cover that hides the perimeter joint protection (Item 3) may be installed in accordance with the exterior curtain wall assembly manufacturer's instructions and the design specifications.
 - N. **WINDLOAD ANCHOR:** (Optional) A windload anchor may be installed on the underside of the curtainwall insulation (Item 2D) and may be formed of any material that complies with applicable building code and regulatory requirements. Install in accordance with the exterior curtain wall assembly manufacturer's instructions and the design specifications.
 - O. **VISION PANELS:** Vision panels are to be in compliance with exterior curtain wall assembly (Item 2) design specifications. Glazing panels may be secured in position with aluminum pressure plates in conjunction with glazing gaskets and steel screws or with structural silicone installed in accordance with the manufacturer's instructions.
3. **PERIMETER JOINT PROTECTION:** The perimeter joint (linear opening) is not to exceed 3-3/8 in. (86 mm) nominal joint width (joint width at installation). The perimeter joint treatment shall incorporate the following construction features:



A. **CERTIFIED MANUFACTURER:** Thermafiber

CERTIFIED PRODUCT: Mineral Wool

CERTIFIED MODEL: Safing

PACKING MATERIAL: Install a minimum 4 in. (102 mm) depth, as measured vertically from the top of the floor, of 4 pcf (64 kg/m³) density mineral wool batt insulation installed with the fibers running parallel to the floor assembly edge and curtainwall. Divide the nominal joint width by 0.75 to provide the width of mineral wool to be cut and installed to produce the required min. 25% compression in the nominal joint width. Install the batt insulation into the perimeter joint flush with the top surface of the concrete floor assembly (Item 1). Splices (butt joints) in the lengths of mineral wool batt insulation are to be tightly compressed together. In locations around every face mounted attachment (Item 2Ai) increase the depth of mineral wool to a min. 8 in. (203 mm) to provide a min. 2 in. (51 mm) protective layer under the mounting attachment. This increased depth is to be applied for a min. horizontal distance of 2 in. (51 mm) on both sides of the mounting attachment. For any exposed surface of the mounting attachment flush with the top of

the joint, install a minimum 3/4 in. (19 mm) layer of packing material over the mounting attachment for the width of the joint. The cover requires no attachment and is to extend a min. 2 in. (51 mm) on each side of the exposed mounting attachment. No cover is required for mounting attachment elements that extend above the surface of the packing material.

B. **CERTIFIED MANUFACTURER:** Specified Technologies, Inc.

CERTIFIED PRODUCT: Joint Sealant Spray

CERTIFIED MODEL: SpecSeal® AS200 Series Elastomeric Firestop Spray, or SpecSeal® Fast Tack® Firestop Spray

FILL VOID OR CAVITY MATERIAL: Apply a minimum wet film thickness of 1/8 in. (3.2 mm) over the packing material (Item 3A) and overlap the liquid spray material a minimum 1/2 in. (12.7 mm) onto the interior surface of the adjacent curtain wall assembly (Item 2) and the concrete floor assembly (Item 1). If the spraying process is stopped and the applied liquid spray material cures to an elastomeric film before the process is restarted, then overlap the edge of the cured spray material at least 1/8 in. (3.2 mm) with the liquid spray material.



Consult the listing report on the Directory of Building Products (<https://bpdirectory.intertek.com>) for the edition of the standard(s) evaluated.

Compliance of the assembly described in this Design Listing with the referenced standard relies on verification that the assembly constructed in the field is consistent with that described herein. Intertek certified products may be verified by the approved Intertek label; other products must be verified by the Authority Having Jurisdiction as meeting the specifications stated herein.