

Specified Technologies, Inc.
Design No. STI/BPF 120-53
Perimeter Fire Barrier System – Curtain Wall Assembly
SpecSeal® AS200 Series Elastomeric Spray
SpecSeal® Fast Tack® Firestop Spray
ASTM E2307, CAN/ULC-S115
Rating: F-Rating – 2 hr.
UL 2079 L-Rating < 2 SCFM/LF
Movement Type = Class IV
Rated for ± 5% Vertical Movement at 25% Compression (Item 3A)

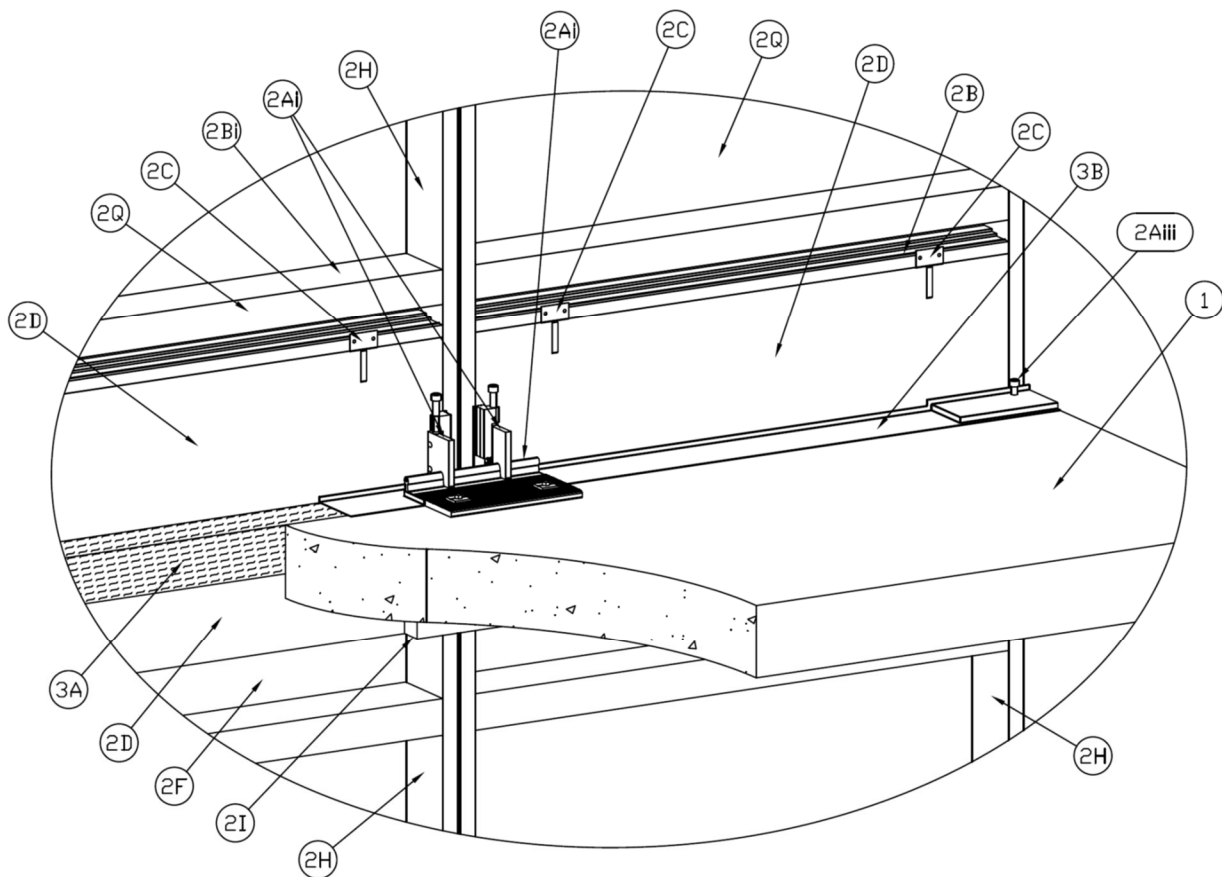

Figure 1 - Isometric with Interior Vertical Mullion Detail

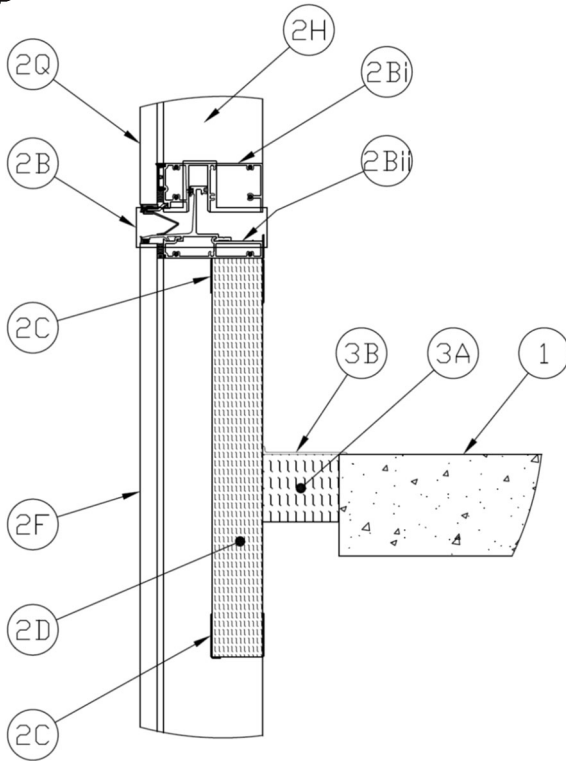

Figure 2 - Base Detail Between Anchors

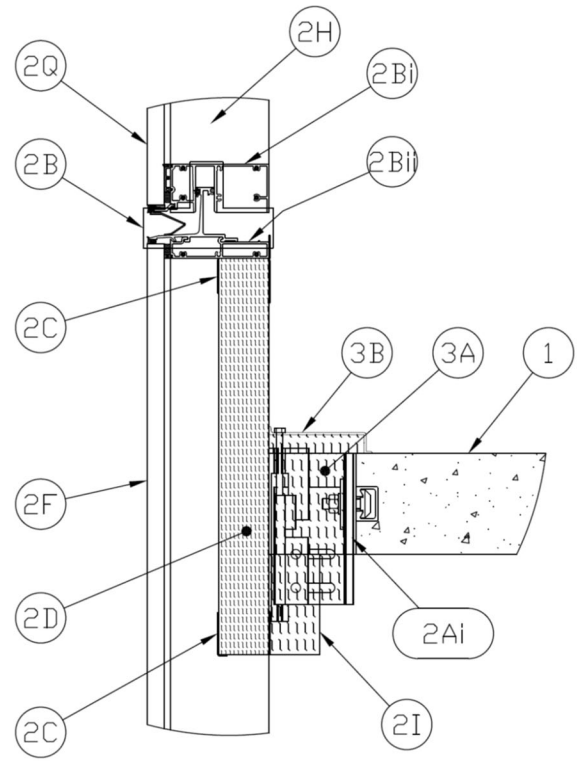

Figure 3 - Base Detail at Anchor (Face of Slab)

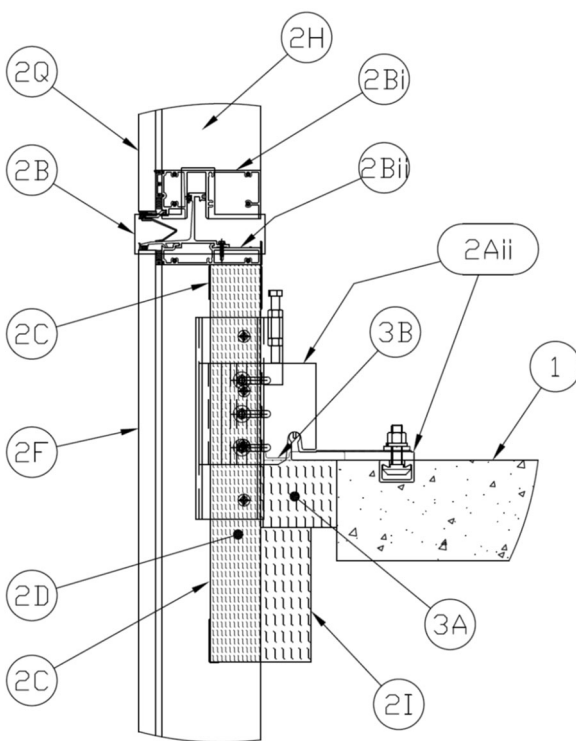

Figure 4 - Base Detail at Anchor (Top of Slab)

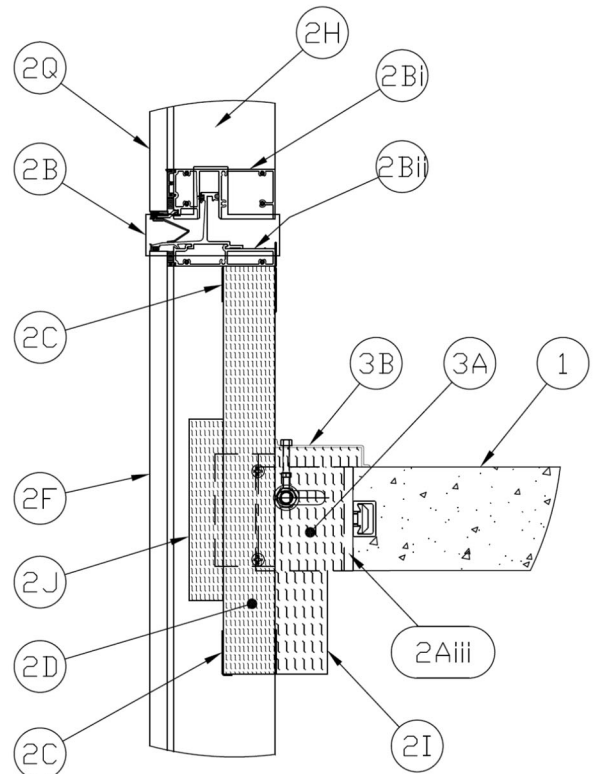

Figure 5 - Base Detail at Anchor (Jamb)

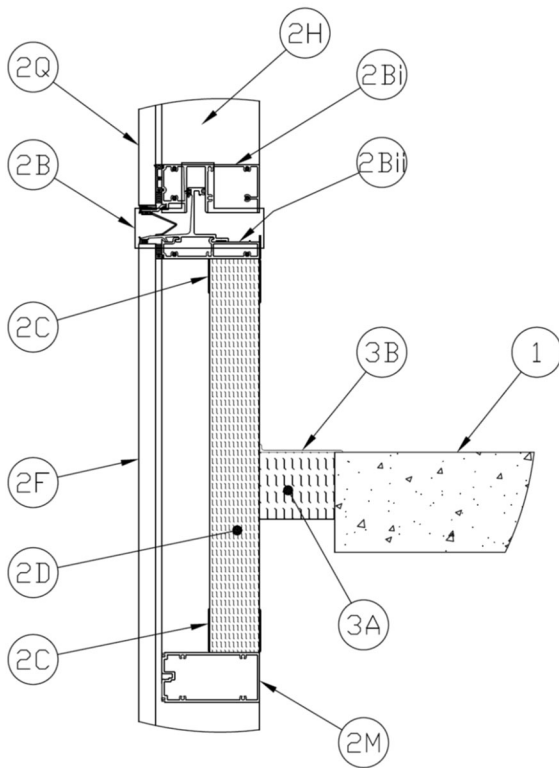

Figure 6 - Kiss Transom Configuration

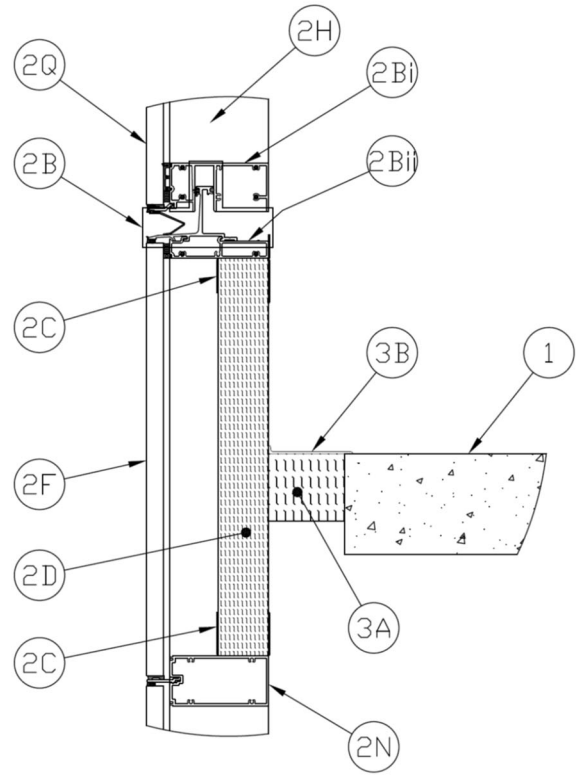

Figure 7 - Captured Transom Configuration

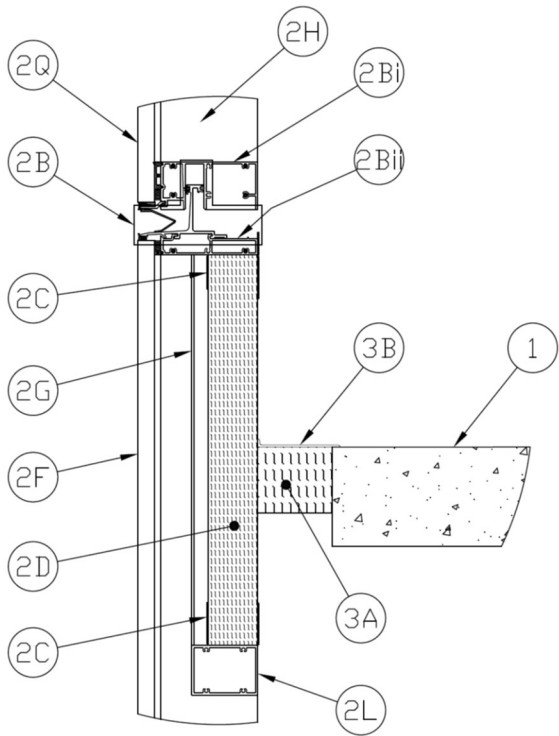

Figure 8 - Intermediate Transom with shadowbox Configuration

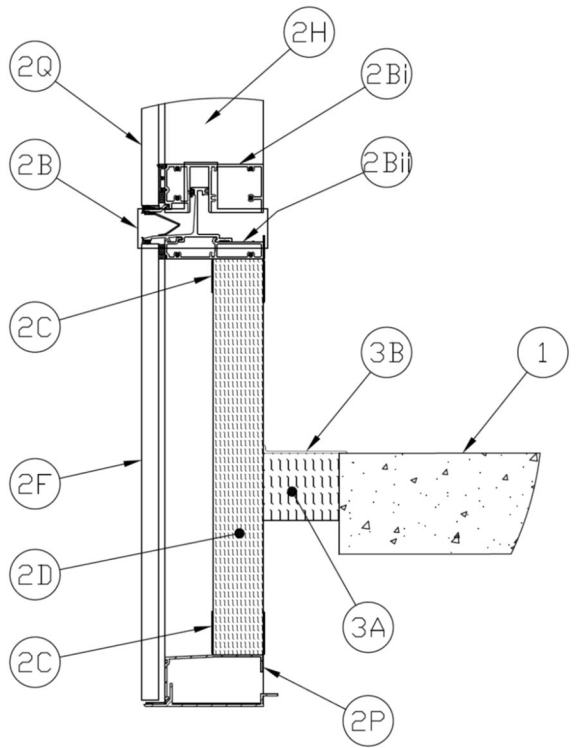

Figure 9 - Windload Anchor Configuration



1. CONCRETE FLOOR ASSEMBLY: Minimum one-hour rated concrete floor assembly made from either lightweight or normal weight concrete with a density of 100-150 pcf, with a minimum thickness of 6 in. (152 mm) at the joint face. F-rating will be determined by the rating of the concrete floor assembly system up to a maximum 2-hr F-rating. For concrete floor assemblies with a rating of less than 2 hours, T-Rating shall be 0.

A. **STEEL EMBED:** For the mounting attachment (Item 2A) minimum 1-3/8 in. × 2 in., (35 mm × 51 mm) steel tube embeds with 7/8 in. (22 mm) slots on the front face are to be positioned at each mullion to accommodate the specific mounting attachment (Item 2A) in accordance with the curtain wall assembly (Item 2) manufacturer's instructions. Embeds may be cast in place flush with the edge of the concrete floor assembly for jamb anchors (Item 2Aii), or with the top surface of the concrete floor assembly for top-of-slab anchors (Item 2Ai) in accordance with the anchor manufacturer's installation instructions.

2. CURTAIN WALL ASSEMBLY: Construct the exterior wall assembly in compliance with applicable building codes and regulatory requirements. The core of the spandrel, comprised of all components noted in Items 2C through 2G and 2I through 2P below, spans from a maximum 12 in. (305 mm) above the concrete floor assembly to a minimum 6-1/2 in. (165 mm) below the concrete floor assembly and must span a minimum 18 in. (457 mm) top to bottom.

Other elements within Item 2 that exist within the spandrel and are marked optional are complimentary to the design and shall be installed per the curtain wall manufacturer's design specifications.

- A. **MOUNTING ATTACHMENT:** The mounting attachment may consist of one or more of the following types.
- i. **FACE OF SLAB ANCHOR:** The face-mounted attachment consists of twin, L-shaped brackets installed back-to-back, with the 1/2-in. (13-mm) extruded aluminum mounting face secured to the embed slot with T bolt fasteners. The blade of the anchor, perpendicular to the slab edge, is formed of 3/8-in. (9.5 mm) thick aluminum and extends into a 2-1/8 in. (54 mm) wide × 11-3/4 in. (298 mm) tall slot in the interior face of the mullion. The blade accommodates connecting hardware that supports a hooked plate that is attached to the interior of the mullion and exits through the mullion slot. When this anchor is used, an intumescent foam mullion plug (Item 2M) is installed so the top of the foam plug is flush with the top of the mullion slot with the intumescent pad positioned on the bottom of the mullion plug.
 - ii. **TOP-OF-SLAB ANCHOR:** The top-of-slab anchor utilizes a 1/2-in. (13-mm) aluminum extruded plate measuring nominally 12 in. (305 mm) in width and 7-1/2 in. (191 mm) in length that spans



across the top side of the perimeter joint protection (Item 3). The mullions are fitted with a hooked plate that mounts to the exterior side face of the mullion on both sides, using connecting hardware in accordance with the anchor manufacturer’s instructions.

- iii. **JAMB ANCHOR:** The jamb anchor, used primarily at building corners and terminations, is formed using twin, U-shaped, extruded aluminum shapes 1/2-in. (13 mm) in thickness. These are inverted, facing each other within the safing slot with one plate mounted to the face-of-slab embeds using T-bolts, and the other mounted to one side of the mullion. The face-mounted plate accommodates a “monkey bar” between the U-Shaped bracket, and a hooked plate is mounted to the exterior side U-shaped bracket which engages with the monkey bar to support the wall system. The jamb anchor face-mounted U-shaped bracket is 6 in. (152 mm) tall and may be mounted at any vertical position on the concrete floor assembly edge, flush with the top or bottom of the concrete floor assembly, or anywhere vertically in between. The exterior U-shaped bracket is 6.5 in. (165 mm) tall and the underside of the anchor may be positioned up to 1/4 in. (6 mm) or anywhere above that position. When the jamb anchor is used, and the exterior U-shaped bracket extends beyond the outer surface of the curtainwall insulation (Item 2F), the

bracket face must be covered with the exterior jamb anchor protection (Item 2L).

- B. **STACK JOINT:** The true stack joint consists of the Upper Transom (Item 2Bi) and the Anchor Head (Item 2Bii). The stack joint is adjustable, and the height of the stack joint may range from 4-3/8 in. (111 mm) in its fully closed position, to 5-5/8 in. (143 mm) in its fully open position. The maximum gap between the Upper Transom (Item 2Bi) and the Anchor Head (Item 2Bii) is 1-1/4 in. (32 mm). The stack joint may incorporate a single or double chicken head in the design. The sill height between the top of the floor and the underside of the stack joint may be 2-5/8 in. to 12 in. (66 mm to 305 mm) for a single chicken head design or 0 in. to 12 in. (0 mm to 305 mm) for a double chicken head design. The stack joint is to be insulated in accordance with the requirements stated in the table below:

Sill Height Range (in.)	No. of Chicken Heads	Insulation Method for Stack Joint
2-5/8 to 5-1/2	1	Method 2Biv
Greater than 5-1/2 to 12	1	Method 2Bv
0 to 5-1/2	2	Method 2Biii
Greater than 5-1/2 to 12	2	No stack Insulation Required

Table 1. Stack Joint Insulation Details



- i. UPPER TRANSOM: The upper transom consists of nominal 1/8 in. (3 mm) extruded aluminum with an exterior wet chamber and interior geometry that receives the “chicken head” from the anchor head extrusion (Item 2C), forming the stack joint. The front-to-back width of the upper transom is minimum 5-7/8 in. (149 mm).
- ii. ANCHOR HEAD: The anchor head consists of nominal 1/8 in. (3 mm) thick extruded aluminum having a complex shape and a nominal 1-11/16 in. (43 mm) × 2-1/8 in. (48 mm) slot on the interior side of the transom. The height of the anchor head extrusion, from the bottom to the top of the “chicken head,” is nominally 4-1/4 in. (108 mm) and the width from front to back is 5-7/8 in. (149 mm). The anchor head contains a wet chamber on the exterior side and on the interior may be constructed with a single or double “chicken head” per the design of the manufacturer. The upper transom (Item 2B) and the anchor head engage at the stack joint and the bottom of the anchor head extrusion is positioned 0 in. to 12 in. (0 mm to 305 mm) above the top of the concrete floor assembly surface.

iii. **CERTIFIED MANUFACTURER:**
Thermafiber

CERTIFIED PRODUCT: Mineral Wool

CERTIFIED MODEL: Safing

PACKING MATERIAL (TROUGH INSULATION): (For double chicken head design) Inside the anchor head trough between the chicken heads, install minimum 4 pcf (64 kg/m³) density mineral wool cut to a length of 6 in. (152 mm). The mineral wool is to be centered over the joint between adjacent panels and extended to a minimum 3 in. (76 mm) on each side of the joint. The insulation is to be friction-fitted into place between the chicken heads and installed uncompressed to the full height of the anchor head cavity. The insulation will receive compression from the upper transom when upper panels are installed.

iv. **CERTIFIED MANUFACTURER:**
Thermafiber

CERTIFIED PRODUCT: Mineral Wool

CERTIFIED MODEL: Safing

PACKING MATERIAL (ANCHOR HEAD CAVITY INSULATION): (For single chicken head design) Inside the anchor head cavity, install minimum 4 pcf (64 kg/m³) density mineral wool batt insulation in the cavity space, compressed at minimum 25% compression, for a minimum distance of 12 in. (305 mm) on each side of every mullion. The insulation is to be friction-fitted into place, extending the full



height of the anchor head cavity and flush with the interior of the anchor head slot.

- v. **CERTIFIED MANUFACTURER:**
Thermafiber

CERTIFIED PRODUCT: Mineral Wool

CERTIFIED MODEL: Safing

PACKING MATERIAL (TROUGH INSULATION): (For single chicken head design) Inside the anchor head cavity, install minimum 4 pcf (64 kg/m³) density mineral wool batt insulation in the cavity space, compressed at minimum 25% compression, for a minimum distance of 3 in. (76 mm) on each side of every mullion. The insulation is to be friction-fitted into place, extending the full height of the anchor head cavity and flush with the interior of the anchor head slot.

- C. **CURTAINWALL INSULATION RETAINING SYSTEM:** Specified Technologies, Inc. SpecSeal® QuickClip™ is an insulation retaining clip system that is required to secure the curtainwall insulation (Item 2F) to the spandrel, using brackets made from 20 GA steel. There are 3 styles of brackets which are U-shaped, Z-Shaped, and L-shaped. Install at least one bracket on each mullion below the floor assembly, located a max. of 9-1/4 in. (235 mm) under the bottom of the floor. Additional brackets used below the first bracket below the floor

are spaced no more than 20-3/4 in. (527 mm) on-center (oc). When the curtainwall insulation (Item 2D) extends above the perimeter joint (Item 3), install additional clips as follows. For all clips used on the mullion above the lower clip, install with spacing not to exceed 15-1/4 in. (387 mm) oc. On stack joint transoms, install Z or L shaped brackets spaced no more than 6 in. (152 mm) from the mullion, no more than 6 in. (152 mm) on both sides of a vertical seam of the curtainwall insulation (Item 2D), and no more than 23 in. (584 mm) oc. For mullion spans wider than 37-1/4 in. (946 mm), sufficient brackets are installed to maintain the max. allowed spacing. Brackets are secured using a single 1/2 in. (12.7 mm) No. 10 self-tapping screw. Use a SpecSeal® QuickClip™ fastener, which is a staple-shaped steel fastener that penetrates the insulation and interlocks with the bracket, to secure the insulation. Brackets are installed onto mullions or transoms per the manufacturer's instructions. The 3 styles of brackets are detailed below.

- i. **U-SHAPED STEEL BRACKET:** Specified Technologies, Inc. SpecSeal® QuickClip™ U-shaped brackets support curtainwall insulation on both sides of the mullion simultaneously. They are secured to the interior face of mullions (Item 2J) and cannot be used on the stack joint transom (Item 2B). They may be used in tandem with other U-shaped brackets, Z-shaped brackets (Item 2D-ii), or L-shaped brackets (Item 2D-iii). U



brackets used to support a steel stiffener must only be paired with other U brackets or Z brackets.

- ii. **Z-SHAPED STEEL BRACKET:** Specified Technologies, Inc. SpecSeal® QuickClip™ Z-shaped brackets are installed on the left and right sides of the mullion, located and spaced as required. They may be secured to the interior face or side face of the mullion (Item 2J), or the underside or interior side of the anchor head transom (Item 2C). They may be used in tandem with other Z-shaped brackets, U-shaped brackets (Item 2D-i), or L-shaped brackets (Item 2D-iii). Z brackets used to support a steel stiffener must only be paired with other Z brackets or U brackets.
- iii. **L-SHAPED STEEL BRACKET:** Specified Technologies, Inc. SpecSeal® QuickClip™ L-shaped brackets are installed on the left and right sides of the mullion, located and spaced as required. They are secured to the side face of mullions (Item 2J) or underside of the anchor head transom (Item 2C). They may be used in tandem with other L-shaped brackets, U-shaped brackets (Item 2D-i), or Z-shaped brackets (Item 2D-ii). L brackets must only be paired with other L brackets when they are supporting a steel stiffener.

D. CERTIFIED MANUFACTURER: Thermafiber

CERTIFIED PRODUCT: Mineral Wool

CERTIFIED MODEL: Firespan 90

CURTAINWALL INSULATION: Install minimum 3 in. (76 mm) thick 8 pcf (128 kg/m³) density mineral wool with foil-scrim facing on the interior side into the spandrel, flush with the interior side of the mullions. Insulation batt is to be butted up to the underside of the anchor head transom and friction fits between the mullions with a minimum 1/8 in. (3 mm) over-cut on the spandrel width. The insulation is to extend from the underside of the anchor head transom downward in the spandrel cavity a minimum 18 in. (457 mm). The curtainwall insulation is to be secured with the Curtainwall Insulation Retention System (Item 2D). The curtainwall insulation is not required to terminate at a lower transom. Space below the curtainwall insulation between the bottom of the insulation and the next lower transom may be left void or filled with alternative insulation materials (Item 2G). A maximum of one vertical seam is allowed in the spandrel. When a vertical seam is required, the seam is to be bridged with a mullion cover (Item 2I) below the floor.

- E. **ALTERNATIVE INSULATIVE MATERIALS:** (Optional, Not Shown) In any space that exists below the curtainwall insulation (Item 2F), where insulation is required for energy conservation requirements or other purposes, the space may be filled with any



material that complies with applicable building code and regulatory requirements.

F. EXTERIOR SPANDREL CLADDING:

(Optional) Install glazing or an exterior cladding system that complies with applicable building code and regulatory requirements. Install in accordance with the exterior curtain wall assembly manufacturer's instructions and the design specifications. Glazing panels or other specified cladding may be secured in position with aluminum pressure plates in conjunction with glazing gaskets and steel screws or with structural silicone installed in accordance with the manufacturer's instructions.

G. SHADOW BOX: (Optional, Not Shown) A shadow box installed on the exterior side of the curtainwall insulation (Item 2F) may be formed of any material that complies with applicable building code and regulatory requirements. Install in accordance with the exterior curtain wall assembly manufacturer's instructions and the design specifications.

H. VERTICAL MULLIONS: Vertical mullions are constructed of nominal 1/8 in. (3 mm) extruded aluminum. Mullions can be constructed as solid members, or as joining members that are split vertically. Mullions are designed with a wet chamber on the exterior side and a dry chamber on the interior side. Mullions have a minimum depth of 5-7/8 in. (149 mm) and a minimum width of 3 in. (76 mm). Spacing of the

mullions is minimum 18 in. (457 mm) oc and maximum 63-1/2 in. (161 cm) oc. The span between mullions may not exceed 60 in. (152 cm).

I. CERTIFIED MANUFACTURER: Thermafiber

CERTIFIED PRODUCT: Mineral Wool

CERTIFIED MODEL: Firespan 90

MULLION COVERS: Install minimum 2 in. (51 mm) thick 8 pcf (128 kg/m³) density mineral wool with foil-scrim facing on the interior side over the vertical mullion or any vertical seam in the curtainwall insulation (Item 2D) on the interior side of the wall below the concrete floor assembly (Item 1). The mullion cover is to be centered on the mullion and extend a minimum 3-1/2 in. (89 mm) on each side of the mullion and vertically extend from below the packing material (Item 3A) to the underside of the curtainwall insulation (Item 2F). Secure the mullion cover to the curtainwall insulation with 4 steel spiral anchors that extend a minimum 1 in. (25 mm) into the curtainwall insulation and are to be located in the corners of the covers, a minimum of 1 in. from the edges. Aluminum foil tape may be used to seal the mullion cover edges to the curtainwall insulation but is not required. The mullion cover may extend to the underside of the curtainwall insulation (Item 2F) but must extend a minimum 6-1/2 in. (165 mm) below the concrete floor assembly (Item 1).



J. CERTIFIED MANUFACTURER: Thermafiber

CERTIFIED PRODUCT: Mineral Wool

CERTIFIED MODEL: Firespan 90

EXTERIOR JAMB ANCHOR PROTECTION:

(Not Shown): Where the jamb anchor U-shaped bracket extends beyond the curtainwall insulation, install minimum 2 in. (51 mm) thick 8 pcf (128 kg/m³) density mineral wool with foil-scrim facing on the interior side over the face of the U-shaped bracket so that it is protected a minimum 2 in. (51 mm) on each side. Hollow out the shape of the U-shaped bracket plate face to the depth at which it extends past the curtainwall insulation (Item 2F) so the face of the insulation sits with no gap to the exterior side of the curtainwall insulation and the bracket is protected with minimum 1.5 in. (38 mm) of insulation. Secure the bracket cover to the curtainwall insulation with steel spiral anchors that extend a minimum 1 in. (25 mm) into the curtainwall insulation. Aluminum foil tape may be used to seal the mullion cover edges to the curtainwall insulation but is not required.

K. FRAMING FILL: When the face-of-slab anchor (Item 2Ai) is used, insert a Specified Technologies, Inc. SpecSeal[®] Mullion Plug into the core of the mullion so the top of the mullion plug is flush with the top of the anchor slot in the mullion, with the intumescent pad positioned on the bottom of the mullion plug. Plug shall be cut to match the profile of the mullion cavity it is placed in and sized slightly larger than the

cavity as to fully fill the space and form a friction fit.

L. INTERMEDIATE TRANSOM: (Optional, Not Shown) An intermediate transom may be installed on the underside of the curtainwall insulation (Item 2F) and may be formed of any material that complies with applicable building code and regulatory requirements. Install in accordance with the exterior curtain wall assembly manufacturer's instructions and the design specifications.

M. CONTINUOUS GLAZING FRAME (KISS TRANSOM): (Optional, Not Shown) A continuous glazing frame (Kiss Transom) may be installed below the curtainwall insulation (Item 2F) and may be formed of any material that complies with applicable building code and regulatory requirements. Install in accordance with the exterior curtain wall assembly manufacturer's instructions and the design specifications.

N. CAPTURED TRANSOM: (Optional, Not Shown) A captured transom that utilizes either aluminum pressure plates in conjunction with glazing gaskets and steel screws or with structural silicone installed in accordance with the manufacturer's instructions may be installed below the curtainwall insulation (Item 2F) and may be formed of any material that complies with applicable building code and regulatory requirements. Install in accordance with the exterior curtain wall assembly manufacturer's instructions and the design specifications.



O. **ARCHITECTURAL COVER:** (Optional, Not Shown) An architectural cover that hides the perimeter joint protection (Item 3) may be installed in accordance with the exterior curtain wall assembly manufacturer's instructions and the design specifications.

P. **WINDLOAD ANCHOR:** (Optional, Not Shown) A windload anchor may be installed on the underside of the curtainwall insulation (Item 2F) and may be formed of any material that complies with applicable building code and regulatory requirements. Install in accordance with the exterior curtain wall assembly manufacturer's instructions and the design specifications.

Q. **VISION PANELS:** Vision panels are to be in compliance with exterior curtain wall assembly (Item 2) design specifications. Glazing panels may be secured in position with aluminum pressure plates in conjunction with glazing gaskets and steel screws or with structural silicone installed in accordance with the manufacturer's instructions.

3. **PERIMETER JOINT PROTECTION:** The perimeter joint (linear opening) is not to exceed 3-3/8 in. (86 mm) nominal joint width (joint width at installation) The perimeter joint treatment shall incorporate the following construction features:

A. **CERTIFIED MANUFACTURER:** Thermafiber

CERTIFIED PRODUCT: Mineral Wool

CERTIFIED MODEL: Safing

PACKING MATERIAL: Install a minimum 4 in. (102 mm) depth, as measured vertically from the top of the concrete floor assembly, of 4 pcf (64 kg/m³) density mineral wool batt insulation installed with the fibers running parallel to the slab edge and curtainwall. Divide the nominal joint width by 0.75 to provide the width of mineral wool to be cut and installed to produce the required minimum 25% compression in the nominal joint width. Install the batt insulation into the perimeter joint flush with the top surface of the concrete floor assembly (Item 1). Splices (butt joints) in the lengths of mineral wool batt insulation are to be tightly compressed together. In locations around every mounting attachment (Item 2A) that exists within the perimeter joint protection, increase the depth of mineral wool to a minimum 6 in. (152 mm). This increased depth is to be applied for a minimum horizontal distance of 2 in. (51 mm) on both sides of the mounting attachment. For any exposed surface of the mounting attachment flush with the top of the joint, install a minimum 3/4 in. (19 mm) layer of packing material over the mounting attachment for the width of the joint. The cover requires no attachment and is to extend a minimum of 2 in. (51 mm) on each side of the exposed mounting attachment. No cover is required for mounting attachment elements that fully extend above the surface of the packing material.



B. CERTIFIED MANUFACTURER: Specified Technologies, Inc.

CERTIFIED PRODUCT: Joint Sealant Spray

CERTIFIED MODEL: SpecSeal® AS200 Series Elastomeric Firestop Spray, or SpecSeal® Fast Tack® Firestop Spray

FILL VOID OR CAVITY MATERIAL: Apply a minimum wet film thickness of 1/8 in. (3.2 mm) over the packing material (Item 3A)

and overlap the liquid spray material a minimum 1/2 in. (12.7 mm) onto the interior surface of the adjacent curtain wall assembly (Item 2) and the concrete floor assembly (Item 1). If the spraying process is stopped and the applied liquid spray material cures to an elastomeric film before the process is restarted, then overlap the edge of the cured spray material at least 1/8 in. (3 mm) with the liquid spray material.

Consult the listing report on the Directory of Building Products (<https://bpdirectory.intertek.com>) for the edition of the standard(s) evaluated.

Compliance of the assembly described in this Design Listing with the referenced standard relies on verification that the assembly constructed in the field is consistent with that described herein. Intertek certified products may be verified by the approved Intertek label; other products must be verified by the Authority Having Jurisdiction as meeting the specifications stated herein.