Specified Technologies, Inc.
Design No. STI/BPF 120-39
Perimeter Fire Barrier System – Curtain Wall Assembly
SpecSeal® AS200 Series Elastomeric Spray or
SpecSeal® FastTack® Firestop Spray
ASTM E2307, CAN/ULC-S115
Rating: F-Rating – 2 Hour
UL 2079 L-Rating < 2 SCFM/LF
ASTM E1399
Movement Type = Class IV
Rated for ± 5% Vertical Movement @ 33% Compression (Item 4A)

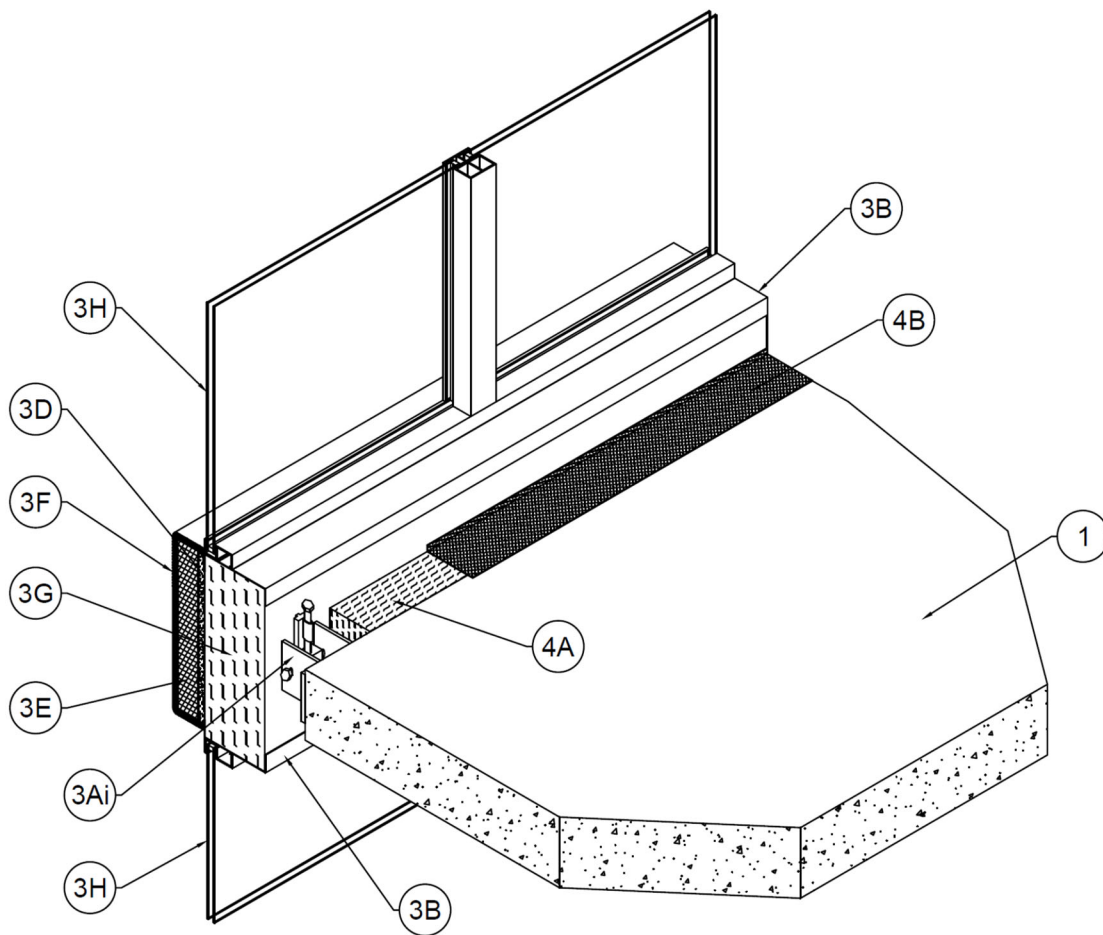

Figure 1 - Isometric with Interior Vertical Mullion Detail

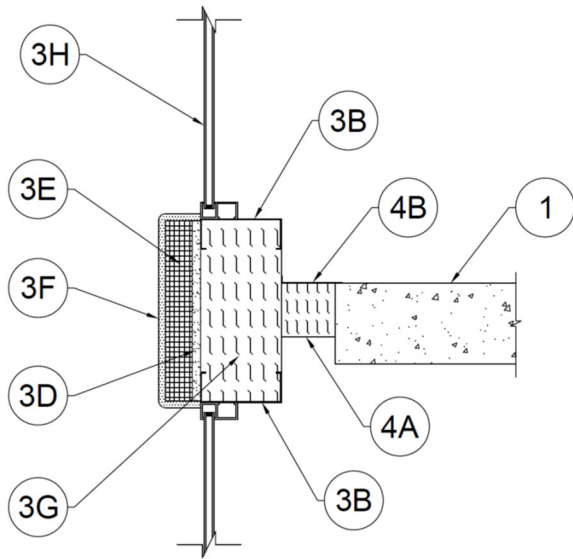

Figure 2 - Base Detail Between Anchors

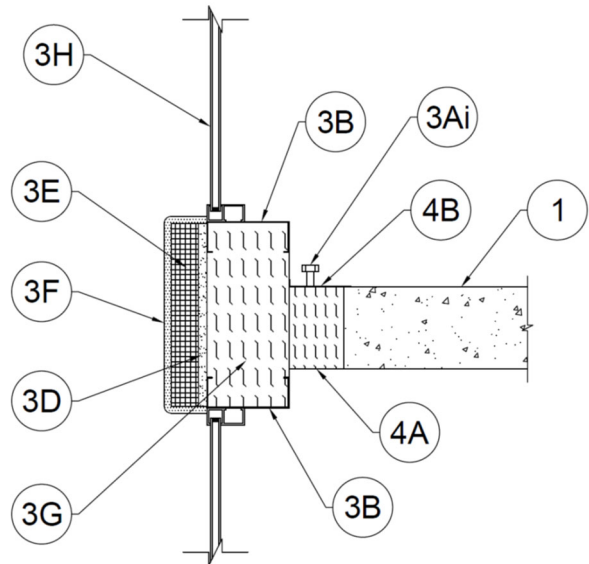

Figure 3 - Base Detail at Anchors

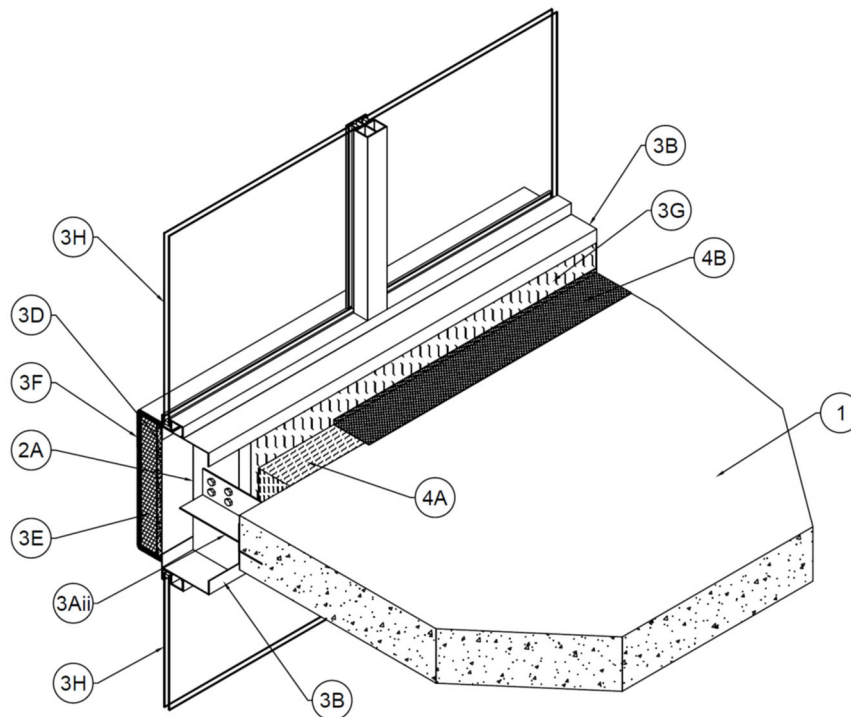

Figure 4 - Isometric with Mounting Angle Attachment

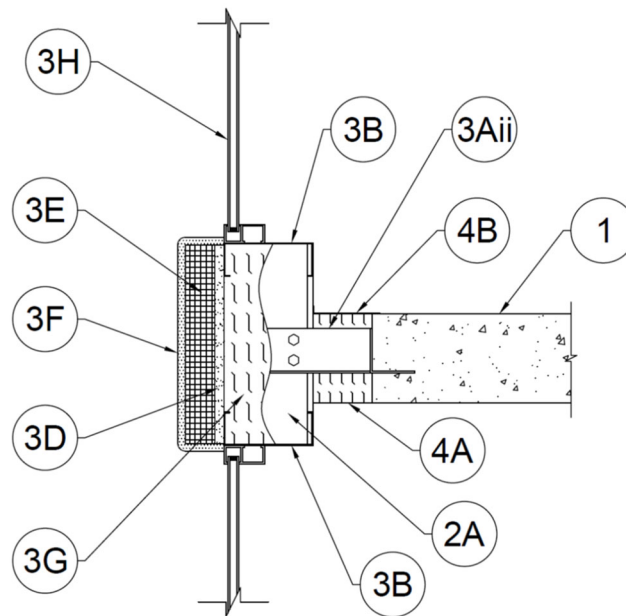

Figure 5 - Base Detail With Steel Angle Anchor

1. **CONCRETE FLOOR ASSEMBLY:** Min. one hour rated concrete floor assembly made from either lightweight or normal weight concrete with a density of 100-150 pcf, with a min. thickness of 6 in. (152 mm) at the joint face. F-rating of perimeter joint system will be limited to the fire rating of the floor system with a max. two hour F rating.
 - A. **INTERIOR STEEL STUD FRAMING** – Min. 24 GA, 3-1/2 in. (89 mm) or larger steel studs and track. Track is to be secured directly to the underside of the concrete floor assembly (Item 1). Framing spacing dimensions are to be max. 24 in. (610 mm) on center (oc). As an option, a framed knee wall may also be constructed above the concrete floor assembly.
 - B. **INTERIOR GYPSUM WALLBOARD** – Min. 1/2 in. (13 mm) interior gypsum wallboard mounted to the interior side of the interior steel stud framing (Item 2A). Secure with self-tapping drywall screws with spacing as directed by gypsum wallboard manufacturer.
2. **INTERIOR WALL ASSEMBLY:** (Optional, Not Shown) The interior wall assembly shall incorporate the following construction features:
 - A. **INTERIOR STEEL STUD FRAMING** – Min. 24 GA, 3-1/2 in. (89 mm) or larger steel studs and track. Track is to be secured directly to the underside of the concrete floor assembly (Item 1). Framing spacing dimensions are to be max. 24 in. (610 mm) on center (oc). As an option, a framed knee
3. **CURTAIN WALL ASSEMBLY:** Construct the exterior wall assembly in compliance with applicable Building Code and regulatory requirements. Spandrel panel shall extend a min. of 11/16 in. (17 mm) below the concrete floor assembly (Item 1) and shall terminate into vision glass (Item 3H), a min. of 1-13/16 in. (46 mm) above the concrete floor assembly.



- A. MOUNTING ATTACHMENT – The following mounting attachment methods may be used:
- i. FACE-MOUNTED ANCHOR – Anchor shall consist of 10-1/2 in. wide (267 mm) wide × 5-1/2 in. (140 mm) high × 3/8 in. (9.5 mm) thick aluminum brackets connecting to an extruded aluminum fist and sliding block, using steel bolts and set screws. Aluminum fist is anchored to the exterior wall framing (Item 3B). Bracket is secured to the front face of the floor (Item 1) using embedded steel anchors or nominal 5/8 in. (16 mm) diameter wedge anchors and steel washers and nuts. Joint assembly and mounting to be installed to allow for specified vertical movement and no horizontal movement.
 - ii. MOUNTING ANGLES – Nominal 3 in. (76 mm) long angles with one nominal 3 in. (76 mm) leg for attachment to edge of floor assembly and with one leg approximately 2-1/2 in. to 3 in. (64 mm to 76 mm) longer than distance to interior face of steel studs. Angles to be formed of min. 1/8-in. (3.2 mm) thick steel. Angles to be mounted to the floor with steel concrete anchors or welded to cast-in-place structural steel angle at edge of floor assembly (Item 1) on one side of each steel stud (Item 2B) at each floor level. Top edge of each mounting angle to be recessed 1/2 in. to 1 in. (13 mm to 25 mm) below top surface of floor.
- B. EXTERIOR STEEL STUD FRAMING – Use min. 16 GA, 3-5/8 in. (89 mm) or larger steel studs and track. Anchor the steel stud framing to the concrete structure or structural framing in accordance with the curtain wall assembly (Item 3) manufacturer’s instructions and the structural design specifications.
- C. KING STUDS – (Not Shown) Where king studs are used to support window framing on the vertical sides, use either two 16 GA steel studs tack welded face-to-face, or a single 16 GA steel stud as per the wall system design requirements. When two 16 GA steel studs are welded face-to-face, the core stud cavity between the studs may be, but is not required to be, filled with insulation.
- D. EXTERIOR GRADE CORE BOARD – Use min. 1/2 in. (13 mm) exterior grade gypsum wallboard or fiber-reinforced cement board mounted to the exterior side of the exterior steel stud framing (Item 3B). Secure with self-tapping drywall screws at max. 12 in. (305 mm) oc. If required, install on the exterior of the core board, an air/vapor barrier that complies with applicable Building Code and regulatory requirements.
- E. EXTERIOR INSULATION – Use min. 2 in. (51 mm) thick, nominal 8 pcf (128 kg/m³) density exterior grade mineral wool, installed in accordance with the exterior curtain wall assembly (Item 3) design specifications.
- F. EXTERIOR CLADDING – Install a Building Code compliant exterior-grade stucco system over the exterior insulation (Item 3E) in accordance with the stucco manufacturer’s installation instructions.



G. **CERTIFIED PRODUCT:** Thermafiber Safing

INTERIOR INSULATION – Use min. 3-1/2 in. (89 mm) thick, faced or unfaced, min. 4 pcf (64 kg/m³) mineral wool curtain wall insulation placed in the stud cavities.

H. VISION PANELS – (Optional) Vision panels must comply with exterior curtain wall assembly (Item 3) design specifications. Glazing panels may be secured in position with aluminum pressure plates in conjunction with glazing gaskets and steel screws or with structural silicone installed in accordance with the manufacturer's instructions.

I. EXTERIOR GRADE SEALANT – (Optional, Not Shown) At the seams between panels, exterior grade silicone sealant may be installed for weatherproofing as needed per the wall assembly design specifications.

4. **PERIMETER JOINT PROTECTION:** The perimeter joint (linear opening) is not to exceed 5 in. (102 mm) nominal joint width (joint width at installation). The perimeter joint treatment shall incorporate the following construction features:

A. **CERTIFIED PRODUCT:** Thermafiber Safing

PACKING MATERIAL – Install min. 4 in. thick (102 mm) 4 pcf (64 kg/m³) density mineral wool batt insulation installed with the fibers running parallel to the slab edge and

curtainwall. Cut and stack additional batt sections as needed so that the total thickness is min. 33% greater than the linear opening. Compress the packing material 33% in the nominal joint width. Install the batt insulation into the perimeter joint flush with the top surface of the concrete floor slab (Item 1). Splices (butt joints) in the lengths of mineral wool batt insulation are to be tightly compressed together. At mounting bracket locations, maintain continuous insulation beneath brackets by increasing insulation to a min. 6 in. (152 mm) depth for a min. of 3 in. (76 mm) on each side of the bracket, and having a min. 1 in. (25 mm) depth below the bracket.

B. **CERTIFIED PRODUCT:** Specified Technologies, Inc. SpecSeal® AS200 Elastomeric Firestop Spray (AS205 Series), or SpecSeal® FastTack® Firestop Spray

FILL VOID OR CAVITY MATERIAL – Apply a min. wet film thickness of 1/8 in. (3.2 mm) over the packing material (Item 4A) and overlap the liquid spray material a min. 1/2 in. (13 mm) onto the interior surface of the adjacent curtain wall assembly (Item 3) and the concrete floor slab assembly (Item 1). If the spraying process is stopped and the applied liquid spray material cures to an elastomeric film before process is restarted, then overlap the edge of the cured spray material at least 1/8 in. (3.2 mm) with the liquid spray material.



Consult the listing report on the Directory of Building Products (<https://bpdirectory.intertek.com>) for the edition of the standard(s) evaluated.

Compliance of the assembly described in this Design Listing with the referenced standard relies on verification that the assembly constructed in the field is consistent with that described herein. Intertek certified products may be verified by the approved Intertek label; other products must be verified by the Authority Having Jurisdiction as meeting the specifications stated herein.