Specified Technologies, Inc.
Design No. STI/BPF 120-41
Perimeter Fire Barrier System – Curtain Wall Assembly
SpecSeal® AS200 Series Elastomeric Spray
SpecSeal® FastTack® Firestop Spray
ASTM E2307, CAN/ULC-S115
Rating: F-Rating – 2 hr.
UL 2079 L-Rating < 2 SCFM/LF
Movement Type = Class IV
Rated for ± 5% Vertical Movement @ 25% Compression (Item 3A)

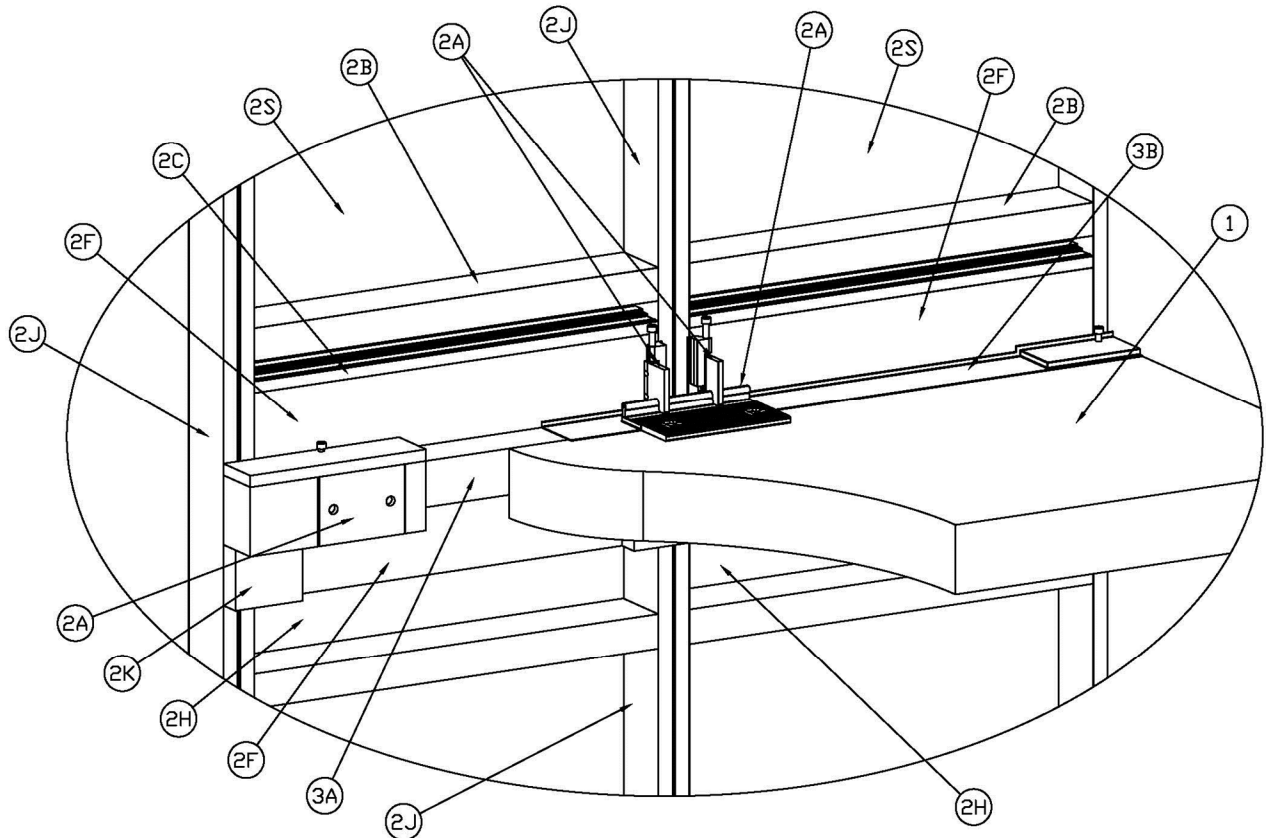

Figure 1 - Isometric with Interior Vertical Mullion Detail

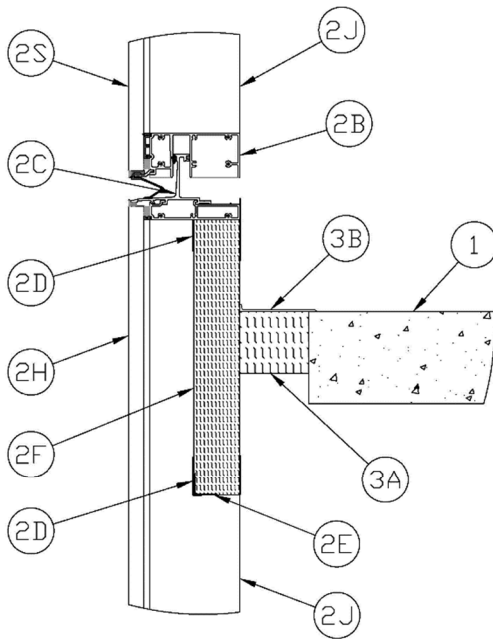

Figure 2 - Base Detail Between Anchors

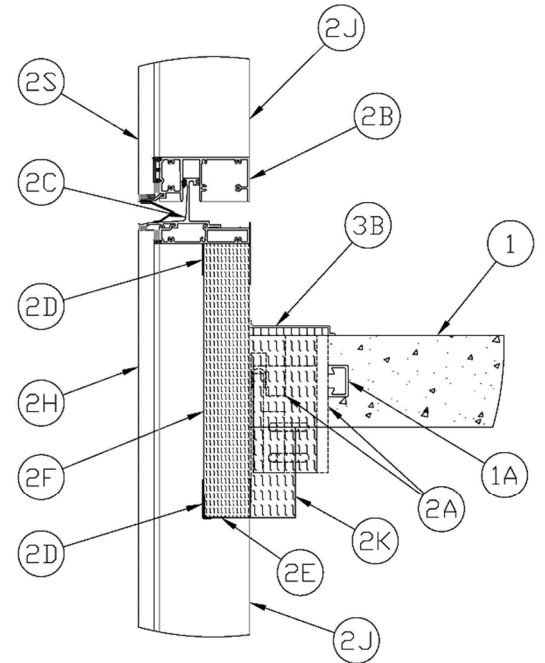

Figure 3 - Base Detail at Anchor (Face of Slab)

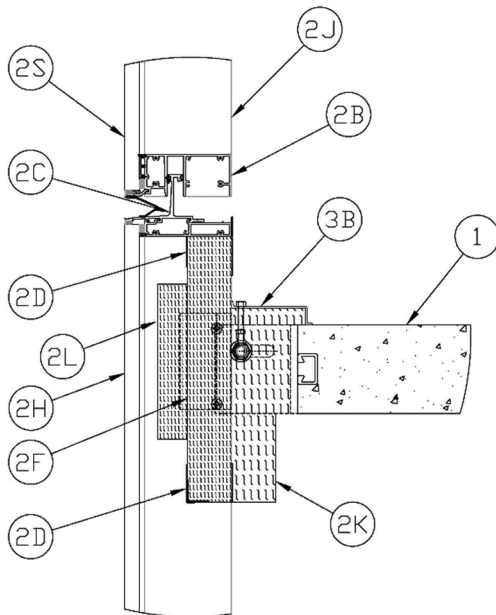

Figure 4 - Base Detail at Anchor (Jamb)

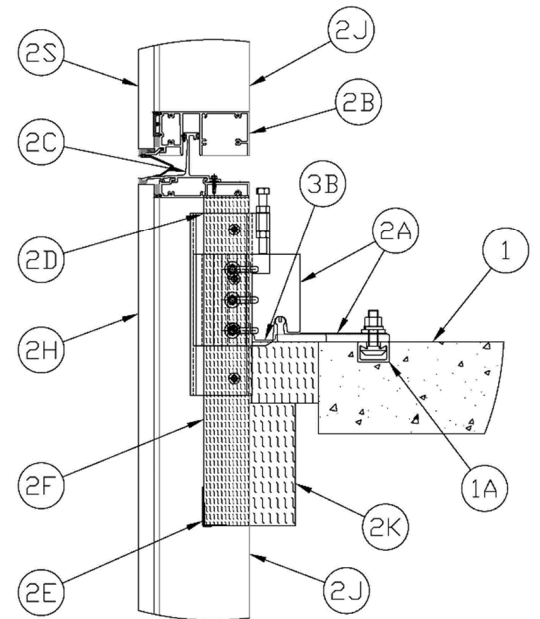

Figure 5 - Base Detail at Anchor (Top of Slab)

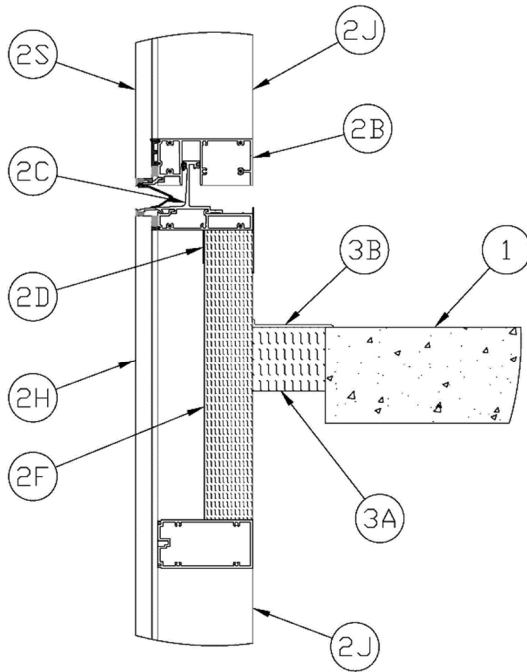

Figure 6 - Kiss Transom Configuration

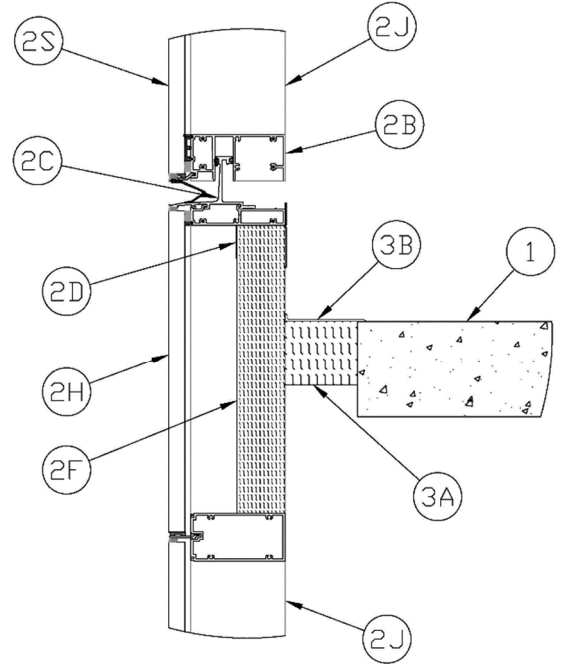

Figure 7 - Captured Transom Configuration

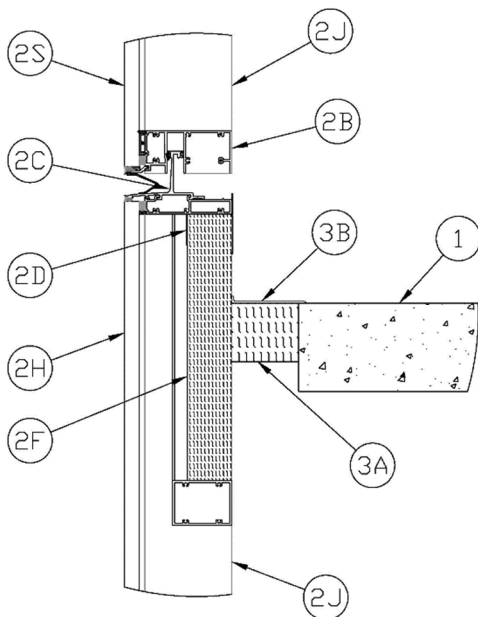

Figure 8 - Intermediate Transom with shadowbox Configuration

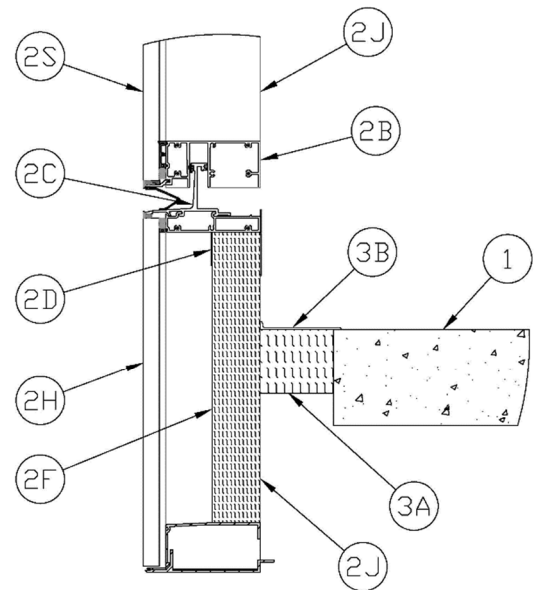

Figure 9 - Windload Anchor Configuration

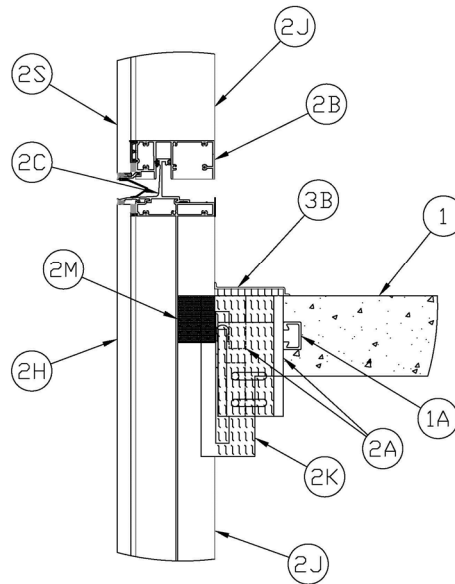

Figure 10 - Base Detail Between Face-Mounted Anchor (Mullion Plug)

1. **CONCRETE FLOOR ASSEMBLY:** Min. one-hour rated concrete floor assembly made from either lightweight or normal weight concrete with a density of 100-150 pcf, with a min. thickness of 6 in. (152 mm) at the joint face. F rating will be determined by the rating of the concrete floor assembly system up to a max. 2-hr F-rating.
 - A. **STEEL EMBED:** For the mounting attachment (Item 2A) min. 1-3/8 in. x 2 in. (35 mm x 51 mm) steel tube embeds with 7/8 in. (22 mm) slots on the front face are to be positioned at each mullion to accommodate the specific mounting attachment (Item 2A) in accordance with the curtain wall assembly (Item 2) manufacturer's instructions. Embeds may be cast in place flush with the edge of the concrete floor assembly for jamb anchors (Item 2Aii), or with the top surface of the concrete floor assembly for top-of-slab anchors (Item 2Ai) in accordance with the anchor manufacturer's installation instructions.
2. **CURTAIN WALL ASSEMBLY:** Construct the exterior wall assembly in compliance with applicable building codes and regulatory requirements. The core of the spandrel, comprised of all components noted in Items 2B through 2H below, spans from a min. 5-1/2 in. (140 mm) above the concrete floor assembly to a min. 6-1/2 in. (165 mm) below the concrete floor assembly. Other elements that exist within the spandrel and are marked optional are complimentary to the design and shall be installed per the



curtain wall manufacturer's design specifications.

A. **MOUNTING ATTACHMENT:** The mounting attachment may consist of one or more of the following types:

- i. **FACE OF SLAB ANCHOR:** The face-mounted attachment consists of twin, L-shaped brackets installed back-to-back, with the 1/2-in. (13 mm) extruded aluminum mounting face secured to the embed slot with T bolt fasteners. The blade of the anchor, perpendicular to the slab edge, is formed of 3/8-in. (9.5 mm) thick aluminum and extends into a 2-1/8 in. (54 mm) wide × 11-3/4 in. (298 mm) tall slot in the interior face of the mullion. The blade accommodates connecting hardware that supports a hooked plate that is attached to the interior of the mullion and exits through the mullion slot. When this anchor is used, an intumescent foam mullion plug (Item 2M) is installed so the top of the foam plug is flush with the top of the mullion slot with the intumescent pad positioned on the bottom of the mullion plug.
- ii. **TOP-OF-SLAB ANCHOR:** The top-of-slab anchor utilizes a 1/2-in. (13 mm) aluminum extruded plate measuring nominally 12 in. (305 mm) in width and 7.5 in. (191 mm) in length that spans across the top side of the perimeter joint protection (Item 3). The mullions are fitted with a hooked plate that mounts to the exterior side face of the mullion on both sides, using

connecting hardware in accordance with the anchor manufacturer's instructions.

- iii. **JAMB ANCHOR:** The jamb anchor, used primarily at building corners and terminations, is formed using twin, U-shaped, extruded aluminum shapes 1/2-in. (13 mm) in thickness. These are inverted, facing each other within the safing slot with one plate mounted to the face-of-slab embeds using T-bolts, and the other mounted to one side of the mullion. The face-mounted plate accommodates a "monkey bar" between the U-Shaped bracket, and a hooked plate is mounted to the exterior side U-shaped bracket which engages with the monkey bar to support the wall system. The jamb anchor face-mounted U-shaped bracket is 6 in. (152 mm) tall and may be mounted at any vertical position on the concrete floor assembly edge, flush with the top or bottom of the concrete floor assembly, or anywhere vertically in between. The exterior U-shaped bracket is 6.5 in. (165 mm) tall and the underside of the anchor may be positioned up to 1/4 in. (6 mm) or anywhere above that position. When the jamb anchor is used, and the exterior U-shaped bracket extends beyond the outer surface of the curtainwall insulation (Item 2F), the bracket face must be covered with the exterior jamb anchor protection (Item 2L).



B. **UPPER TRANSOM:** The sill of the upper transom is positioned a min. of 11-1/8 in. (283 mm) above the top of the concrete floor assembly and the underside of the stack is positioned a min. 5-1/2 in. (140 mm) above the top of the concrete floor assembly. The upper transom consists of nominal 1/8 in. (3 mm) extruded aluminum with an exterior wet chamber and interior geometry that receives the “chicken head” from the anchor head extrusion (Item 2C), forming the stack joint. The front-to-back width of the upper transom is min. 5-7/8 in. (149 mm).

C. **ANCHOR HEAD:** The anchor head consists of nominal 1/8 in. (3 mm) thick extruded aluminum having a complex shape and a nominal 1-11/16 in. (43 mm) × 2-1/8 in. (48 mm) slot on the interior side of the transom. The height of the anchor head extrusion, from the bottom to the top of the “chicken head,” is nominally 4-1/4 in. (108 mm) and the width from front to back is 5-7/8 in. (149 mm). The anchor head contains a wet chamber on the exterior side and on the interior may be constructed with a single or double “chicken head” per the design of the manufacturer. The upper transom (Item 2B) and the anchor head engage at the stack joint and the bottom of the anchor head extrusion is positioned a min. 5-1/2 in. (140 mm) above the top of the concrete floor assembly surface.

D. **CURTAINWALL INSULATION RETAINING SYSTEM:** A steel retaining clip system is used to secure the curtainwall insulation (Item 2F) to the

spandrel. The clip system may consist of any combination of the following styles:

- i. **U-SHAPED STEEL BRACKET:** When Specified Technologies, Inc. SpecSeal® QuickClip™ U-shaped brackets are used, a min. of two brackets, made from 20 GA steel, are required for each mullion in the spandrel, one above and one below the concrete floor assembly (Item 1). U-shaped brackets serve to support curtainwall insulation (Item 2F) in spandrels on both sides of the mullion simultaneously. U-shaped brackets can be used in tandem with another U-shaped bracket or Z-shaped brackets (Item 2Dii) above or below the concrete floor assembly interchangeably. U-shaped brackets are secured to the interior face of mullions (Item 2J) and are used to secure spandrel insulation within framed openings by means of a staple-shaped fastener that penetrates the insulation and interlocks with the bracket. A single 1/2 in. (12.7 mm) No. 10 self-tapping screw is required to secure the bracket on the interior side of the mullion. The bottom of the brackets, below the concrete floor assembly, are to be located a max of 6-1/2 in. (165 mm) under the concrete floor assembly. When U-shaped brackets are used above the



concrete floor assembly, they are to be located on the mullion a max 2 in. (51 mm) below the transom. U-shaped brackets cannot be used on the transom. Brackets below the concrete floor assembly are to engage with and support steel stiffener angles (Item 2E), to support the bottom edge of the curtainwall insulation (Item 2F). Brackets are to be installed onto mullions per the manufacturer's instructions.

- ii. **Z-SHAPED STEEL BRACKET:** When Specified Technologies, Inc. SpecSeal® QuickClip™ Z-shaped brackets are used, a min. of four brackets, made from 20 GA steel, are required for each mullion in the spandrel, two above and two below the concrete floor assembly (Item 1). Z-shaped brackets can be used in tandem with other Z-shaped brackets or a single U-shaped bracket (Item 2Di) above or below the concrete floor assembly interchangeably. Z-shaped brackets may be secured to the internal side, or cavity side of the mullion (Item 2J) and/or underside of the anchor head transom (Item 2C) and are used to secure spandrel insulation within framed openings by means of a staple-shaped fastener that penetrates the insulation and interlocks with the

bracket. A single 1/2 in. (12.7 mm) No. 10 self-tapping screw is required to secure the bracket on the interior side of the mullion, the side face of the mullion, or the underside of the transom. The bottom of the brackets, below the concrete floor assembly, are to be located a max of 6-1/2 in. (165 mm) below the concrete floor assembly. When Z-shaped brackets are used above the concrete floor assembly, they are to be located on the mullion a max. of 2 in. (51 mm) below the transom, or if placed on the transom a max. 6 in. (152 mm) from the mullion. Brackets below the concrete floor assembly are to engage with and support the steel stiffener angles (Item 2E), to support the bottom edge of the curtainwall insulation (Item 2F). Brackets are to be installed onto mullions or transoms per the manufacturer's installation instructions.

- iii. **L-SHAPED STEEL BRACKET:** When Specified Technologies, Inc. SpecSeal® QuickClip™ L-shaped brackets are used, a min. of four brackets, made from 20GA steel, are required for each mullion in the spandrel, two above and two below the concrete floor assembly (Item 1). When installed above the floor,



L-shaped brackets may be used in tandem with Z-shaped (Item 2Dii) or U-Shaped brackets (Item 2Di). When installed below the floor as support for steel stiffeners in the same spandrel cavity, they may only be used with other L-shaped brackets. L-shaped brackets are installed onto the side face of mullions (Item 2J) or underside of the anchor head transom (Item 2C) to secure spandrel insulation within framed openings by means of a staple-shaped fastener that penetrates the insulation and interlocks with the bracket. A single 1/2 in. (12.7 mm) No. 10 self-tapping screw is required to secure the bracket on the side face of the mullion or underside of the transom. The bottom of brackets, below the concrete floor assembly, are to be located a max of 6-1/2 in. (165 mm) below the concrete floor assembly. When L-shaped brackets are used above the concrete floor assembly, they are to be located on the mullion a max of 2 in. (51 mm) below the transom, or if placed on the transom a max. 6 in. (152 mm) from the mullion. Brackets below the concrete floor assembly are to engage with and support the steel stiffener angles (Item 2E), to support the bottom edge of the curtainwall insulation (Item 2F).

When L-shaped brackets are used, additional L-shaped brackets are to be secured with a single 1/2 in. (12.7 mm) No. 10 self-tapping screw to the steel stiffener (Item 2E) at a max. spacing of 20 in. (508 mm) on center (oc) with the back of the L-shaped bracket on the opposite side of the vertical flange of the stiffener angle to provide additional back-bracing for the curtainwall insulation (Item 2F) on the exterior side of the curtainwall insulation. As an option to the L-shaped bracket being secured to the stiffener angle, cup-head or impaling pin, min. 12 GA, min. 2-3/16 in., steel weld pins with speed washers may be welded to the horizontal centerline of the steel stiffener angle (Item 2E) at a max. spacing of 20 in. (508 mm) to secure the support the curtainwall insulation (Item 2F). Brackets are to be installed onto mullions or transoms per the manufacturer's installation instructions.

- E. STEEL STIFFENER ANGLES:** Install min. 20 GA 1-1/2 in. × 1-1/2 in. (38 mm × 38 mm) steel angles to support the underside of the curtainwall insulation (Item 2F). The steel angle is to engage with the curtainwall insulation retention system (Item 2D) per the manufacturer's installation instructions. When U-shaped (Item 2Di)



or Z-shaped (Item 2Dii) brackets are used, the vertical leg of the stiffener angle is on the exterior side of the curtainwall insulation (Item 2F). When L-shaped (Item 2Diii) angles are used the vertical leg of the stiffener angle is on the interior side of the curtainwall insulation.

F. CERTIFIED PRODUCT: Thermafiber Firespan 90

CURTAINWALL INSULATION: Install min. 3 in. (76 mm) thick 8 pcf (128 kg/m³) density mineral wool with foil-scrim facing on the interior side into the spandrel, flush with the interior side of the mullions. Insulation batt is to be butted up to the underside of the anchor head transom and friction fit between the mullions with a min. 1/8 in. (3 mm) over-cut on the spandrel width. The insulation is to extend from the underside of the anchor head transom downward in the spandrel cavity a min. 18 in. (457 mm). The curtainwall insulation is to be secured with the Curtainwall Insulation Retention System (Item 2D). The curtainwall insulation is not required to terminate at a lower transom. Space below the curtainwall insulation between the bottom of the insulation and the next lower transom may be left void or filled with alternative insulative materials (Item 2G).

G. ALTERNATIVE INSULATIVE MATERIALS:

(Optional, Not shown) In any space that exists below the curtainwall insulation (Item 2F), where insulation is required for energy conservation requirements or other purposes, the space may be filled with any material that complies with applicable building code and regulatory requirements.

H. EXTERIOR SPANDREL CLADDING:

(Optional) Install glazing or an exterior cladding system that complies with applicable building code and regulatory requirements. Install in accordance with the exterior curtain wall assembly manufacturer's instructions and the design specifications. Glazing panels or other specified cladding may be secured in position with aluminum pressure plates in conjunction with glazing gaskets and steel screws or with structural silicone installed in accordance with the manufacturer's instructions.

I. SHADOW BOX: (Optional, Not shown) –

A shadow box installed on the exterior side of the curtainwall insulation (Item 2F) may be formed of any material that complies with applicable building code and regulatory requirements. Install in accordance with the exterior curtain wall assembly manufacturer's instructions and the design specifications.

J. VERTICAL MULLIONS: Vertical mullions

are constructed of nominal 1/8 in. (3 mm) extruded aluminum. Mullions can be constructed as solid members, or as joining members that are split vertically.



Mullions are designed with a wet chamber on the exterior side and a dry chamber on the interior side. Mullions have a min. depth of 5-7/8 in. (149 mm) and a min. width of 3 in. (76 mm). Spacing of the mullions is min. 18 in. (457 mm) oc.

- K. **CERTIFIED PRODUCT:** Thermafiber Firespan 90

MULLION COVERS: Install min. 2 in. (51 mm) thick 8 pcf (128 kg/m³) density mineral wool with foil-scrim facing on the interior side over the vertical mullion on the interior side of the wall below the concrete floor assembly (Item 1). The mullion cover is to be centered on the mullion and extend a min. 3-1/2 in. (89 mm) on each side of the mullion and vertically extend from below the packing material (Item 3A) to the underside of the curtainwall insulation (Item 2F). Secure the mullion cover to the curtainwall insulation with steel spiral anchors that extend a min. 1 in. (25 mm) into the curtainwall insulation. Aluminum foil tape may be used to seal the mullion cover edges to the curtainwall insulation but is not required. The mullion cover may extend to the underside of the curtainwall insulation (Item 2F) but must extend a min 6-1/2 in. (165 mm) below the concrete floor assembly (Item 1).

- L. **CERTIFIED PRODUCT:** Thermafiber Firespan 90

EXTERIOR JAMB ANCHOR PROTECTION (Not shown): Where the jamb anchor U-shaped bracket extends beyond the curtainwall insulation, install min. 2 in.

(51 mm) thick 8 pcf (128 kg/m³) density mineral wool with foil-scrim facing on the interior side over the face of the U-shaped bracket so that it is protected a min. 2 in. (51 mm) on each side. Hollow out the shape of the U-shaped bracket plate face to the depth at which it extends past the curtainwall insulation (Item 2F) so the face of the insulation sits with no gap to the exterior side of the curtainwall insulation and the bracket is protected with min. 1.5 in. (38 mm) of insulation. Secure the bracket cover to the curtainwall insulation with steel spiral anchors that extend a min. 1 in. (25 mm) into the curtainwall insulation. Aluminum foil tape may be used to seal the mullion cover edges to the curtainwall insulation but is not required.

- M. **Framing Fill:** When the face-of-slab anchor (Item 2Ai) is used, insert a Specified Technologies, Inc. SpecSeal® Mullion Plug into the core of the mullion so the top of the mullion plug is flush with the top of the anchor slot in the mullion, with the intumescent pad positioned on the bottom of the mullion plug.

- N. **INTERMEDIATE TRANSOM:** (Optional, Not shown) An intermediate transom may be installed on the underside of the curtainwall insulation (Item 2F) and may be formed of any material that complies with applicable building code and regulatory requirements. Install in accordance with the exterior curtain wall assembly manufacturer's instructions and the design specifications.



O. **CONTINUOUS GLAZING FRAME (KISS TRANSOM):** (Optional, Not Shown) A continuous glazing frame (Kiss Transom) may be installed below the curtainwall insulation (Item 2F) and may be formed of any material that complies with applicable building code and regulatory requirements. Install in accordance with the exterior curtain wall assembly manufacturer's instructions and the design specifications.

P. **CAPTURED TRANSOM:** (Optional, Not shown) A captured transom that utilizes either aluminum pressure plates in conjunction with glazing gaskets and steel screws or with structural silicone installed in accordance with the manufacturer's instructions may be installed below the curtainwall insulation (Item 2F) and may be formed of any material that complies with applicable building code and regulatory requirements. Install in accordance with the exterior curtain wall assembly manufacturer's instructions and the design specifications.

Q. **ARCHITECTURAL COVER:** (Optional, Not Shown) An architectural cover that hides the perimeter joint protection (Item 3) may be installed in accordance with the exterior curtain wall assembly manufacturer's instructions and the design specifications.

R. **WINDLOAD ANCHOR:** (Optional, Not shown) A windload anchor may be installed on the underside of the curtainwall insulation (Item 2F) and may be formed of any material that complies

with applicable building code and regulatory requirements. Install in accordance with the exterior curtain wall assembly manufacturer's instructions and the design specifications.

S. **VISION PANELS:** Vision panels are to be in compliance with exterior curtain wall assembly (Item 2) design specifications. Glazing panels may be secured in position with aluminum pressure plates in conjunction with glazing gaskets and steel screws or with structural silicone installed in accordance with the manufacturer's instructions.

3. **PERIMETER JOINT PROTECTION:** The perimeter joint (linear opening) is not to exceed 4-1/2 in. (114 mm) nominal joint width (joint width at installation) The perimeter joint treatment shall incorporate the following construction features:

A. **CERTIFIED PRODUCT:** Thermafiber Safing

PACKING MATERIAL: Install a min. 4 in. (102 mm) depth, as measured vertically from the top of the concrete floor assembly, of 4 pcf (64 kg/m³) density mineral wool batt insulation installed with the fibers running parallel to the slab edge and curtainwall. Divide the nominal joint width by 0.75 to provide the width of mineral wool to be cut and installed to produce the required min. 25% compression in the nominal joint width. Install the batt insulation into the perimeter joint flush with the top surface of the concrete floor assembly (Item 1). Splices (butt joints) in the lengths of mineral wool batt insulation



are to be tightly compressed together. In locations around every mounting attachment (Item 2A) that exists within the perimeter joint protection, increase the depth of mineral wool to a min. 6 in. (152 mm). This increased depth is to be applied for a min. horizontal distance of 2 in. (51 mm) on both sides of the mounting attachment.

- B. **CERTIFIED PRODUCT:** Specified Technologies, Inc. SpecSeal® AS200 Series Elastomeric Firestop Spray, or SpecSeal® FastTack® Firestop Spray

FILL VOID OR CAVITY MATERIAL: Apply a min. wet film thickness of 1/8 in. (3.2 mm) over the packing material (Item 3A) and overlap the liquid spray material a min. 1/2 in. (12.7 mm) onto the interior surface of the adjacent curtain wall assembly (Item 2) and the concrete floor assembly (Item 1). If the spraying process is stopped and the applied liquid spray material cures to an elastomeric film before the process is restarted, then overlap the edge of the cured spray material at least 1/8 in. (3 mm) with the liquid spray material.

Consult the listing report on the Directory of Building Products (<https://bpdirectory.intertek.com>) for the edition of the standard(s) evaluated.

Compliance of the assembly described in this Design Listing with the referenced standard relies on verification that the assembly constructed in the field is consistent with that described herein. Intertek certified products may be verified by the approved Intertek label; other products must be verified by the Authority Having Jurisdiction as meeting the specifications stated herein.