Specified Technologies, Inc.
Design No. STI/BPF 120-47
Perimeter Fire Barrier System – Curtain Wall Assembly
SpecSeal® AS200 Series Elastomeric Spray
SpecSeal® FastTack® Firestop Spray
ASTM E2307, CAN/ULC-S115
Rating: F-Rating – 2 hr
Movement Type = Class IV
Rated for ± 5 % Vertical Movement @ 25% Compression (Item 3A)

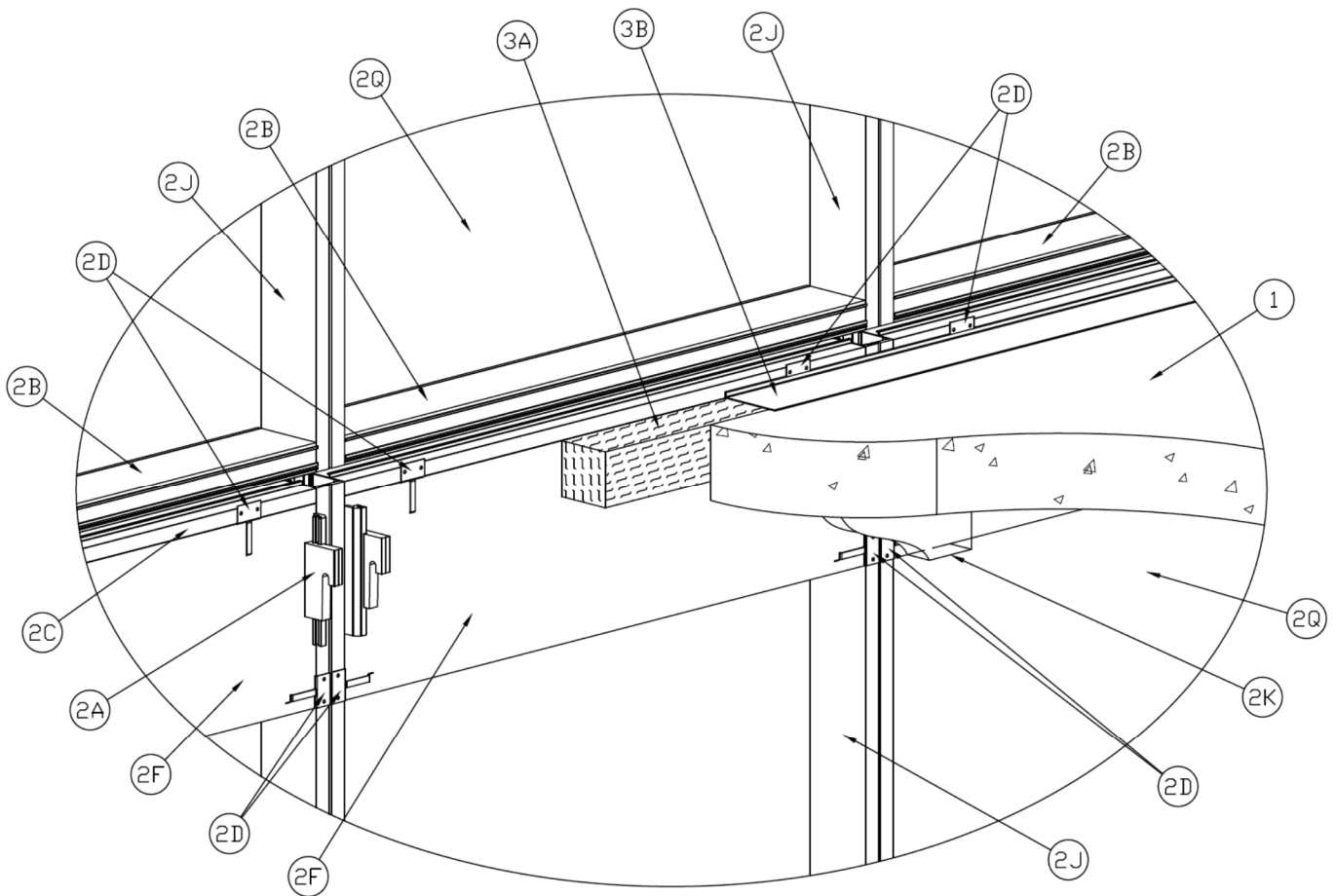

Figure 1 - Isometric with Interior Vertical Mullion Detail

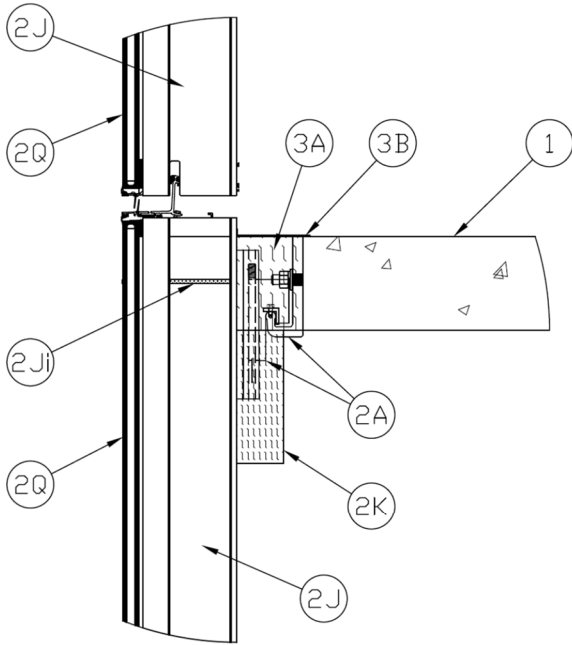

Figure 2 - Base Detail at Anchors (Face of Slab)

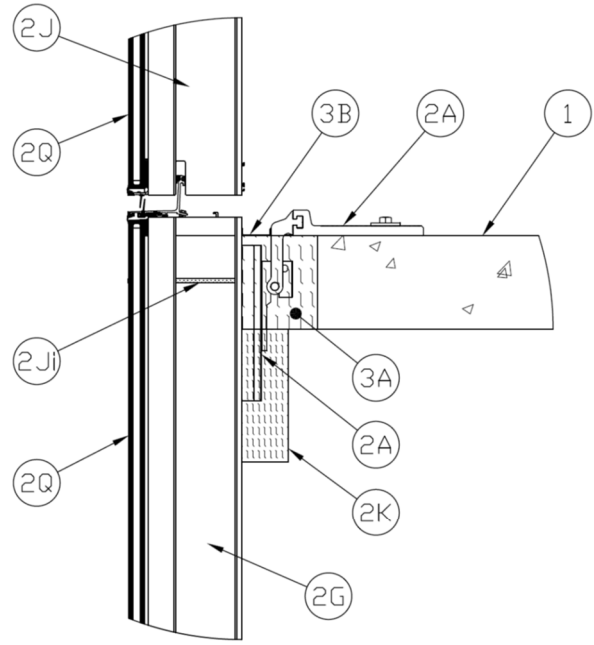

Figure 3 - Base Detail at Anchors (Top of Slab)

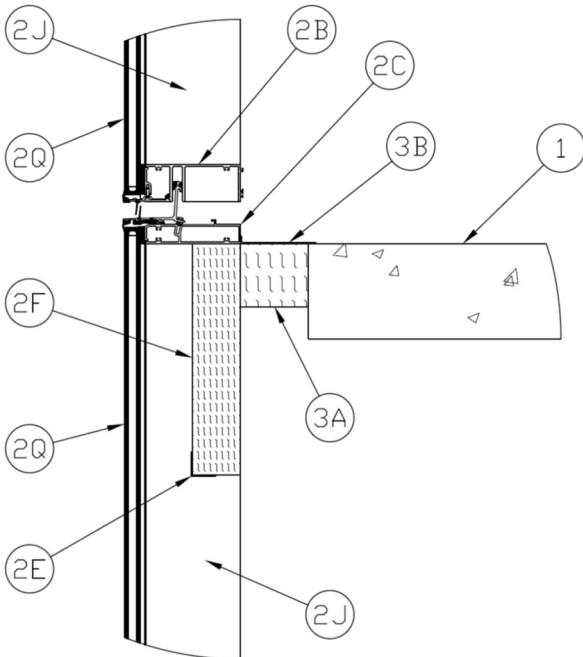

Figure 4 - Base Detail Between Anchors

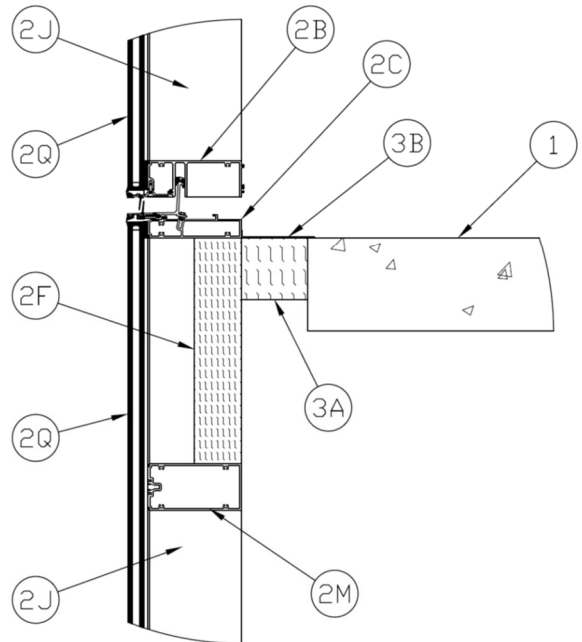

Figure 5 - Base Detail Between Anchors (Kiss Transom)

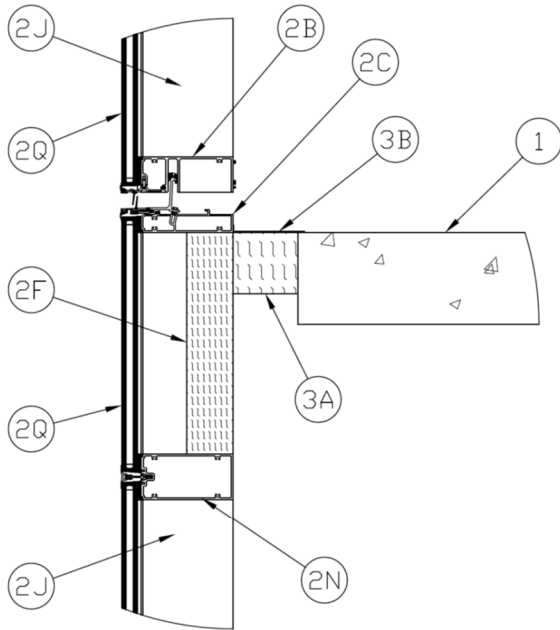

Figure 6 - Base Detail Between Anchors (Captured Transom)

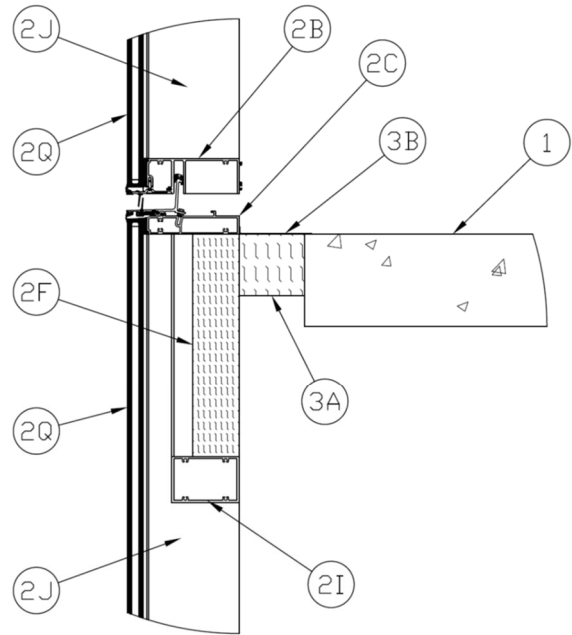

Figure 7 - Base Detail Shadow Box

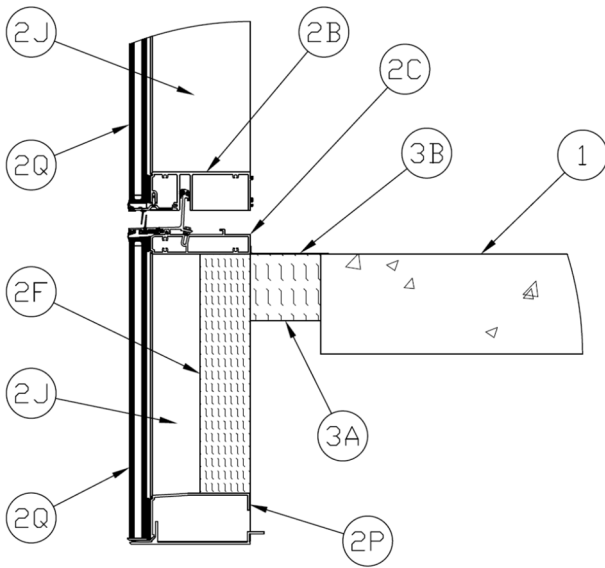

Figure 8 - Windload Anchor Configuration



1. **CONCRETE FLOOR ASSEMBLY:** Minimum one-hour rated concrete floor assembly made from either lightweight or normal weight concrete with a density of 100-150 pcf, with a minimum thickness of 6 in. (152 mm) at the joint face. F-rating will be determined by the rating of the floor system up to a maximum of two-hour F-rating.

A. **STEEL EMBED:** As required when face-mounted anchors (Item 2Ai) are used as a mounting attachment, install minimum 1-3/8 in. × 2 in. (35 mm × 51 mm) steel tube embeds with 7/8 in. (22 mm) slots on the front face are to be laterally centered at each mullion location and cast in place flush with the edge of the concrete floor assembly in accordance with the anchor manufacturer's installation instructions.

2. **CURTAIN WALL ASSEMBLY:** Construct the exterior wall assembly in compliance with applicable building codes and regulatory requirements which shall incorporate the following features:

A. **MOUNTING ATTACHMENT:** The mounting attachments to the floor slab shall consist of one or both of the following methods:

i. **FACE MOUNTED ANCHOR:** Anchor consists of a one or two-piece, 1/2 in. (13 mm) thick, extruded aluminum faceplate with minimum 3/8 in. (9.5 mm) arms that form an "L" or "J" shape that engages with an aluminum crossbar support. The height of the anchor plate is nominally 9 in. (229 mm) and may be positioned vertically at any point on the edge of the floor assembly (Item 1) from flush with the top of the concrete floor assembly and may extend up to 3 in. below the concrete

floor assembly. The mullion anchor plates are secured to the sides of the mullion, with interior edges flush with the interior face of the mullion, with steel bolts and nuts that engage with hardware internal to the mullion. The mullion anchor hook plate consists of a nominal 2-1/2 in. (64 mm) wide × 10 in. (254 mm) tall × 3/8 in. (9.5 mm) thick extruded aluminum plate with fist sliders that sit proud of the mullion face within the safig slot of the perimeter joint protection (Item 3). The fist sliders receive minimum 1/2 in. (13 mm) diameter jack bolts that are used to adjust the vertical position of the wall. The fist sliders may extend above the floor and up to 4-1/2 in. (114 mm) below the floor assembly (Item 1). The fist sliders may extend up to 4-1/2 in. (114 mm) below the packing material (Item 3A). The crossbar may extend up to 3-1/2 in. (89 mm) below the floor assembly.

ii. **TOP MOUNTED ANCHOR:** Anchor consists of a top-mounted extruded aluminum anchor plate measuring minimum 1/2 in. (13 mm) in thickness. Secure to the top of the concrete floor assembly (Item 1) in accordance with the curtain wall manufacturer's instructions with two 1/2-in. (13 mm) diameter steel masonry anchors with washer plates as supplied by the anchor manufacturer. Mounting bracket may be attached to the top of the floor or embedded within a cast anchor slot as required. Top mounted plate connects with mullion anchor plates measuring minimum 3/8 in. (10 mm) having a vertical height of minimum 10 in. (254 mm) and a width of 3 in. (76 mm)



positioned so that 2 in. (51 mm) overlap onto the mullion on both sides of the mullion. The top mounted anchor plate engages with fist sliders on the side mullion anchor plates. The fist sliders may extend from above the floor to a minimum 1 in. (25 mm) above the bottom of the packing material (Item 3A).

- B. **UPPER TRANSOM:** The sill of the upper transom is positioned nominally 5-1/2 in. (129 mm) above the top of the concrete floor assembly (Item 1) or higher. The upper transom consists of nominal 0.10 in. (2.5 mm) extruded aluminum with an exterior wet chamber and interior geometry that receives the double “chicken head” from the anchor head extrusion (Item 2C), forming the stack joint. The front-to-back width of the upper transom is minimum 6-1/8 in. (156 mm). The height of the upper transom is nominally 2-1/2 in. (64 mm).
- C. **ANCHOR HEAD:** The anchor head consists of nominal 1/8 in. (3 mm) thick extruded aluminum having a complex shape. The height of the anchor head extrusion, from the bottom to the top of the “chicken head,” is nominally 3-3/4 in. (95 mm) and the width from front to back is 6-1/8 in. (156 mm). The anchor head contains a wet chamber on the exterior side and on the interior is constructed with a double “chicken head” per the design of the manufacturer. The upper transom (Item 2B) and the anchor head engage at the stack joint and the bottom of the anchor head extrusion is positioned flush with the top of the concrete floor assembly (Item 1) surface or higher.

- i. **CERTIFIED MANUFACTURER:**
Thermafiber

CERTIFIED PRODUCT: Mineral Wool

CERTIFIED MODEL: Safing

Inside the anchor head trough between the chicken heads, install minimum 4 pcf (64 kg/m³) density mineral wool cut to a length of 6 in. (152 mm) and 3 in. (76 mm) deep. The mineral wool is to be centered over the joint between adjacent panels and extend a minimum of 3 in. (76 mm) on each side of the joint. The insulation is to be friction-fitted into place between the chicken heads and installed uncompressed to the full height of the anchor head cavity. The insulation will receive compression from the upper transom when upper panels are installed

- D. **CURTAINWALL INSULATION RETAINING SYSTEM:** A steel retaining clip system is used to secure the curtainwall insulation (Item 2F) to the spandrel. The clip system may consist of any combination of the following styles.

- i. **U-SHAPED STEEL BRACKET** (Not shown): When Specified Technologies, Inc. SpecSeal® QuickClip™ U-shaped brackets are used on the mullion, a minimum of two brackets, made from 20 GA steel, are required for each mullion in the spandrel, one above and one below the concrete floor assembly (Item 1). U-shaped brackets serve to support curtainwall insulation (Item 2F) in spandrels on both sides of the



mullion simultaneously. U-shaped brackets can be used in tandem with another U-shaped bracket or Z-shaped brackets (Item 2Dii) above or below the concrete floor assembly interchangeably. U-shaped brackets are secured to the interior face of mullions (Item 2J) and are used to secure spandrel insulation within framed openings by means of a staple-shaped fastener that penetrates the insulation and interlocks with the bracket. A single 1/2 in. (12.7 mm) No. 10 self-tapping screw is required to secure the bracket on the interior side of the mullion. The bottom of the brackets, below the floor, are to be located a maximum of 6-1/2 in. (165 mm) under the floor. When U-shaped brackets are used above the floor, they are to be located on the mullion a maximum 2 in. (51 mm) above the floor. U-shaped brackets cannot be used on the transom. Brackets below the floor are to engage with and support steel stiffener angles (Item 2E), to support the bottom edge of the curtainwall insulation (Item 2F). Brackets are to be installed onto mullions per the manufacturer's instructions.

- ii. **Z-SHAPED STEEL BRACKET** (Not Shown): When Specified Technologies, Inc. SpecSeal® QuickClip™ Z-shaped brackets are used on the mullion, a minimum of four brackets, made from 20 GA steel, are required for each mullion in the spandrel, two above and two below the concrete floor assembly (Item 1). Z-shaped brackets can be used in tandem with other Z-shaped brackets or a single U-shaped bracket (Item 2D-1) above or below the concrete floor

assembly interchangeably. Z-shaped brackets may be secured to the internal side, or cavity side of the mullion (Item 2J) and/or underside of the anchor head transom (Item 2C) and are used to secure spandrel insulation within framed openings by means of a staple-shaped fastener that penetrates the insulation and interlocks with the bracket. A single 1/2 in. (12.7 mm) No. 10 self-tapping screw is required to secure the bracket on the interior side of the mullion, the side face of the mullion, or the underside of the transom. The bottom of the brackets, below the concrete floor assembly, are to be located a maximum of 6-1/2 in. (165 mm) below the concrete floor assembly. When Z-shaped brackets are used above the concrete floor assembly, they are to be located on the mullion a maximum of 2 in. (51 mm) above the floor. When Z-shaped clips are used on the stack joint transom, they are to be spaced no more than 6 in. from the mullion, and no more than 23 in. (584 mm) oc. Install sufficient brackets to maintain the maximum allowed spacing requirement. Brackets below the concrete floor assembly are to engage with and support the steel stiffener angles (Item 2E), to support the bottom edge of the curtainwall insulation (Item 2F). Brackets are to be installed onto mullions or transoms per the manufacturer's installation instructions.

- iii. **L-SHAPED STEEL BRACKET** (Not Shown): When Specified Technologies, Inc. SpecSeal® QuickClip™ L-shaped brackets are used, a minimum of four brackets, made from 20 ga steel, are



required for each mullion in the spandrel, two above and two below the floor. L-shaped brackets are designed for factory installation and cannot be used in tandem with another Z-shaped (Item 2Dii) or U-shaped bracket (Item 2Di). L-brackets are installed onto the side face of mullions (Item 2J) or underside of the anchor head transom (Item 2C) to secure spandrel insulation within framed openings by means of a staple-shaped fastener that penetrates the insulation and interlocks with the bracket. A single 1/2 in. (12.7 mm) No. 10 self-tapping screw is required to secure the bracket on the side face of the mullion or underside of the transom. The bottom of brackets, below the floor, are to be located a maximum of 6-1/2 in. (165 mm) below the concrete floor assembly. When L-Shaped brackets are used above the floor, they are to be located on the mullion a maximum of 2 in. (51 mm) above the floor. When L-shaped clips are used on the stack joint transom, they are to be spaced no more than 6 in. from the mullion and no more than 23 in. (584 mm) oc. Install sufficient brackets to maintain the maximum allowed spacing requirement. Brackets below the concrete floor assembly are to engage with and support the steel stiffener angles (Item 2E), to support the bottom edge of the curtainwall insulation (Item 2F). When L-Brackets are used, additional L brackets are to be secured with a single 1/2 in. (12.7 mm) No. 10 self-tapping screw to the steel stiffener (Item 2E) at a max spacing of 20 in. (508 mm) on center (oc) with the back of the L bracket on the opposite side of the vertical flange of the

stiffener angle to provide additional back-bracing for the curtainwall insulation (Item 2F) on the exterior side of the curtainwall insulation. Brackets are to be installed onto mullions or transoms per the manufacturer's installation instructions

- E. **STEEL STIFFENER ANGLES:** Install minimum 16 GA 1-1/2 in. × 1-1/2 in. (38 mm × 38 mm) steel angles to support the underside of the curtainwall insulation (Item 2F). The steel angle is to engage with the curtainwall insulation retention system (Item 2D) per the manufacturer's installation instructions. When U-shaped (Item 2Di) or Z-shaped (Item 2Dii) brackets are used, the vertical leg of the stiffener angle is on the exterior side of the curtainwall insulation (Item 2F). When L-shaped (Item 2D-3) angles are used the vertical leg of the stiffener angle is on the interior side of the curtainwall insulation. If curtainwall insulation (Item 2F) is minimum 3 in. (76 mm) thick, the gauge of the steel angle may be reduced to 20 ga.
- F. **CERTIFIED MANUFACTURER:** Thermafiber

CERTIFIED PRODUCT: Mineral Wool

CERTIFIED MODEL: Firespan 90

CURTAIN WALL INSULATION: Install minimum 2 in. (51 mm) thick 8 pcf (128 kg/m³) density mineral wool with foil-scrim facing on the interior side into the spandrel, flush with the interior side of the mullions. Insulation batt is to be butted up to the underside of the anchor head transom and friction fit between the mullions with a minimum 1/8 in. (3 mm) over-cut on the spandrel width. The insulation is to extend from the underside of the anchor head



transom (Item 2C) downward in the spandrel cavity a minimum 14-3/8 in. (365 mm). The curtainwall insulation is to be secured with the Curtainwall Insulation Retention System (Item 2D). The curtainwall insulation is not required to terminate at a lower transom. Space below the curtainwall insulation between the bottom of the insulation and the next lower transom may be left void or filled with alternative insulative materials (Item 2G).

- G. **ALTERNATIVE INSULATIVE MATERIALS:** In any space that exists below the curtainwall insulation (Item 2F), where insulation is required for energy conservation requirements or other purposes, the space may be filled with any material that complies with applicable building code and regulatory requirements.
- H. **EXTERIOR SPANDREL CLADDING:** (Optional) Install glazing or an exterior cladding system that complies with applicable building code and regulatory requirements. Install in accordance with the exterior curtain wall assembly manufacturer's instructions and the design specifications. Glazing panels or other specified cladding may be secured in position with aluminum pressure plates in conjunction with glazing gaskets and steel screws or with structural silicone installed in accordance with the manufacturer's instructions.
- I. **SHADOW BOX:** (Optional) – A shadow box installed on the exterior side of the curtainwall insulation (Item 2F) may be formed of any material that complies with applicable building code and regulatory requirements. Install in accordance with the exterior curtain wall assembly

manufacturer's instructions and the design specifications.

- J. **VERTICAL MULLIONS:** Vertical mullions are constructed of nominal 1/8 in. (3 mm) extruded aluminum. Mullions can be constructed as solid members, or as joining members that are split vertically. Mullions are designed with a wet chamber on the exterior side and a dry chamber on the interior side. Mullions have a minimum depth of 7 in. (178 mm) and a minimum width of 3 in. (76 mm). Spacing of the mullions is minimum 40-1/2 in. (103 cm) oc.
- i. **MULLION PLUG:** When a true stack joint is present, a Specified Technologies, Inc. mullion plug must be applied within the dry cavity of the mullion, with the top edge of the mullion foam flush with the top of the floor and with the intumescent side of the plug facing downward. Plug shall be cut to match the profile of the mullion cavity it is placed in and sized slightly larger than the cavity as to fully fill the space and form a friction fit.
- ii. **CERTIFIED MANUFACTURER:**
Thermafiber
- CERTIFIED PRODUCT:** Mineral Wool
- CERTIFIED MODEL:** Safing
- MULLION FILLER:** Any dry cavity space that exists above the mullion plug (Item 2Ji), up to the bottom of the true stack joint, must be filled with 4 pcf (64 kg/m³) density mineral wool, loosely packed into the cavity space.



K. **CERTIFIED MANUFACTURER:** Thermafiber

CERTIFIED PRODUCT: Mineral Wool

CERTIFIED MODEL: Firespan 90

MULLION COVERS: Install minimum 2 in. (51 mm) thick 8 pcf (128 kg/m³) density mineral wool with foil-scrim facing on the interior side over the vertical mullion on the interior side of the wall below the concrete floor assembly (Item 1). The mullion cover is to be centered on the mullion and extend a minimum 3-1/2 in. (89 mm) on each side of the mullion and vertically extend from below the packing material (Item 3A) to minimum 5-3/4 in. (146 mm) below the concrete floor assembly. Secure the mullion cover to the curtainwall insulation with steel spiral anchors that extend a minimum 1 in. (25 mm) into the curtainwall insulation. Aluminum foil tape may be used to seal the mullion cover edges to the curtainwall insulation but is not required.

L. **INTERMEDIATE TRANSOM:** (Optional) An intermediate transom may be installed on the underside of the curtainwall insulation (Item 2F) and may be formed of any material that complies with applicable building code and regulatory requirements. Install in accordance with the exterior curtain wall assembly manufacturer's instructions and the design specifications.

M. **CONTINUOUS GLAZING FRAME (KISS TRANSOM):** (Optional) A continuous glazing frame (Kiss Transom) may be installed below the curtainwall insulation (Item 2F) and may be formed of any material that complies with applicable building code and regulatory requirements. Install in accordance with the exterior curtain wall

assembly manufacturer's instructions and the design specifications.

N. **CAPTURED TRANSOM:** (Optional) A captured transom that utilizes either aluminum pressure plates in conjunction with glazing gaskets and steel screws or with structural silicone installed in accordance with the manufacturer's instructions may be installed below the curtainwall insulation (Item 2F) and may be formed of any material that complies with applicable building code and regulatory requirements. Install in accordance with the exterior curtain wall assembly manufacturer's instructions and the design specifications.

O. **ARCHITECTURAL COVER:** (Optional, Not Shown) An architectural cover that hides the perimeter joint protection (Item 3) may be installed in accordance with the exterior curtain wall assembly manufacturer's instructions and the design specifications.

P. **WINDLOAD ANCHOR:** (Optional) A windload anchor may be installed on the underside of the curtainwall insulation (Item 2F) and may be formed of any material that complies with applicable building code and regulatory requirements. Install in accordance with the exterior curtain wall assembly manufacturer's instructions and the design specifications.

Q. **VISION PANELS:** Vision panels are to be in compliance with exterior curtain wall assembly (Item 2) design specifications. Glazing panels may be secured in position with aluminum pressure plates in conjunction with glazing gaskets and steel screws or with structural silicone installed in



accordance with the manufacturer's instructions.

3. PERIMETER JOINT PROTECTION: The perimeter joint (linear opening) is not to exceed a 3-3/8 in. (86 mm) nominal joint width (joint width at installation). The perimeter joint treatment shall incorporate the following construction features:

A. **CERTIFIED MANUFACTURER:** Thermafiber

CERTIFIED PRODUCT: Mineral Wool

CERTIFIED MODEL: Safing

PACKING MATERIAL: Install minimum 4 in. (102 mm) depth, 4 pcf (64 kg/m³) density, mineral wool batt insulation installed with the fibers running parallel to the slab edge and curtain wall. Divide the nominal joint width by 0.75 to provide the width of mineral wool to be cut and installed to produce the required minimum 25% compression in the nominal joint width. Install the batt insulation into the perimeter joint flush with the top surface of the concrete floor assembly (Item 1). Splices (butt joints) in the lengths of mineral wool batt insulation are to be tightly compressed together. In locations around every mounting attachment (Item 2A) increase the depth of mineral wool to a minimum 8 in. (203 mm) to provide a minimum 2 in. (51 mm) protective layer under the mounting attachment. This increased depth is to be applied for a minimum horizontal distance of 2 in. (51 mm) on both sides of the mounting attachment.

B. **CERTIFIED MANUFACTURER:** Specified Technologies, Inc.

CERTIFIED PRODUCT: Joint Sealant Spray

CERTIFIED MODEL: SpecSeal® AS200 Elastomeric Firestop Spray (AS205 series), SpecSeal® FastTack® Firestop Spray

FILL, VOID, OR CAVITY MATERIAL: Apply a minimum wet film thickness of 1/8 in. over the packing material (Item 3A) and overlap the liquid spray material a minimum 1/2 in. onto the interior surface of the adjacent curtain wall assembly (Item 2) and concrete floor slab assembly (Item 1). If the spraying process is stopped and the applied liquid spray material cures to an elastomeric film before process is restarted, then overlap the edge of the cured spray material at least 1/8 in. with the liquid spray material.

C. **CERTIFIED MANUFACTURER:** Thermafiber

CERTIFIED PRODUCT: Mineral Wool

CERTIFIED MODEL: Safing

COVER MATERIAL: (Not Shown) For any anchor system (Item 1A) that is exposed on both the underside and top side of the perimeter joint protection (Item 3), install a minimum 1/2-in. (13 mm) thick layer of packing material over the mounting attachment for the width of the joint. The cover requires no attachment and is to extend a minimum 2 in. (51 mm) on each side of the exposed mounting attachment.



Consult the listing report on the Directory of Building Products (<https://bpdirectory.intertek.com>) for the edition of the standard(s) evaluated.

Compliance of the assembly described in this Design Listing with the referenced standard relies on verification that the assembly constructed in the field is consistent with that described herein. Intertek certified products may be verified by the approved Intertek label; other products must be verified by the Authority Having Jurisdiction as meeting the specifications stated herein.