Specified Technologies, Inc.
Design No. STI/BPF 120-48
Perimeter Fire Barrier System – Curtain Wall Assembly
SpecSeal® AS200 Series Elastomeric Spray
SpecSeal® FastTack® Firestop Spray
ASTM E2307, CAN/ULC-S115
Rating: F-Rating – 2 hr
Movement Type = Class IV
Rated for ± 5 % Vertical Movement @ 25% Compression (Item 3A)

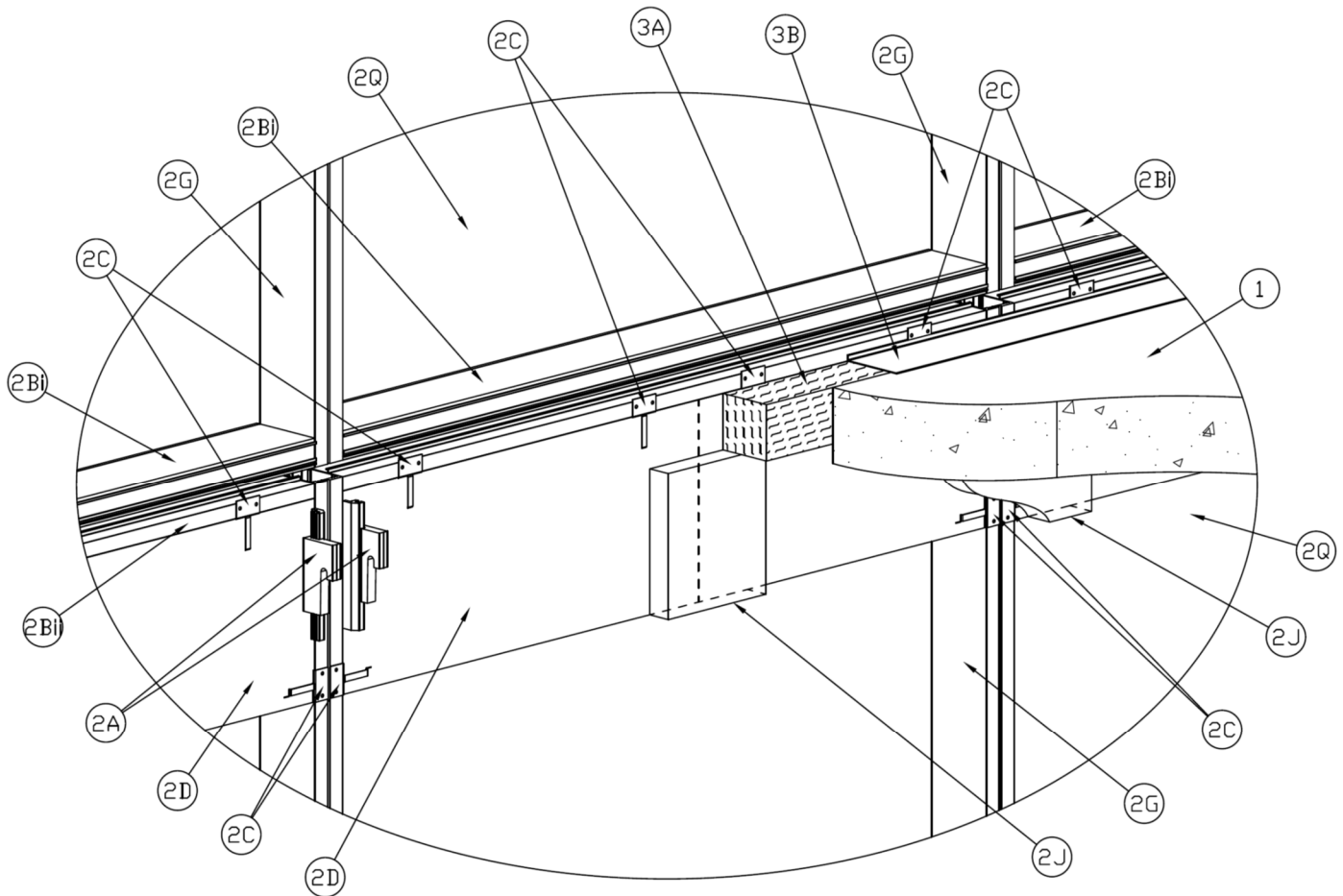

Figure 1 - Isometric with Interior Vertical Mullion Detail

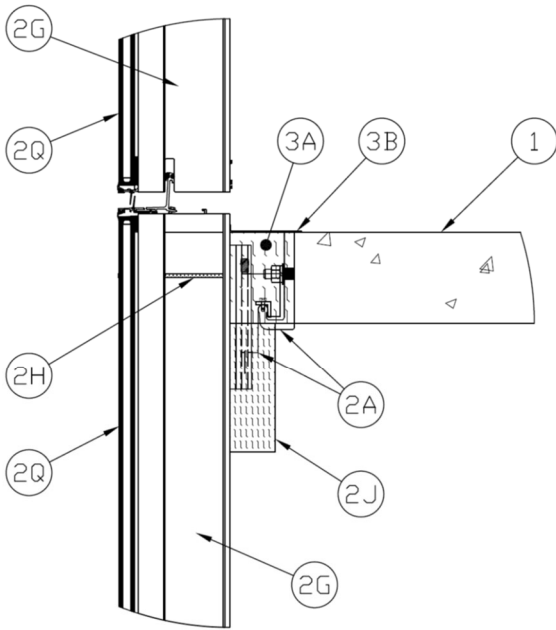

Figure 2 - Base Detail at Anchors (Face of Slab)

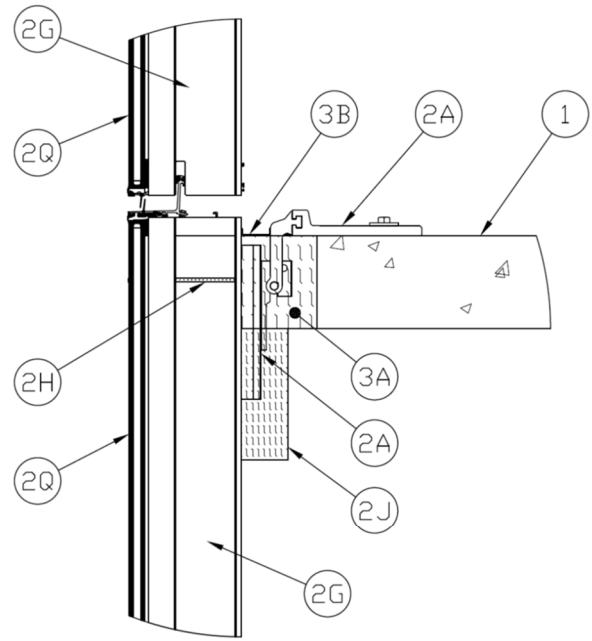

Figure 3 - Base Detail at Anchors (Top of Slab)

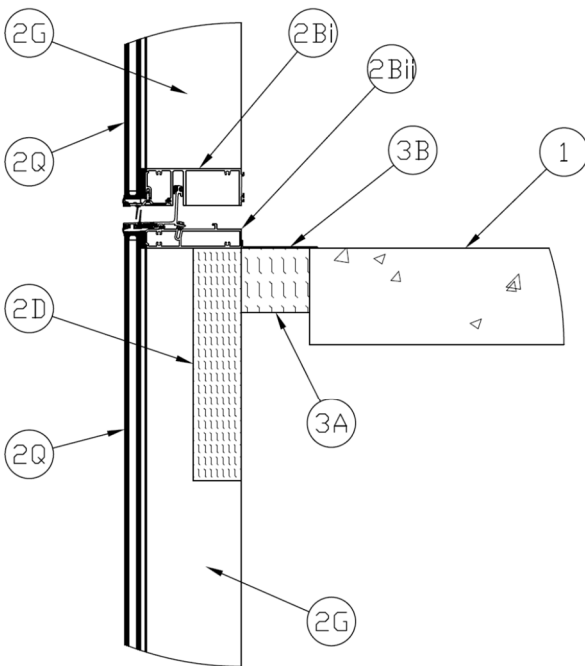

Figure 4 - Base Detail Between Anchors

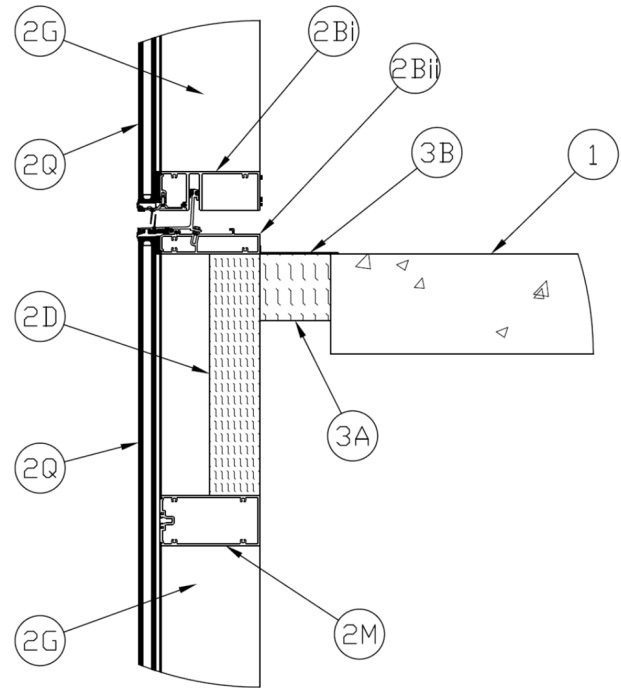

Figure 5 - Base Detail Between Anchors (Kiss Transom)

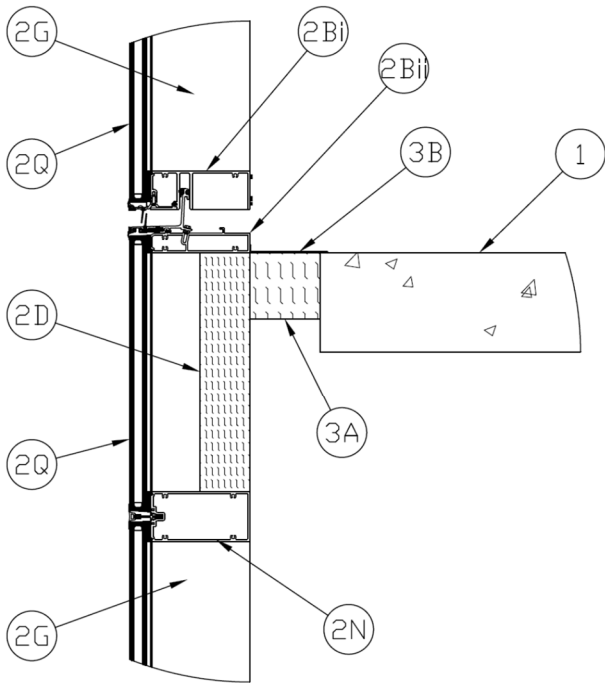

Figure 6 - Base Detail Between Anchors (Captured Transom)

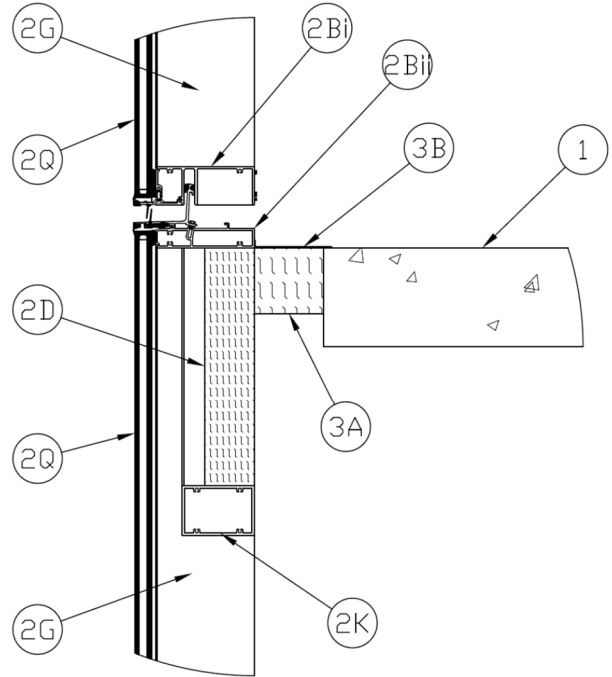

Figure 7 - Base Detail Shadow Box

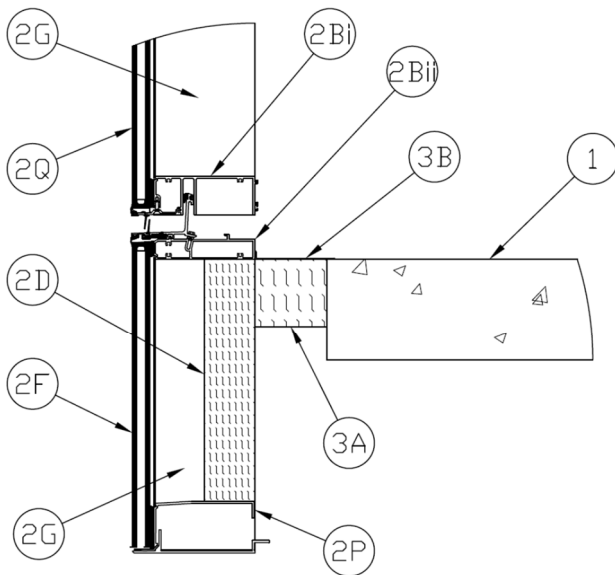

Figure 8 - Windload Anchor Configuration



1. **CONCRETE FLOOR ASSEMBLY:** Minimum one-hour rated concrete floor assembly made from either lightweight or normal weight concrete with a density of 100-150 pcf, with a minimum thickness of 6 in. (152 mm) at the joint face. F-rating will be determined by the rating of the floor system up to a maximum of two-hour F-rating.

A. **STEEL EMBED:** As required when face-mounted anchors (Item 2Ai) are used as a mounting attachment, install minimum 1-3/8 in. × 2 in. (35 mm × 51 mm) steel tube embeds with 7/8 in. (22 mm) slots on the front face are to be laterally centered at each mullion location and cast in place flush with the edge of the concrete floor assembly in accordance with the anchor manufacturer's installation instructions.

2. **CURTAIN WALL ASSEMBLY:** Construct the exterior wall assembly in compliance with applicable building codes and regulatory requirements which shall incorporate the following features:

A. **MOUNTING ATTACHMENT:** The mounting attachments to the floor slab shall consist of one or both of the following methods:

i. **FACE MOUNTED ANCHOR:** Anchor consists of a one or two-piece, 1/2 in. (13 mm) thick, extruded aluminum faceplate with minimum 3/8 in. (9.5 mm) arms that form an "L" or "J" shape that engages with an aluminum crossbar support. The height of the anchor plate is nominally 9 in. (229 mm) and may be positioned vertically at any point on the edge of the floor assembly (Item 1) from flush with the top of the concrete floor assembly and may extend up to 3 in. below the concrete

floor assembly. The mullion anchor plates are secured to the sides of the mullion, with interior edges flush with the interior face of the mullion, with steel bolts and nuts that engage with hardware internal to the mullion. The mullion anchor hook plate consists of a nominal 2-1/2 in. (64 mm) wide × 10 in. (254 mm) tall × 3/8 in. (9.5 mm) thick extruded aluminum plate with fist sliders that sit proud of the mullion face within the safig slot of the perimeter joint protection (Item 3). The fist sliders receive minimum 1/2 in. (13 mm) diameter jack bolts that are used to adjust the vertical position of the wall. The fist sliders may extend above the floor and up to 4-1/2 in. (114 mm) below the floor assembly (Item 1). The fist sliders may extend up to 4-1/2 in. (114 mm) below the packing material (Item 3A). The crossbar may extend up to 3-1/2 in. (89 mm) below the floor assembly.

ii. **TOP MOUNTED ANCHOR:** Anchor consists of a top-mounted extruded aluminum anchor plate measuring minimum 1/2 in. (13 mm) in thickness. Secure to the top of the concrete floor assembly (Item 1) in accordance with the curtain wall manufacturer's instructions with two 1/2-in. (13 mm) diameter steel masonry anchors with washer plates as supplied by the anchor manufacturer. Mounting bracket may be attached to the top of the floor or embedded within a cast anchor slot as required. Top mounted plate connects with mullion anchor plates measuring minimum 3/8 in. (10 mm) having a vertical height of minimum 10 in. (254 mm) and a width of 3 in. (76 mm)



positioned so that 2 in. (51 mm) overlap onto the mullion on both sides of the mullion. The top mounted anchor plate engages with fist sliders on the side mullion anchor plates. The fist sliders may extend from above the floor to a minimum 1 in. (25 mm) above the bottom of the packing material (Item 3A).

B. STACK JOINT: The true stack joint consists of the Upper Transom (Item 2Bi) and the Anchor Head (Item 2Bii). The stack joint is adjustable, and the height of the stack joint may range from 4.8 in. (122 mm) in its fully closed position, to 6 in. (152 mm) in its fully open position. The maximum gap between the Upper Transom (Item 2Bi) and the Anchor Head (Item 2Bii) is 1-1/4 in. (32 mm). The sill height between the top of the floor and the underside of the stack joint may range from 0 in. to 12 in. (0 mm to 305 mm). See item 2G for vertical mullion spacing restrictions dependent on sill height ranges.

i. **UPPER TRANSOM:** The upper transom consists of a nominal 0.10 in. (2.5 mm) extruded aluminum section with an exterior wet chamber and interior profile that receives the “chicken head” from the anchor head extrusion (Item 2Bii), forming the stack joint. The top of the upper transom is positioned directly above the anchor head transom (Item 2Bii). The front-to-back width of the upper transom is minimum 6-1/8 in. (156 mm).

ii. **ANCHOR HEAD:** The anchor head consists of nominal 0.10 in. (2.5 mm) thick extruded aluminum having a complex shape including a “chicken head” that mates with receiving

channels on the upper transom (Item 2Bi). The height of the anchor head extrusion, from the bottom to the top of the “chicken head,” is nominally 4-3/16 in. (106 mm) and the width from front to back is minimum 6-1/8 in. (156 mm). The anchor head contains a wet chamber on the exterior side and on the interior may be constructed with a single or double “chicken head” per the design of the manufacturer.

iii. **CERTIFIED MANUFACTURER:**
Thermafiber

CERTIFIED PRODUCT: Mineral Wool

CERTIFIED MODEL: Safing

TROUGH INSULATION: Inside the anchor head trough between the chicken heads, install minimum 4 pcf (64 kg/m³) density mineral wool cut to a length of 6 in. (152 mm) and 3 in. (76 mm) deep. The mineral wool is to be centered over the joint between adjacent panels and extend a minimum of 3 in. (76 mm) on each side of the joint. The insulation is to be friction-fitted into place between the chicken heads and installed uncompressed to the full height of the anchor head cavity. The insulation will receive compression from the upper transom when upper panels are installed.

C. CURTAINWALL INSULATION RETAINING SYSTEM: A steel retaining clip system is used to secure the curtainwall insulation (Item 2D) to the spandrel. The clip system may consist of any combination of the following styles.



- i. **U-SHAPED STEEL BRACKET** (Not shown): When Specified Technologies, Inc. SpecSeal® QuickClip™ U-shaped brackets are used on the mullion below the floor assembly, install at least one bracket, made from 20 GA steel, on each mullion for sill heights up to 5-1/2 in. (140 mm) and at least two brackets on each mullion for sill heights over 5-1/2 in. (140mm) with one above and one below the floor. U-shaped brackets serve to support curtainwall insulation (Item 2D) in spandrels on both sides of the mullion simultaneously. U-shaped brackets can be used in tandem with Z-shaped brackets (Item 2Cii). U-shaped brackets are secured to the interior face of mullions (Item 2G) and are used to secure spandrel insulation within framed openings by means of a staple-shaped fastener that penetrates the insulation and interlocks with the bracket. A single 1/2 in. (13 mm) No. 10 self-tapping screw is required to secure the bracket on the interior side of the mullion. The first bracket, below the floor, is to be located a maximum of 9-1/4 in. (235 mm) under the floor. Any additional brackets required below the first bracket are to be spaced no more than 20-3/4 in. (527 mm) on-center (oc). When U-shaped brackets are used above the floor, they are to be located on the mullion a maximum 2 in. (51 mm) above the floor. U-shaped brackets cannot be used on the stack joint transom (Item 2B). Brackets are to be installed onto mullions per the manufacturer's instructions.
- ii. **Z-SHAPED STEEL BRACKET** (Not Shown): When Specified Technologies, Inc. SpecSeal® QuickClip™ Z-shaped

brackets are used on the mullion below the floor assembly, install at least two brackets, made from 20 GA steel, on each mullion, and on both left and right sides, as necessary for sill heights up to 5-1/2 in. (140 mm) and at least four brackets on each mullion for sill heights over 5-1/2 in. (140 mm) with two above and two below the floor. Z-shaped brackets can be used in tandem with U-shaped brackets (Item 2Ci). Z-shaped brackets are secured to the interior face of mullions (Item 2G) and are used to secure spandrel insulation within framed openings by means of a staple-shaped fastener that penetrates the insulation and interlocks with the bracket. A single 1/2 in. (13 mm) No. 10 self-tapping screw is required to secure the bracket on the interior side of the mullion. The first bracket, below the floor, is to be located a maximum of 9-1/4 in. (235 mm) under the floor. Any additional brackets required below the first bracket are to be spaced no more than 20-3/4 in. (527 mm) oc. When Z-shaped brackets are used on the mullion above the floor, they are to be located on the mullion a maximum 2 in. (51 mm) above the floor. When Z-shaped clips are used on the stack joint transom, they are to be spaced no more than 6 in. from the mullion, no more than 6 in. on both sides of a vertical seam of the curtainwall insulation (Item 2D), and no more than 23 in. (584 mm) oc. For any mullion span larger than 37-1/4 in. (946 mm), install sufficient brackets to maintain the maximum allowed spacing requirement.

- iii. **L-SHAPED STEEL BRACKET** (Not Shown): When Specified Technologies, Inc.



SpecSeal® QuickClip™ L-shaped brackets are used on the mullion below the floor assembly, install at least two brackets, made from 20 GA steel, on each mullion, and on both left and right sides, as necessary for sill heights up to 5-1/2 in. (140 mm) and at least four brackets on each mullion for sill heights over 5-1/2 in. (140mm) with two above and two below the floor. L-shaped brackets can be used in tandem with Z-shaped brackets (Item 2Cii). L-shaped brackets are secured to the interior face of mullions (Item 2G) and are used to secure spandrel insulation within framed openings by means of a staple-shaped fastener that penetrates the insulation and interlocks with the bracket. A single 1/2 in. (13 mm) No. 10 self-tapping screw is required to secure the bracket on the side face of the mullion. The first bracket, below the floor, is to be located a maximum of 9-1/4 in. (235 mm) under the floor. Any additional brackets required below the first bracket are to be spaced no more than 20-3/4 in. (527 mm) oc. When L-shaped brackets are used on the mullion above the floor, they are to be located on the mullion a maximum 2 in. (51 mm) above the floor. When L-shaped clips are used on the stack joint transom, they are to be spaced no more than 6 in. from the mullion, no more than 6 in. on both sides of a vertical seam of the curtainwall insulation (Item 2D), and no more than 23 in. (584 mm) oc. For any mullion span larger than 37-1/4 in. (946 mm), install sufficient brackets to maintain the maximum allowed spacing requirement.

D. CERTIFIED MANUFACTURER: Thermafiber

CERTIFIED PRODUCT: Mineral Wool

CERTIFIED MODEL: Firespan 90

CURTAIN WALL INSULATION: Install minimum 3 in. (76 mm) thick 8 pcf (128 kg/m³) density mineral wool with foil-scrim facing on the interior side into the spandrel, flush with the interior side of the mullions. Insulation batt is to be butted up to the underside of the anchor head transom and friction fit between the mullions with a minimum 1/8 in. (3 mm) over-cut on the spandrel width. The insulation is to extend from the underside of the anchor head transom downward in the spandrel cavity a minimum 20-3/4 in. (527 mm). The curtainwall insulation is to be secured with the Curtainwall Insulation Retention System (Item 2C). The curtainwall insulation is not required to terminate at a lower transom. Space below the curtainwall insulation between the bottom of the insulation and the next lower transom may be left void or filled with alternative insulative materials (Item 2E). A maximum of one vertical seam is allowed in the spandrel. When a vertical seam is required, the seam is to be bridged with a mullion cover (Item 2J) below the floor.

E. ALTERNATIVE INSULATIVE MATERIALS: In any space that exists below the curtainwall insulation (Item 2D), where insulation is required for energy conservation requirements or other purposes, the space may be filled with any material that complies with applicable building code and regulatory requirements.

F. EXTERIOR SPANDREL CLADDING: (Optional) Install glazing or an exterior



cladding system that complies with applicable building code and regulatory requirements. Install in accordance with the exterior curtain wall assembly manufacturer's instructions and the design specifications. Glazing panels or other specified cladding may be secured in position with aluminum pressure plates in conjunction with glazing gaskets and steel screws or with structural silicone installed in accordance with the manufacturer's instructions.

- G. **VERTICAL MULLIONS:** Vertical mullions are constructed of nominal 1/8 in. (3 mm) extruded aluminum. Mullions can be constructed as solid members, or as joining members that are split vertically. Mullions are designed with a wet chamber on the exterior side and a dry chamber on the interior side. Mullions have a minimum depth of 6 in. (152 mm) and a minimum width of 3-1/2 in. (89 mm). Minimum spacing of the mullions is 18 in. (45.7 cm) oc. For sill heights (See Item 2B) up to 5-1/2 in. (140 mm), maximum spacing of the mullions is 81-1/2 in. (207 cm) oc and the horizontal span between mullions may not exceed 78 in. (198 cm). For sill heights over 5-1/2 in. (140 mm) up to maximum 12 in. (305 mm) the maximum spacing of the mullions is 63-1/2 in. (161 cm) and the span between mullions may not exceed 60 in. (152 cm).
- H. **MULLION PLUG:** When a true stack joint is present, a Specified Technologies, Inc. SpecSeal® Mullion Plug must be applied within the dry cavity of the mullion, with the top edge of the mullion foam flush with the top of the floor and with the intumescent side of the plug facing downward. Plug shall be cut to match the profile of the mullion

cavity it is placed in and sized slightly larger than the cavity as to fully fill the space and form a friction fit

- I. **CERTIFIED MANUFACTURER:** Thermafiber

CERTIFIED PRODUCT: Mineral Wool

CERTIFIED MODEL: Firespan 90

MULLION FILLER: (Not Shown) Any dry cavity space that exists above the mullion plug (Item 2H), must be filled with 4 pcf (64 kg/m³) density mineral wool, loosely packed into the cavity space at the same vertical level of the mullion plug.

- J. **CERTIFIED MANUFACTURER:** Thermafiber

CERTIFIED PRODUCT: Mineral Wool

CERTIFIED MODEL: Firespan 90

MULLION COVERS: Install minimum 2 in. (51 mm) thick 8 pcf (128 kg/m³) density mineral wool with foil-scrim facing on the interior side over the vertical mullion (Item 2G) or any vertical seam in the curtain wall insulation (Item 2D) on the interior side of the wall below the concrete floor assembly (Item 1). The mullion cover is to be centered on the mullion over the seam and shall extend a minimum 3-1/2 in. (89 mm) on each side of the mullion or seam and vertically extend from below the packing material (Item 3A) to the bottom of the curtain wall insulations (Item 2D). Secure the mullion cover to the curtainwall insulation with four, steel spiral anchors that extend a minimum 1 in. (25 mm) into the curtainwall insulation and are to be located in the corners of the covers, a minimum of 1 in. from the edges. Aluminum



foil tape may be used to seal the mullion cover edges to the curtainwall insulation but is not required.

- K. **SHADOW BOX:** (Optional) A shadow box installed on the exterior side of the curtainwall insulation (Item 2D) may be formed of any material that complies with applicable building code and regulatory requirements. Install in accordance with the exterior curtain wall assembly manufacturer's instructions and the design specifications
- L. **INTERMEDIATE TRANSOM:** (Optional) An intermediate transom may be installed on the underside of the curtainwall insulation (Item 2D) and may be formed of any material that complies with applicable building code and regulatory requirements. Install in accordance with the exterior curtain wall assembly manufacturer's instructions and the design specifications.
- M. **CONTINUOUS GLAZING FRAME (KISS TRANSOM):** (Optional) A continuous glazing frame (Kiss Transom) may be installed below the curtainwall insulation (Item 2D) and may be formed of any material that complies with applicable building code and regulatory requirements. Install in accordance with the exterior curtain wall assembly manufacturer's instructions and the design specifications.
- N. **CAPTURED TRANSOM:** (Optional) A captured transom that utilizes either aluminum pressure plates in conjunction with glazing gaskets and steel screws or with structural silicone installed in accordance with the manufacturer's instructions may be installed below the curtainwall insulation (Item 2D) and may be

formed of any material that complies with applicable building code and regulatory requirements. Install in accordance with the exterior curtain wall assembly manufacturer's instructions and the design specifications.

- O. **ARCHITECTURAL COVER:** (Optional, Not Shown) An architectural cover that hides the perimeter joint protection (Item 3) may be installed in accordance with the exterior curtain wall assembly manufacturer's instructions and the design specifications.
 - P. **WINDLOAD ANCHOR:** (Optional) A windload anchor may be installed on the underside of the curtainwall insulation (Item 2D) and may be formed of any material that complies with applicable building code and regulatory requirements. Install in accordance with the exterior curtain wall assembly manufacturer's instructions and the design specifications.
 - Q. **VISION PANELS:** Vision panels are to be in compliance with exterior curtain wall assembly (Item 2) design specifications. Glazing panels may be secured in position with aluminum pressure plates in conjunction with glazing gaskets and steel screws or with structural silicone installed in accordance with the manufacturer's instructions.
3. **PERIMETER JOINT PROTECTION:** The perimeter joint (linear opening) is not to exceed a 3-3/8 in. (86 mm) nominal joint width (joint width at installation). The perimeter joint treatment shall incorporate the following construction features:
- A. **CERTIFIED MANUFACTURER:** Thermafiber
CERTIFIED PRODUCT: Mineral Wool



CERTIFIED MODEL: Safing

PACKING MATERIAL: Install minimum 4 in. (102 mm) depth, 4 pcf (64 kg/m³) density, mineral wool batt insulation installed with the fibers running parallel to the slab edge and curtain wall. Divide the nominal joint width by 0.75 to provide the width of mineral wool to be cut and installed to produce the required minimum 25% compression in the nominal joint width. Install the batt insulation into the perimeter joint flush with the top surface of the concrete floor assembly (Item 1). Splices (butt joints) in the lengths of mineral wool batt insulation are to be tightly compressed together. In locations around every mounting attachment (Item 2A) increase the depth of mineral wool to a minimum 8 in. (203 mm) to provide a minimum 2 in. (51 mm) protective layer under the mounting attachment. This increased depth is to be applied for a minimum horizontal distance of 2 in. (51 mm) on both sides of the mounting attachment. For any exposed surface of the mounting attachment flush with the top of the joint, install a minimum 3/4 in. (19 mm) layer of packing material over the mounting attachment for the width of the joint. The cover requires no attachment and is to extend a minimum of 2 in. (51 mm) on each side of the exposed mounting attachment.

- B. **CERTIFIED MANUFACTURER:** Specified Technologies, Inc.

CERTIFIED PRODUCT: Joint Sealant Spray

CERTIFIED MODEL: SpecSeal® AS200 Elastomeric Firestop Spray (AS205 series), SpecSeal® FastTack® Firestop Spray

FILL, VOID, OR CAVITY MATERIAL: Apply a minimum wet film thickness of 1/8 in. over the packing material (Item 3A) and overlap the liquid spray material a minimum 1/2 in. onto the interior surface of the adjacent curtain wall assembly (Item 2) and concrete floor slab assembly (Item 1). If the spraying process is stopped and the applied liquid spray material cures to an elastomeric film before process is restarted, then overlap the edge of the cured spray material at least 1/8 in. with the liquid spray material.

- C. **CERTIFIED MANUFACTURER:** Thermafiber

CERTIFIED PRODUCT: Mineral Wool

CERTIFIED MODEL: Safing

COVER MATERIAL: (Not Shown) For any anchor system (Item 2A) that is exposed on both the underside and top side of the perimeter joint protection (Item 3), install a minimum 1/2-in. (13 mm) thick layer of packing material over the mounting attachment for the width of the joint. The cover requires no attachment and is to extend a minimum 2 in. (51 mm) on each side of the exposed mounting attachment.



Consult the listing report on the Directory of Building Products (<https://bpdirectory.intertek.com>) for the edition of the standard(s) evaluated.

Compliance of the assembly described in this Design Listing with the referenced standard relies on verification that the assembly constructed in the field is consistent with that described herein. Intertek certified products may be verified by the approved Intertek label; other products must be verified by the Authority Having Jurisdiction as meeting the specifications stated herein.