

Specified Technologies, Inc.

Design No. STI/BPF 150-02

Perimeter Fire Barrier System – Curtain Wall Assembly

SpecSeal® AS200 Series Elastomeric Spray, SpecSeal® Fast Tack® Firestop Spray

EN 1364-4 (2014)

Rating: Integrity Rating – 2-1/2 Hour

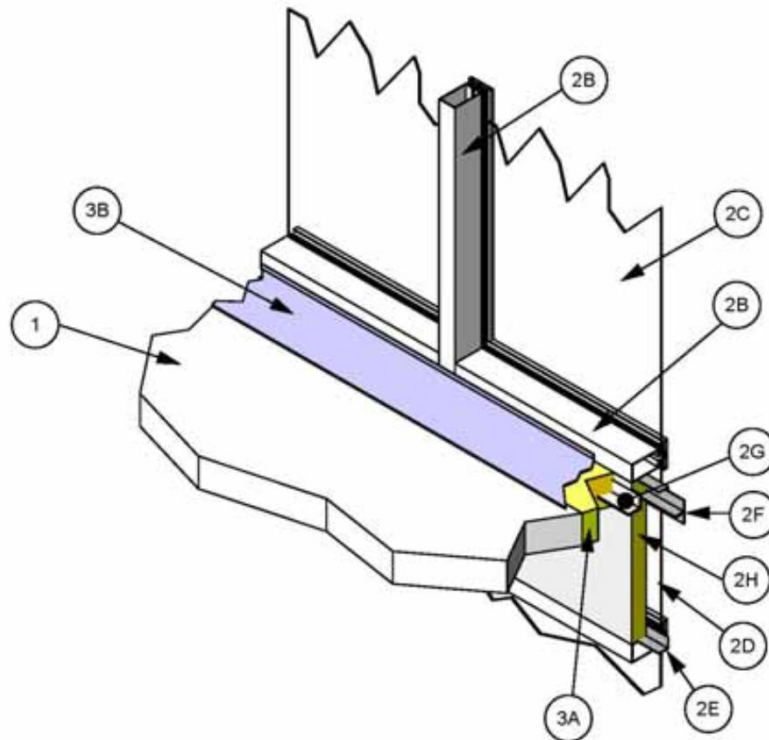

1. **CONCRETE FLOOR ASSEMBLY:** Two hour rated concrete floor assembly made from either lightweight or normal weight concrete with a density of 100-150 pcf, with a min. thickness of 4 in. at the joint face. Overall slab thickness may vary to accommodate various blockout depths (longitudinal recesses) formed in the concrete, to house the architectural cover plate. The blockout width may also vary without restriction.

2. **CURTAIN WALL ASSEMBLY:** The curtain wall assembly shall incorporate the following construction features:

- A. **MOUNTING ATTACHMENT – (Not Shown)**
The mounting attachments to the floor slab shall be connected to the joint face of the floor slab, in accordance with the curtain wall manufacturer’s instructions. Attachments are to be secured to each mullion in the perimeter joint protection region at a max. spacing of 60 in. on center (oc).
- B. **ALUMINUM FRAMING –** Size rectangular aluminum tubing mullions and transoms, according to the curtain wall system manufacturer’s guidelines. Min. overall



dimensions of the extruded framing sections are 0.100 in. thick aluminum with a min. 3-3/4 in. depth and a min. of 2-1/2 in. width. Mullion and transom covers are added to the external side of the framing, giving the framing system a total depth of nominal 5-1/4 in. Mullions are to be spaced a min. 60 in. oc and spandrel transoms are to be spaced a min. 10 in. oc. For the spandrel region, the lower transom must be placed a min. of 5-1/2 in. below the concrete floor (as measured from the underside of the floor to the top side of the transom) and the upper transom (as measured from the top surface of the floor to the underside of the transom) may be located flush with the top surface of the floor, while maintaining the min. 10 in. spandrel height.

- C. VISION GLASS PANELS – Size and install panels to curtain wall framing according to the curtain wall system manufacturer's guidelines. Use min. 1/4 in. thick, clear heat-strengthened (HS) glass or tempered glass with a max. width and height less than the aluminum framing oc spacing, which allows the glass to be secured between the notched shoulder of the aluminum framing and pressure bar. Panels are secured with a thermal break (rubber extrusion), pressure bar (aluminum extrusion), min. 1/4-20 x 5/8-in.-long screws, and a snap face (aluminum extrusion).
- D. SPANDREL PANELS – Size and install panels to curtain wall framing according to the curtain wall system manufacturer's guidelines. Use min. 1/4 in. thick, clear heat-strengthened (HS) glass, tempered glass or solid aluminum panels with a max. width and height less than the aluminum framing oc spacing, which allows the glass

or aluminum panels to be secured between the notched shoulder of the aluminum framing and pressure bar. Panels are secured with a thermal break (rubber extrusion), pressure bar (aluminum extrusion), min. 1/4-20 x 5/8-in. long screws, and a snap face (aluminum extrusion).

- E. PERIMETER SPANDREL ANGLES – Min. 20 GA, 1-1/2 in. x 1-1/2 in. galvanized steel angle is placed around the entire inside perimeter of the spandrel framing and is secured to the aluminum wall framing (Item 2B) with 3/4 in. long hex-head, self-drilling sheet metal screws spaced max. 8 in. oc.
- F. REINFORCING ANGLE – At the horizontal butt joints of the curtain wall insulation (Item 2H) in the spandrel area, place two 1-1/2 x 1-1/2 in., 20 GA steel angles back-to-back to form a "T". Locate the "T" reinforcing angle at the horizontal centerline of the perimeter joint protection and secure the "T" to the perimeter spandrel angles (Item 2E) with 3/4 in. long hex-head, self-drilling sheet metal screws spaced max. 8 in. oc.
- G. PERIMETER FIRE BARRIER REINFORCEMENT ANGLE – Constructed of min. 20 GA, 1-1/2 x 1-1/2 in. steel angle. The horizontal leg of the angle is fully embedded into the packing material (Item 3A) at the centerline of the perimeter fire barrier, and the vertical leg is secured to the interior side of every vertical aluminum wall framing (Item 2B) member with at least two min. 1/2 in. long, #10 sheet metal screws, spaced max. 1 in. oc. The angle is to be continuous along the length of the perimeter fire barrier. Where joints are required, overlap the



angle 12 in. and secure the adjoining angle with at least three min. 1/2 in. long #10 sheet metal screws spaced max. 4 in. oc., placed in both the vertical and horizontal legs of the angle.

H. **CERTIFIED MANUFACTURER:** Rockwool

CERTIFIED PRODUCT: Mineral Wool

CERTIFIED MODEL: CurtainRock 80

CURTAIN WALL INSULATION – A nominal 2 in. thick, 8 pcf density mineral wool batt insulation, faced on one side with aluminum foil scrim (vapor retarder) which faces the room interior, is installed to fill all cavities of the spandrel region between the framing. The batt is to be fitted tightly to the framing with the perimeter spandrel angle (Item 2E) and impaling screws (Item 2I). Seal all meeting edges of insulation with nominal 4 in. wide, pressure-sensitive aluminum foil faced tape, centered over the junction so that approximately 2 in. of tape covers each edge of the adjacent insulation. Place a horizontal seam at the centerline of the perimeter joint protection and reinforce with angle (Item 2F). Install the 24 in. wide batts without vertical seams, spanning the full length between the vertical curtain wall framing members. The interior face of the batt insulation is, if required, compressed flush with the interior face of the curtain wall framing creating a min. 1 in. air space between the insulation and the glass.

- I. **IMPALING SCREWS – (Not Shown)** Attach curtain wall insulation to the perimeter spandrel angle (Item 2E) with min. No. 8 bugle-head self-drilling screws, with a 1-1/2 in. diameter galvanized speed clip spaced max. 8 in. oc at the centerline of the flange.

Screws should be sized in accordance with the curtain wall insulation thickness, to maintain a firm attachment to the perimeter spandrel angle. Screws shall be installed so that the interior face of the curtain wall insulation is flush with the interior face of the framing.

J. **CERTIFIED MANUFACTURER:** Rockwool

CERTIFIED PRODUCT: Mineral Wool

CERTIFIED MODEL: CurtainRock 80

FRAMING (MULLION) COVERS – (Not Shown) Nominal 8 pcf mineral wool batt insulation, faced on one side with aluminum foil scrim (vapor retarder) which faces the room interior. Framing covers are below the perimeter joint treatment and are nominal 2 in. thick, 7 in. wide, and 5 in. tall. Center framing covers over each vertical framing member and secure to the member with #8 bugle-head self-drilling screws, with a 1-1/2 in. diameter galvanized speed clip spaced a min. 1 in. from each edge. Encapsulate the framing covers with nominal 4 in. wide, pressure-sensitive aluminum foil-faced tape. Overlap the tape approximately 2 in. onto the adjacent aluminum framing. Framing covers do not pass through the perimeter joint treatment. They are butted to the bottom surface of the perimeter joint treatment.

3. **PERIMETER JOINT PROTECTION:** The perimeter joint (linear opening) is not to exceed a nominal 8 in. joint width (joint width at installation). The perimeter joint treatment shall incorporate the following construction features:

A. **CERTIFIED MANUFACTURER:** Rockwool



CERTIFIED PRODUCT: Mineral Wool

CERTIFIED MODEL: Roxul SAFE

PACKING MATERIAL – Install min. 4 in. thick, 4 pcf density, mineral wool batt insulation installed with the fibers running parallel to the slab edge and curtain wall. After the perimeter fire barrier reinforcement angle (Item 2G) is installed, compress the packing material 33% by volume in the nominal joint width. Compress the batt insulation into the perimeter joint flush with the top surface of the concrete floor slab (Item 1) and its mid-depth is compressed against the interior surface of the curtain wall insulation (Item 2H) which is supported by the 20 GA steel reinforcing angle (Item 2F). Splices (butt joints) in the lengths of mineral wool batt insulation are to be tightly compressed together.

B. **CERTIFIED MANUFACTURER:** Specified Technologies Inc.

CERTIFIED PRODUCT: Joint Sealant Spray

CERTIFIED MODEL: SpecSeal® AS Elastomeric Firestop Spray (AS200 Series), SpecSeal® Fast Tack® Firestop Spray

FILL, VOID, OR CAVITY MATERIAL – Apply a min. wet film thickness of 1/8 in. over the packing material (Item 3A) and overlap the liquid spray material a min. 1/2 in. onto the adjacent curtain wall framing (Item 2B) and concrete floor slab assembly (Item 1). If the spraying process is stopped and the applied liquid spray material cures to an elastomeric film before process is restarted, then overlap the edge of the cured spray material at least 1/8 in. with the liquid spray material.

Consult the listing report on the Directory of Building Products (<https://bpdirectory.intertek.com>) for the edition of the standard(s) evaluated.

Compliance of the assembly described in this Design Listing with the referenced standard relies on verification that the assembly constructed in the field is consistent with that described herein. Intertek certified products may be verified by the approved Intertek label; other products must be verified by the Authority Having Jurisdiction as meeting the specifications stated herein.