

Specified Technologies, Inc.
Design No. STI/BPF 60-03
Perimeter Fire Barrier System
SpecSeal® AS Elastomeric Spray
ASTM E2307, CAN/ULC-S115
Ratings: F-Rating – 1 Hour, T-Rating – 1/2 Hour
UL 2079 Air Leakage
L-Rating: <2 SCFM/LF
ASTM E1399 Class IV
Rated for ± 16.7% Horizontal Movement

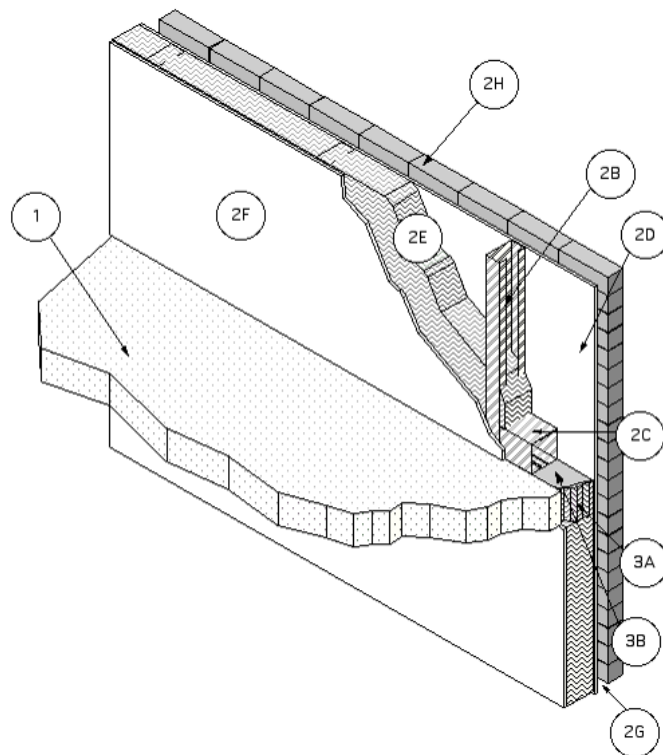

1. CONCRETE FLOOR ASSEMBLY: Two-hour rated concrete floor assembly made from either lightweight or normal weight concrete with a density of 100-150 pcf, with a min. thickness of 4-1/2-in. at the joint face. Overall slab thickness may vary to accommodate various blockout depths (longitudinal recesses) formed in the concrete, to house the architectural cover plate.

The blockout width may also vary without restriction.

2. CURTAIN WALL ASSEMBLY: The concrete curtain wall assembly shall incorporate the following construction features:

A. MOUNTING ATTACHMENT (Not shown)
Attachment of the curtain wall framing to



the structural framing shall be according to the curtain wall manufacturer's instructions. When required, the mounting attachments to the floor slab shall be connected to the joint face of the floor slab, according to the curtain wall manufacturer's instructions. Max. distance between mounting attachments shall be 10 feet.

- B. **Steel-Stud Framing:** Vertical framing members shall be a min. 3-5/8 in. by 1-5/8 in., 18 GA steel "C" studs. Attachment shall be according to the curtain wall system manufacturer's guidelines. Vertical framing shall not exceed a spacing of 48 in. o.c. If required, horizontal framing members shall be installed according to the curtain wall system manufacturer's guidelines.
- C. **Steel Box Beam:** Shall be made of two inward facing min. 3-5/8 in. by 1-5/8 in., 18 GA steel "C" studs seated in a min. 18 GA steel "U" channels (top and bottom) sized to span the distance between the two layers of gypsum wallboard.
- D. **Sandwiched Wall Surface:** Use a min. 1/2 in. thick, 48 in. wide by 96 in. long, Type X gypsum wallboard, placed over and secured to framing with 1 in. long Type S drywall screws 8 in. o.c. on the periphery and 12 in. o.c. in the field. Screw heads are covered with joint compound. Joints created between gypsum wallboard are taped and floated with joint compound.
- E. **Interior Curtain Wall Surface:** Use a min. 1/2 in. thick, 48 in. wide by 96 in. long, Type X gypsum wallboard, placed over and secured to framing with 1 in. long Type S drywall

screws 8 in. o.c. on the periphery and 12 in. o.c. in the field. Screw heads are covered with joint compound. Joints created between gypsum wallboard are taped and floated with joint compound.

- F. **Air Space:** A nominal 1-1/2-inch air space shall exist between the sandwiched wall surface (2D) and the exterior curtain wall surface (2H).
 - G. **Exterior Curtain Wall Surface:** Use a min. 4-inch thick brick veneer.
- 3. PERIMETER JOINT PROTECTION:** The perimeter joint (linear opening) shall not exceed a 6 in. nom. joint width (joint width at installation) and the perimeter joint treatment shall incorporate the following construction features:
- A. **CERTIFIED PRODUCT:** Rockwool Roxul Safe®

PACKING MATERIAL – Use a min. 4 in. thick, 4 pcf density, mineral wool batt insulation installed with the fibers running parallel to the slab edge and curtain wall. The packing material shall be compressed 50% in the nominal joint width. Compress the batt insulation into the perimeter joint such that the top surface of the batt insulation is flush with the top surface of the concrete floor slab. Splices (butt joints) in the lengths of mineral wool batt insulation are to be tightly compressed together. The packing material shall completely fill the recess of the min. 3-5/8 in. by 1-5/8 in., 18 GA steel "C" studs.

- B. **CERTIFIED PRODUCT:** Specified Technologies, Inc. SpecSeal® AS Elastomeric Spray (Cat No. AS205 and AS205R)

FILL, VOID, OR CAVITY MATERIAL – Liquid is to be spray applied to cover the exposed



surface of the mineral wool installed in the perimeter joint. Apply a min. wet film thickness of 1/8 in. and overlap the material a min. 1/2 in. onto the adjacent curtain wall assembly and concrete floor slab assembly. If the spraying process is stopped and the applied liquid cures to an elastomeric film before process is restarted, then overlap the edge of the cured material at least 1/8 in. with the spray.

subject to vertical shear movement. Standard Z-shaped clips are 20 GA galvanized steel with the following dimensions: 1 in. wide by 3 in. high with a 2 in. upper leg and 3 in. lower leg.

- C. Support Clips: (Not Shown) Support clips are optional but recommended for installations

Consult the listing report on the Directory of Building Products (<https://bpdirectory.intertek.com>) for the edition of the standard(s) evaluated.

Compliance of the assembly described in this Design Listing with the referenced standard relies on verification that the assembly constructed in the field is consistent with that described herein. Intertek certified products may be verified by the approved Intertek label; other products must be verified by the Authority Having Jurisdiction as meeting the specifications stated herein.